



User's Guide

Preparation



Part names	4
Control panel	5
Loading paper.....	6
Turning the machine on and off	12
About the display screens	13

Operation



Copy	14
Scan	16
Fax.....	22
Print	28
Using OfficeBridge	32
Replacing the consumables	38

Troubleshooting



Clearing document jams.....	40
Clearing paper jams	42
If an error occurs	45
Troubleshooting	46

Appendix

Regulatory information	48
How to read PDF manuals	50
Consumables and options	51
Index.....	52



bizhub 25e

For your safety





Please observe the safety precautions laid out in the separate booklet “Safety Information” to prevent electric shocks and injury to people or damage to property that may occur through misuse of this machine.

Also read “Cautions for using the machine” in the Administrator’s Guide.

How to read this manual

■ Symbols

In this manual, the following symbols are used with the items where important operational and safety information must be observed.

Symbols	Meanings
 WARNING	Describes warnings to protect yourself and others from serious or potentially fatal injury if you handle the machine incorrectly. For safe operation, please follow instructions carefully.
 CAUTION	Notes a caution to protect yourself and others from personal injury or damage to properties if you handle the machine incorrectly. For safe operation, please follow instructions carefully.
 IMPORTANT	Describes important conditions or restrictions you should carefully observe to avoid problems caused by incorrect operations.
 NOTE	Describes reference information and additional notes for operation.

■ Key descriptions

In this manual, the operating keys are described as follows:

< > : Keys on the control panel

For example, the start key → <Start>

[] : Buttons on the display and on the computer

For example, the “Setting” button → [Setting]

■ Descriptions for paper and documents

 symbol : This shows that paper should be set with the shorter side positioned at the top.

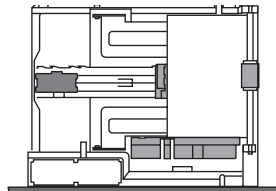

 symbol : This shows that the document should be set with the shorter side positioned at the top.

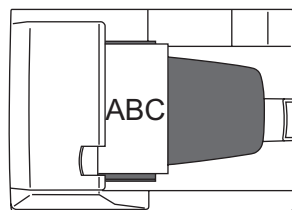
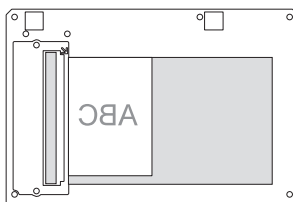

Welcome

Thank you for choosing the bizhub 25e.

Before using this machine, be sure to read the User's Guide (this booklet) thoroughly in order to ensure that you use the machine efficiently. After you have reviewed the manual, please keep it available to users at all times.

About the manuals

The following manuals have been created for this machine. The PDF manuals are located on the CD that came with your machine.

Booklets



User's Guide (This booklet)

This is a summary of the machine's basic functions and setup. Review this guide when using the machine for the first time or when performing a new function.



Safety information

This booklet contains instructions you should follow in order to use the machine safely. Please review this guide carefully before using this machine.

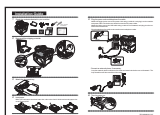

Installation Guide

This sheet contains instructions to assist you with the set-up of this machine.

PDF manuals located on the CD

Administrator's Guide

This guide covers the setup of soft-keys, default settings, machine usage management, network settings, and performing basic machine maintenance such as replacing the consumables and routine cleaning of the unit.

Copier Guide

This guide covers the copy capabilities of the machine.

Scanner and Fax Guide

This guide covers the scanning and faxing capabilities of the machine. This guide also covers how to handle communication errors that may occur.

Printer Guide

This guide covers the printing capabilities of the machine. This guide also covers the installation procedure for the printer drivers.

Message Board Guide

This guide covers the capabilities of the Message Board solution. Message Board enables you to access the machine using a web browser on your computer to view the machine status, set-up address books and machine settings, create users and more.

Powerful document solution
using the

bizhub 25e

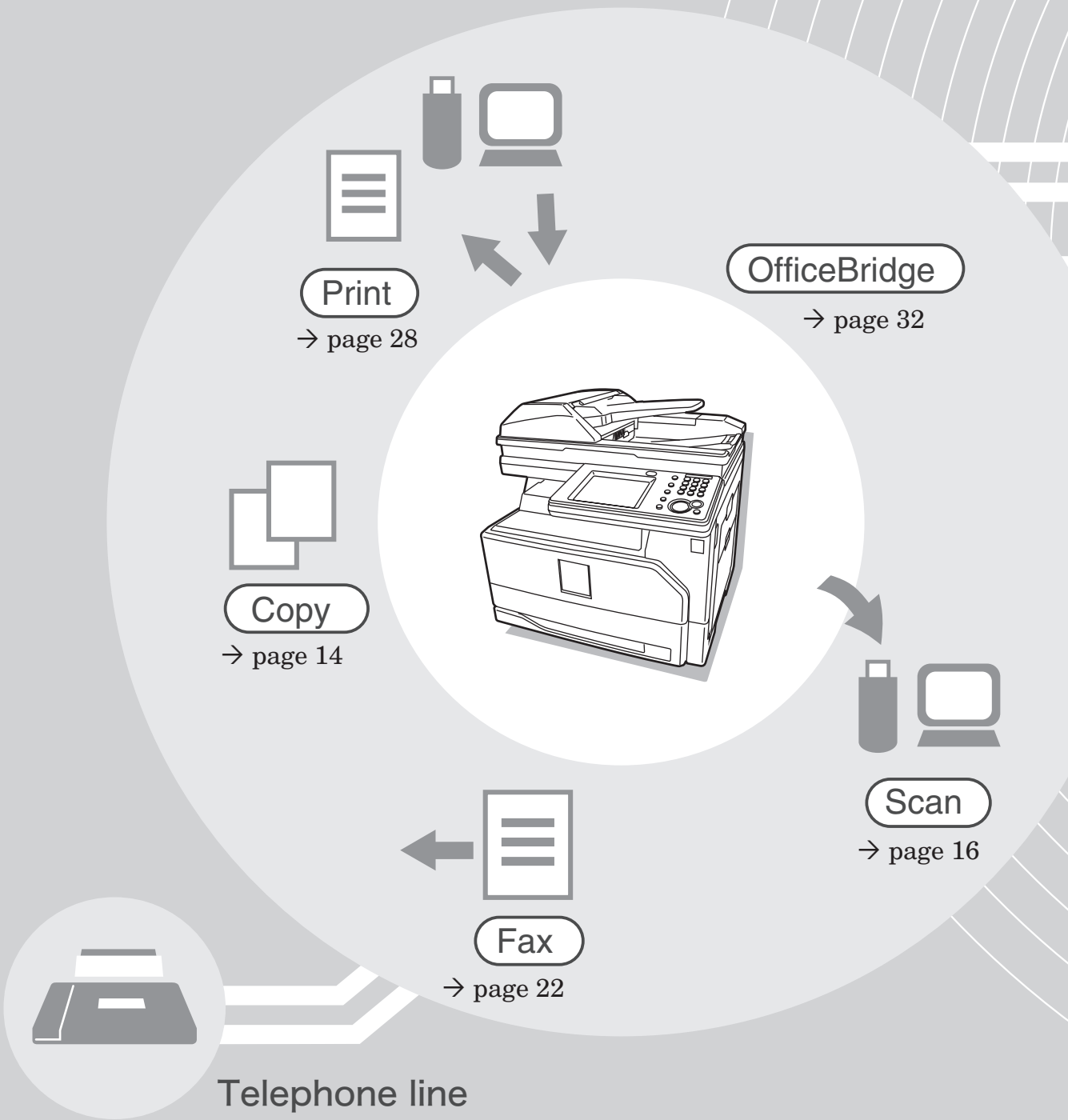

Network

LAN



Internet



The bizhub 25e is a multifunction product that can copy, scan, fax and print.

It produces letter/legal size output (the most common office document sizes) and enables users to quickly scan and deliver documents directly to their workstation.

Part names

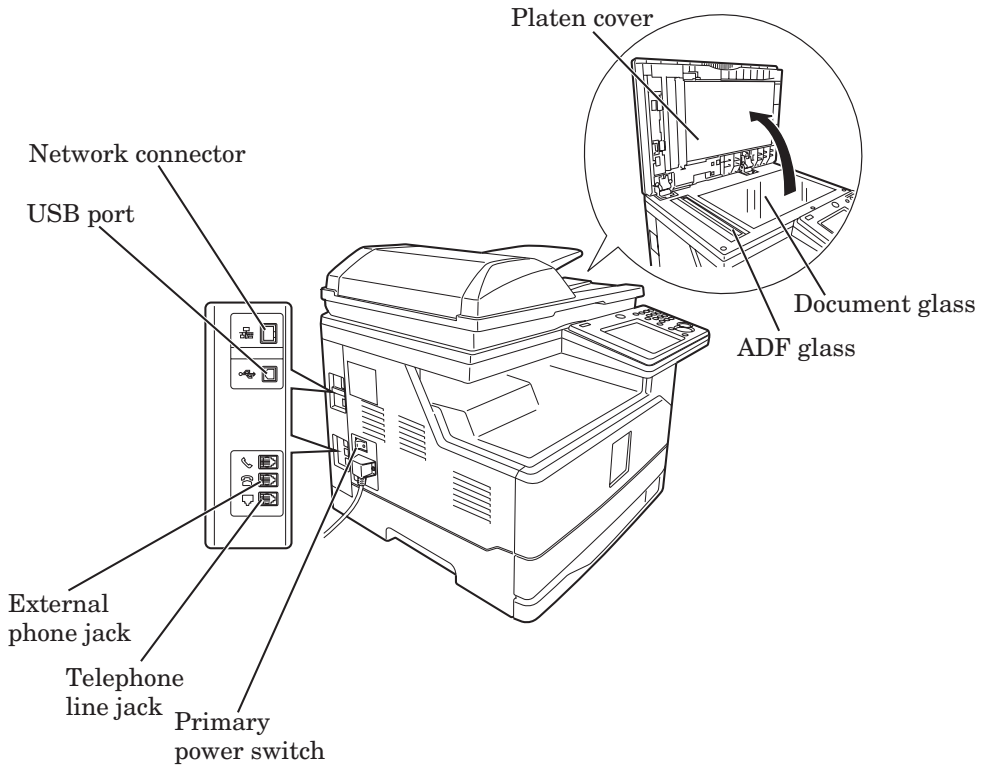
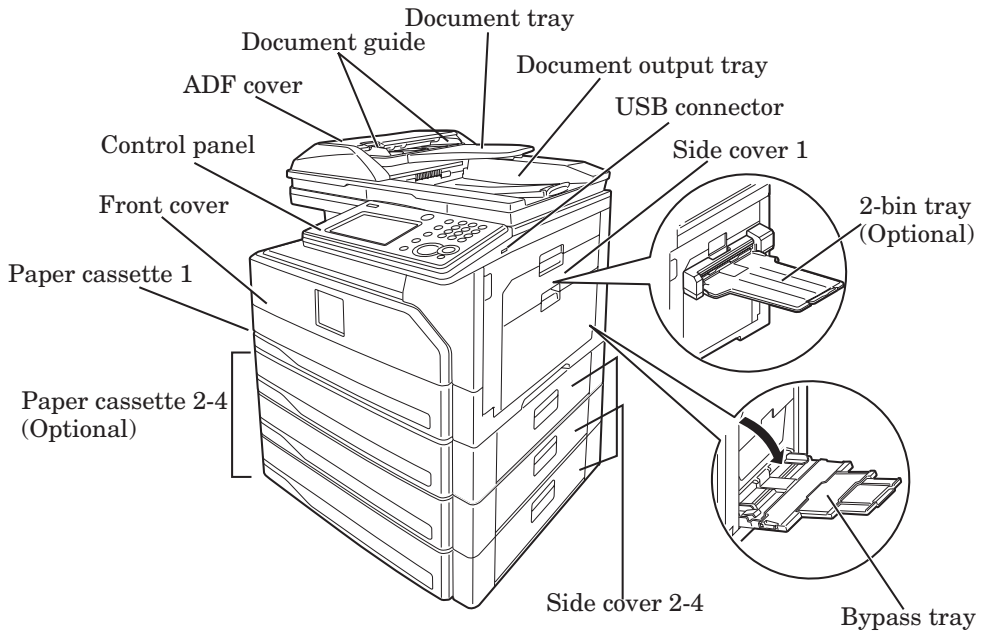

Control panel

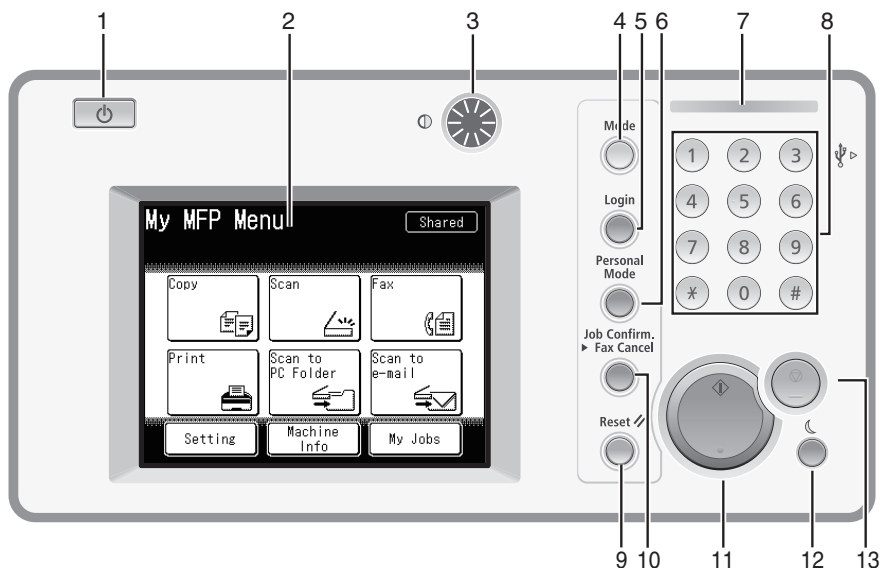

No	Name	Description
1	Power button	This button is used to turn the power on or off.
2	Display	The display shows the machine status, interactive displays, and all machine functions.
3	Display contrast dial	Adjusts the contrast of the display.
4	<Mode>	Press this key to switch the machine between copy ready screen, scan ready screen, fax ready screen, online mode (printer ready screen), and My MFP menu.
5	<Login>	Press this key to authenticate as a registered device user.
6	<Personal Mode>	Press this key to switch between the personal screen and shared screen.
7	Information lamp	Lamp illuminates when error occurs.
8	Numeric keys	Use these keys to enter numbers and characters.
9	<Reset>	Press this key to reset the settings back to the default settings and return to the ready screen.
10	<Job Confirm. ► Fax Cancel>	Press this key to confirm reserved transmissions or cancel a fax transmission.
11	<Start>	Press this key to execute the current operation.
12	<Energy Save>	Press this key to reduce energy consumption while the machine is idle, or to release the energy save mode.
13	<Stop>	Press this key to cancel the current operation.

Loading paper

Loading paper into the cassettes

■ Loading paper into the cassette

You can load up to 500 sheets of letter(8.5"×11"), legal(8.5"×14") or half-letter(5.5"×8.5") paper into the paper cassette. For details on the acceptable paper sizes, see chapter 5, "Acceptable paper" in "Specifications" in the Administrator's Guide.

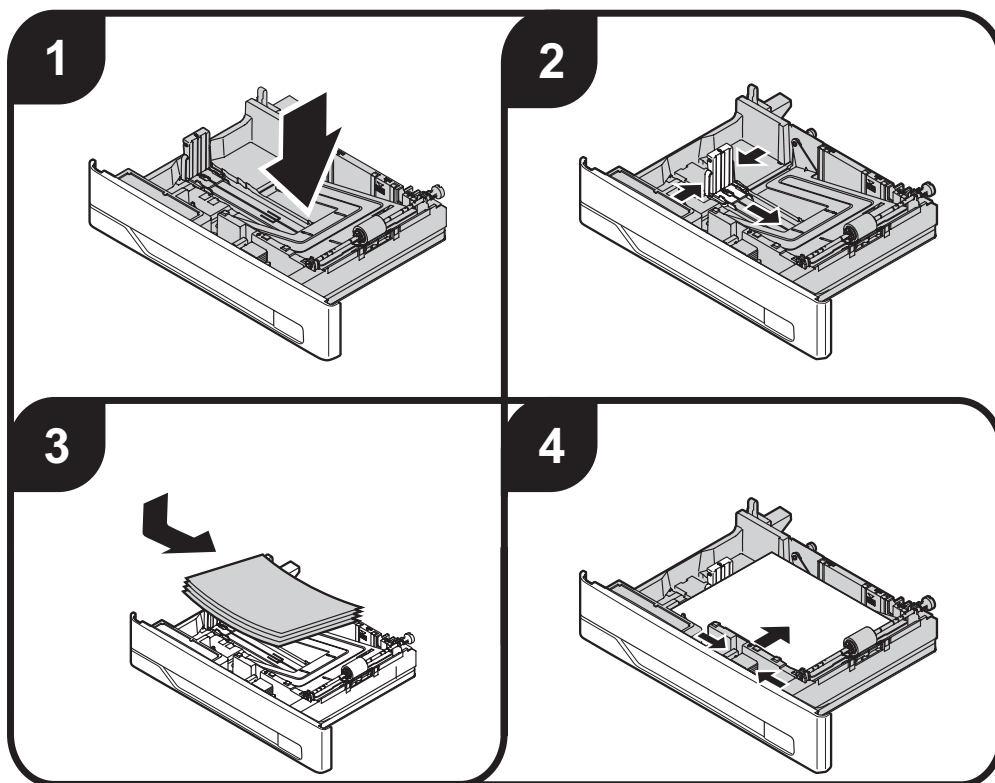

NOTE

- Do not stack paper above the paper limit mark  inside the cassette.
- Follow the instructions on the next page in order to set the paper size.
- When setting paper longer than letter, remove the guide stopper from the back of the end guide, and then replace and secure it on the groove in front of the end guide (the guide stopper will be under the paper).

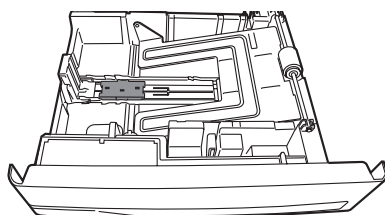

■ Setup the paper size

Setting the paper size that has been loaded into the cassette.

This operation is not required if you are loading the same size paper that was previously used in the cassette.

1 Press [Setting] on My MFP Menu screen.

If My MFP Menu screen is not displayed, press <Mode> repeatedly until My MFP Menu screen is displayed.

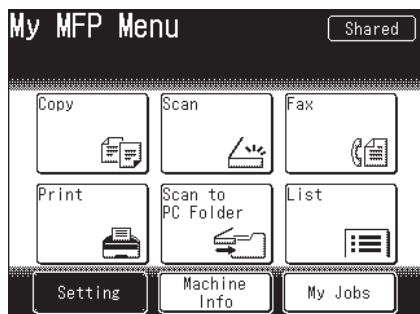

2 Press [Paper Settings].

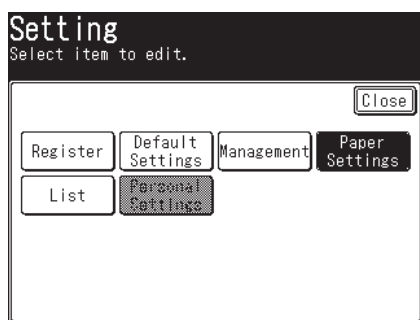

3 Select the cassette.

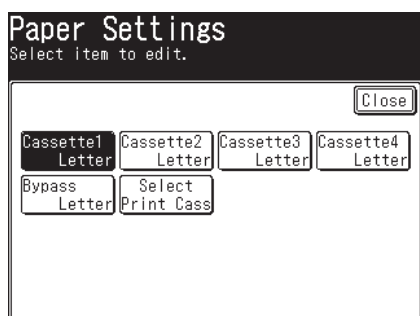

“Cassette 2” to “Cassette 4” are displayed only when the optional cassettes have been attached to the machine.

4 Select the paper size, and press [Enter].

Loading paper into the bypass tray

■ Loading paper into the bypass tray

You can load up to 100 sheets of paper. For details on the acceptable paper types, see chapter 5, “Acceptable paper” in “Specifications” in the Administrator’s Guide.

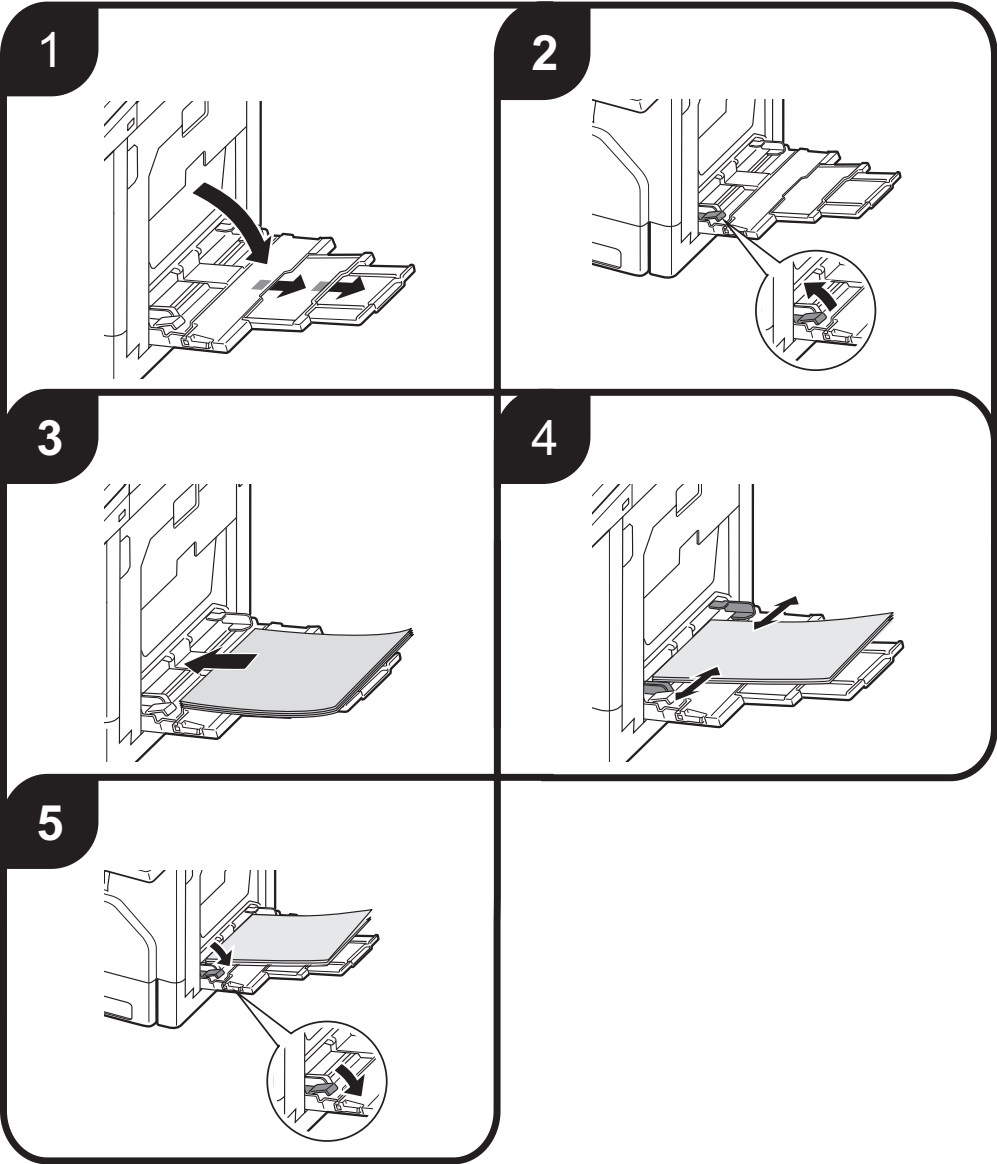

NOTE

- Set the paper face-down.
- Follow the instructions on the next page in order to set the paper size.

■ Setup the paper size

Setting the paper size that has been loaded into the bypass tray.

This operation is not required if you are loading the same size paper that was previously used in the bypass tray.

1 Press [Setting] on My MFP Menu screen.

If My MFP Menu screen is not displayed, press <Mode> repeatedly until My MFP Menu screen is displayed.

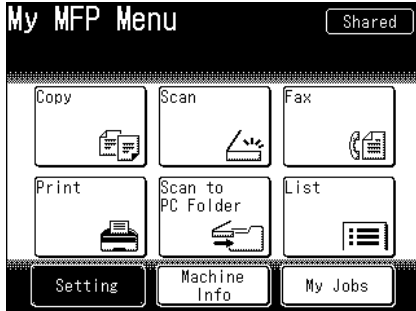

2 Press [Paper Settings].

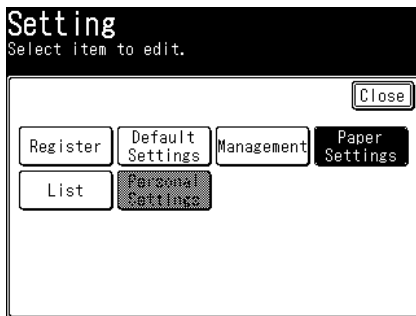

3 Press [Bypass].

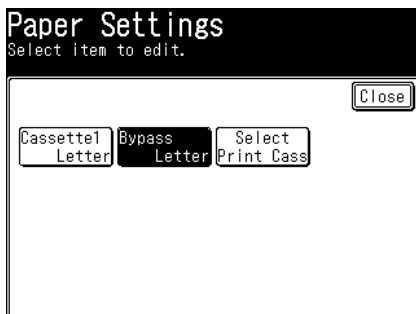

4 Select the paper size, and press [Enter].

Printing or copying on envelopes

When you print or copy on envelopes, use the following procedures to reduce wrinkles.

WARNING

The fuser unit, as well as the area around the fuser, becomes extremely hot during machine operation. When changing the switch positions, be careful not to touch other areas around the fuser unit than the switches. Doing so may cause burns.

IMPORTANT

- When you have finished printing or copying envelopes, be sure to return the switches to their original positions. If you fail to do this, the print quality may decrease.
- Do not touch the terminals inside the machine or feeder roller. This could cause defects in the print quality.

1 Open the side cover.

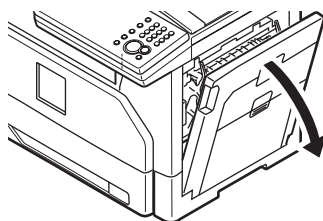

2 Pull up the switches on both sides of the fuser to the envelope positions.

Pull them up until you hear them snap into place.

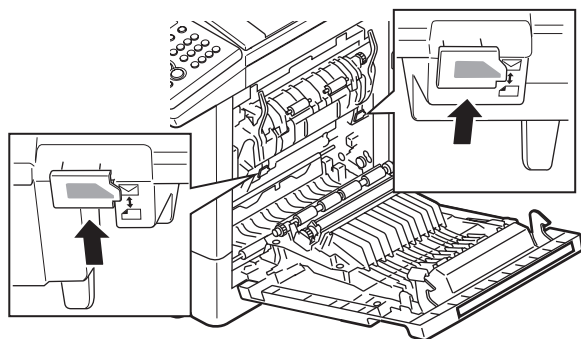

3 Close the side cover.

4 Load the envelopes into the bypass tray.

- Follow the instructions on page 8 for the details of loading.
- Follow the instructions on page 9, and set the size of the envelope.

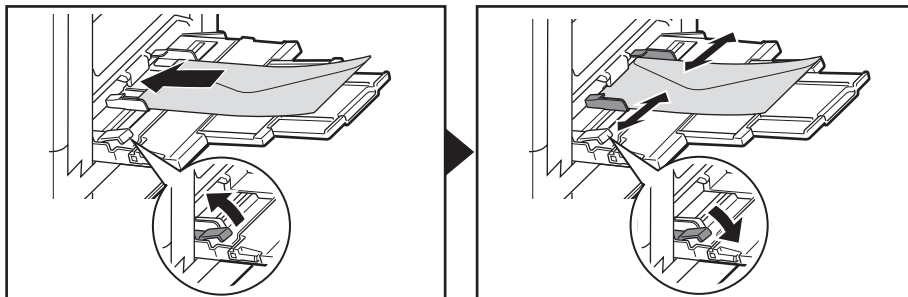

5 Print or copy.

6 Open the side cover, and return the switches to their original positions.

Pull them down until they snap into place.

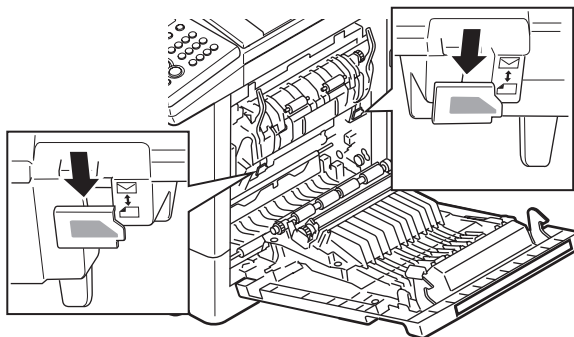

7 Close the side cover.

NOTE

When printing is finished, the following screen will be displayed. This screen will disappear either when you press [Close] or when you open the side cover. Be sure to return the switches to their original positions.

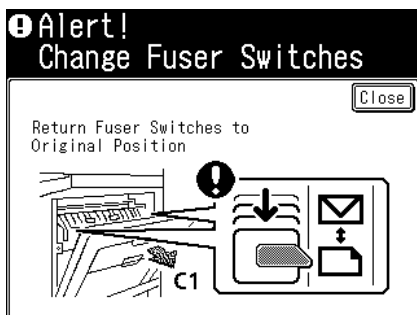

Turning the machine on and off

Turning the machine on and off (Daily use)

Before turning off the machine, make sure that the machine has completed all jobs and that the information lamp is off.

1 Press the power button.

When you are turning the power off, "Shutting down" will be displayed, and then the display turns off.

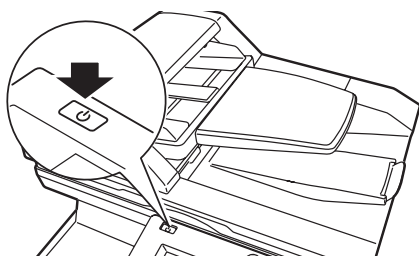

Turning the machine on and off (Long time off)

⚠ CAUTION

Before turning the primary power switch off, please make sure the secondary power switch has been turned off.

■ Turning the machine off

When you do not use the machine for a long time, be sure to turn the primary power off.

1 Press the power button.

When you are turning the power off, "Shutting down" will be displayed, and then the display turns off.

2 Switch the primary power switch to off.

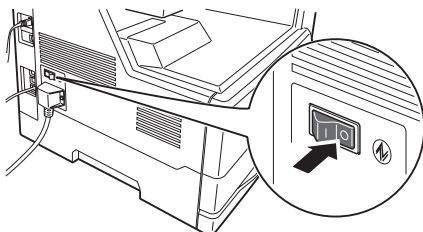

■ Turning the machine on

1 Switch the primary power switch to on.

NOTE

When you turn the primary power off for more than 72 hours, date and time information are lost. When you turn the power on after that, the date and time entry screen will be displayed.

About the display screens

Ready screens

You can switch the machine between copy ready screen, scan ready screen, fax ready screen, online mode (print ready screen), and My MFP menu by pressing <Mode>.

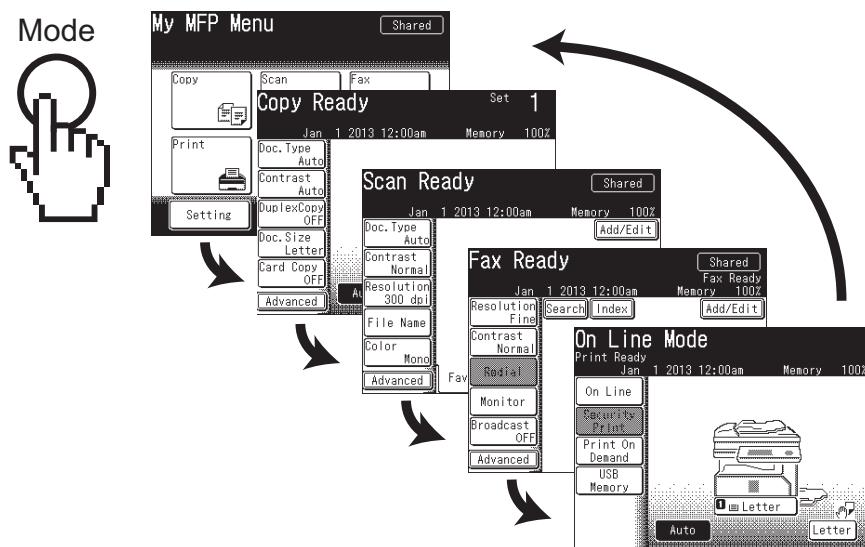

My MFP Menu screen

You can enter the following menu from My MFP Menu screen.

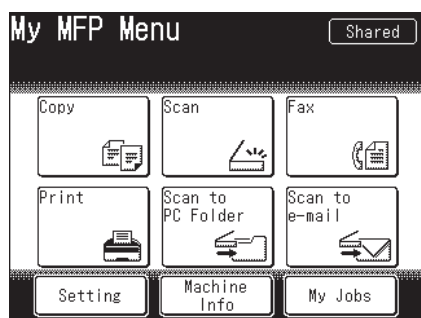

Menu	Description
Copy, Scan, Fax, Print	Select these menu to enter to copy, scan, fax or online mode (print ready screen).
Scan to PC Folder	Select this to scan a document and save the data on a PC folder. For details, see page 16.
Scan to e-mail	Select this to scan a document and send it via e-mail. For details, see page 16.
Setting	Select this to enter machine setting menu.
Machine info	Select this to display the machine information which includes the page counter data.
My Jobs	Select this to execute a “My Jobs” process. For details, see chapter 1, “Using My Jobs” in the Administrator’s Guide.

Copy

Basic operation

See the Copier Guide for more information.

1 Set the document.

In the automatic document feeder

- ① Set the document face up.
- ② Align the document guides to the document width.

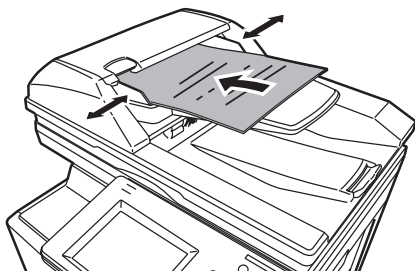

On the document glass

- ① Open the platen cover.
- ② Set the document face down aligned with the back left corner.
- ③ Close the platen cover.

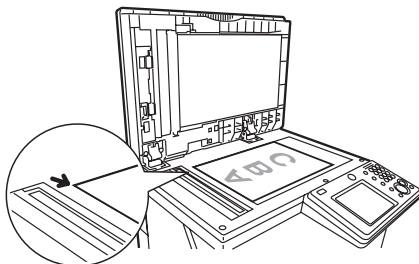

NOTE

When you set a document on the document glass, be sure that there are no documents in the automatic document feeder.

2 Switch the machine to copy mode.

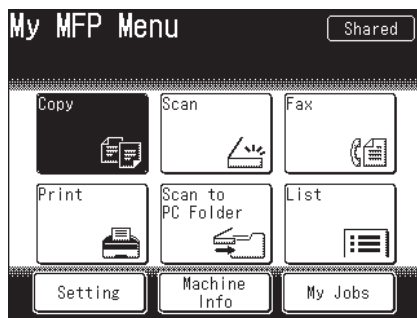

Press [Copy] from My MFP menu screen. Or, press <Mode> repeatedly until copy ready screen is displayed.

3 Change the settings if needed.

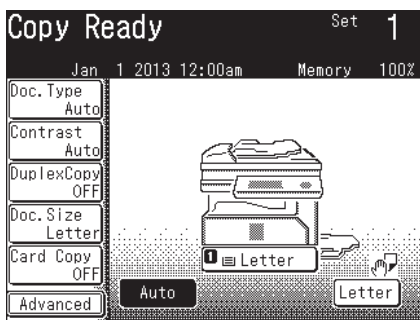

- To make two or more copies enter the desired number of copies using the numeric keys.
- Press [Advanced] to set advanced settings.

4 Press <Start>.

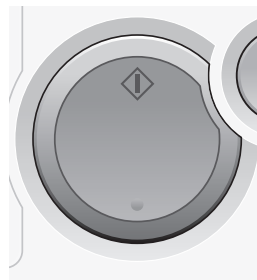

Press <Stop> to stop the copy job.

Advanced settings

Here are a few examples of useful copy settings. See the Copier Guide for more information.

- Combined copy

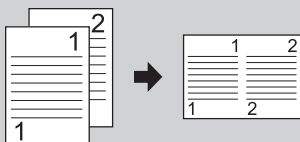

- Card copy



- Sorting

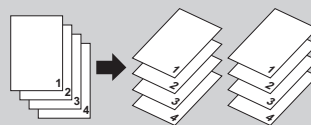

Basic operation

See the Scanner and Fax Guide for more information.

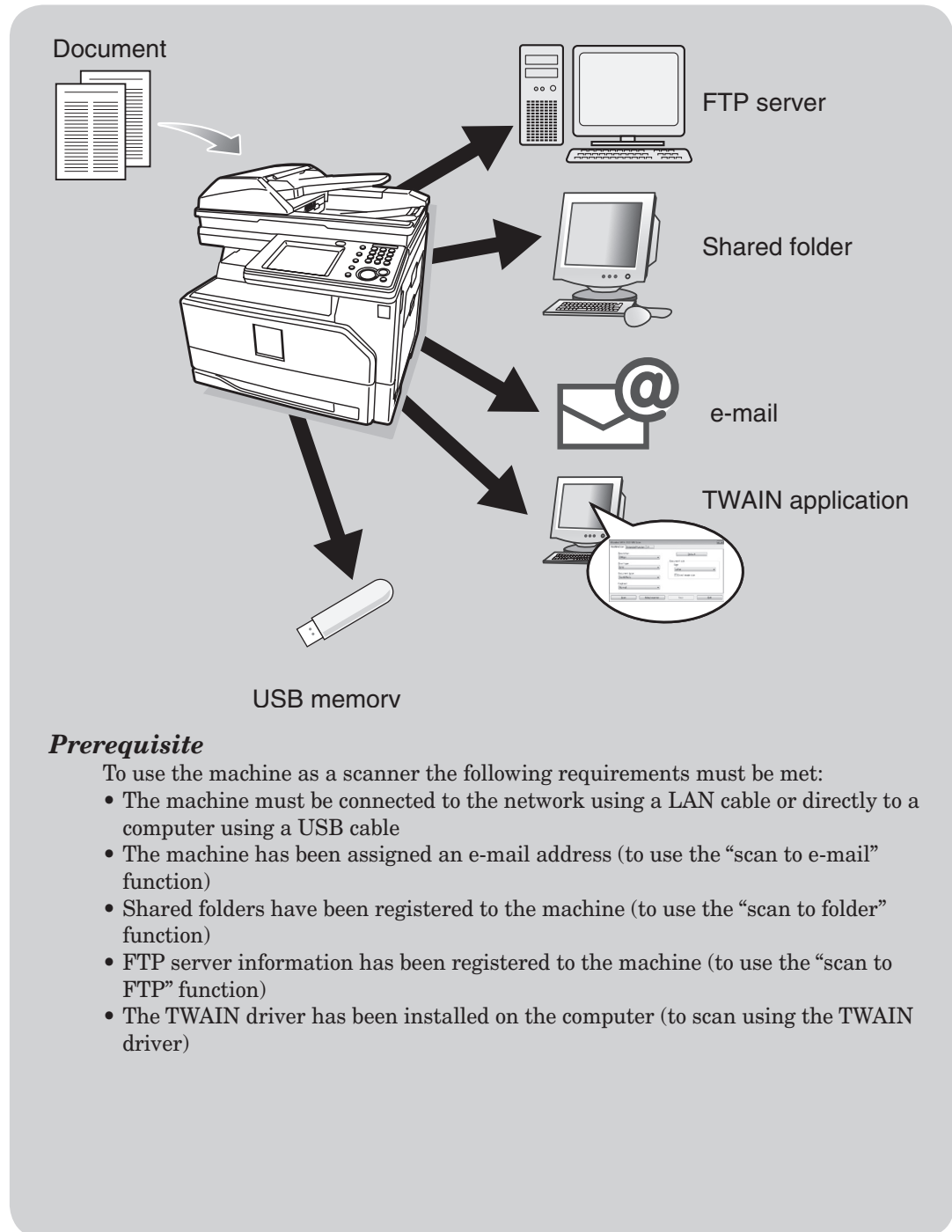

Prerequisite

To use the machine as a scanner the following requirements must be met:

- The machine must be connected to the network using a LAN cable or directly to a computer using a USB cable
- The machine has been assigned an e-mail address (to use the “scan to e-mail” function)
- Shared folders have been registered to the machine (to use the “scan to folder” function)
- FTP server information has been registered to the machine (to use the “scan to FTP” function)
- The TWAIN driver has been installed on the computer (to scan using the TWAIN driver)

1 Set the document.

In the automatic document feeder

- ① Set the document face up.
- ② Align the document guides to the document width.

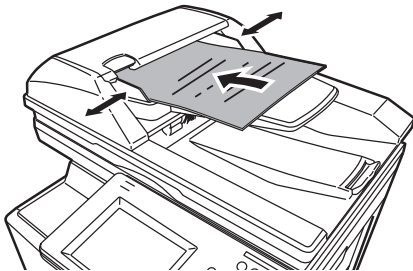

On the document glass

- ① Open the platen cover.
- ② Set the document face down aligned with the back left corner.
- ③ Close the platen cover.

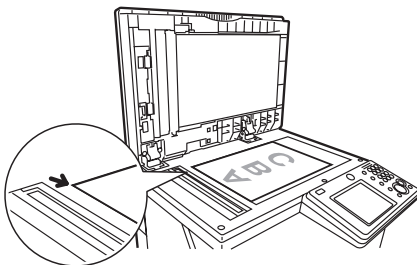

NOTE

When you set a document on the document glass, be sure that there are no documents in the automatic document feeder.

2 Switch the machine to scan mode.

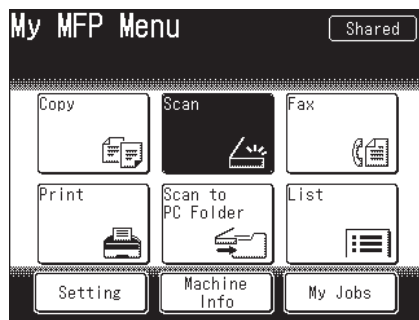

Press [Scan] from My MFP menu screen. Or, press <Mode> repeatedly until scan ready screen is displayed.

NOTE

To use the personal address book or shortcuts, log in to the machine. See chapter 1, “Logging in / Logging out” in the Administrator’s Guide.

3 Select the destination.

Scan to e-mail

① Press [e-mail].

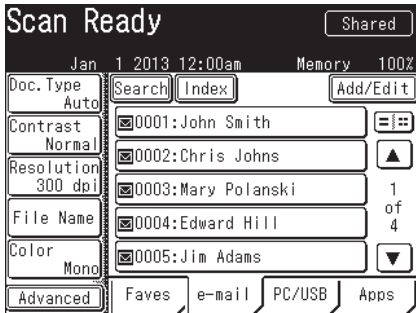

② Specify the destination.

Select your desired destination from the display.

or

Press [Advanced] → [Mail Address] and enter the e-mail address of your desired destination. Press [Enter].

Scan to Folder / Scan to FTP

① Press [PC/USB].

② Press [Folder] or [FTP].

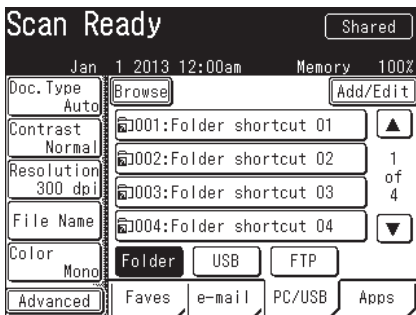

③ Specify the destination.

Select your desired destination from the display.

or

Press [Browse] and browse to your desired folder. Select the folder and press [Enter]. Enter the user ID and password to enter the folder, if required.

or

Press [Host] and enter the details on your desired FTP server. Press [Enter].

Scan to USB

① Press [PC/USB].

② Press [USB].

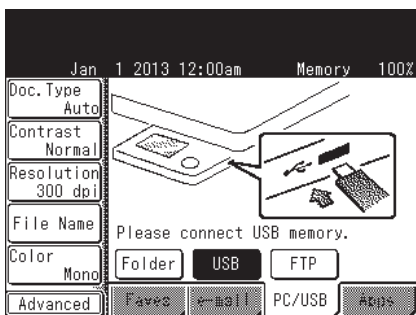

③ Connect the USB memory device to the control panel.

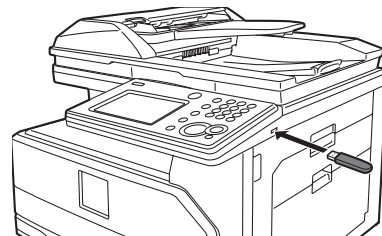

4 Press <Start>.

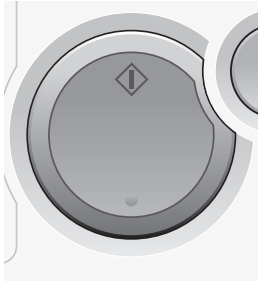

- This step is not necessary when you have selected the destination from the address book or shortcut.
- If the document was set on the document glass, “Set next document.” will be displayed once the scan has been completed. Press [Complete] to complete the operation, or set the next document on the document glass and press [Next Doc].

Advanced scan settings

See the Scanner and Fax Guide for more information.

■ Entering a file name

The default file name for scanned images is a 14-digit number consisting of the current year, month, day, hour, minute, and second. ex.: 20130115143045.pdf. You can customize the file name when scanning.

1 Switch the machine to scan mode.

2 Press [File Name].

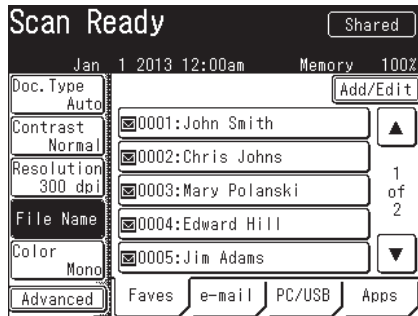

3 Enter the file name, and press [Enter].

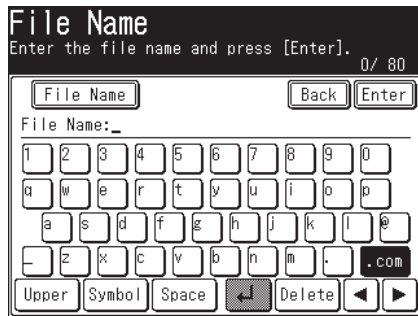

- Press [Delete] to clear the entered characters.
- Press [Upper] to switch the entry mode from lower case to upper case, and [Symbol] to symbols, then [Lower] to lower case again.
- For more details on entering the characters, see chapter 1, “Entering characters” in the Administrator’s Guide.
- You can also enter the file name using a file name registered in advance. For more details, see chapter 2, “File Name” in “Advanced scan functions” in the Scanner and Fax Guide.

■ Scanning color documents

- 1 Switch the machine to scan mode.
- 2 Press [Color].

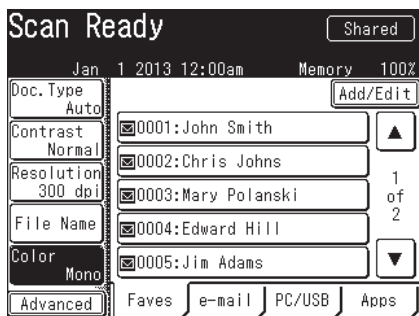

The button switches between “Mono” and “Color” each time you press [Color].

■ Selecting the file format

Scanned images will be converted into PDF format as the factory default. You can also convert images into TIFF format (monochrome), JPEG (color), or PDF with password (monochrome and color).

- 1 Switch the machine to scan mode.
- 2 Press [Advanced].
- 3 Press [File Format].
- 4 Select the file format, and press [Enter].
 - When you have selected [PDF w/ Password], press [Setting] and set the details for encryption.
 - When you have selected [PDF w/ Password], you can set password to open the file and to edit the file after you have pressed <Start>. For details, see chapter 2, “File format” in “Advanced scan functions” in the Scanner and Fax Guide

Basic transmission

See the Scanner and Fax Guide for more information.

Prerequisite

To send and receive faxes, the following requirements must be met:

- The telephone line cable has been connected to the machine and the wall outlet.
- The machine has been setup for communication. For details, see chapter 7, “Initial setup (User Install)” in the Scanner and Fax Guide.

1 Set the document.

In the automatic document feeder

- ① Set the document face up.
- ② Align the document guides to the document width.

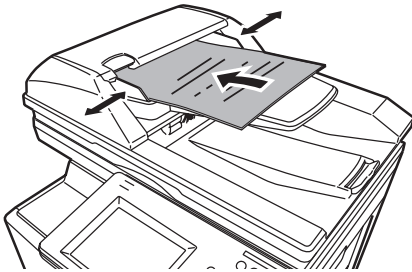

On the document glass

- ① Open the platen cover.
- ② Set the document face down aligned with the back left corner.
- ③ Close the platen cover.

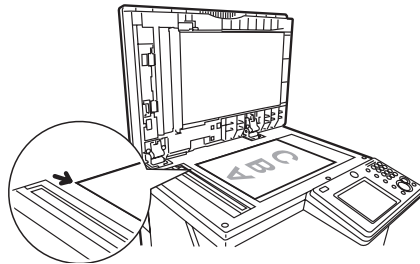

NOTE

When you set a document on the document glass, be sure that there are no documents in the automatic document feeder.

2 Switch the machine to fax mode.

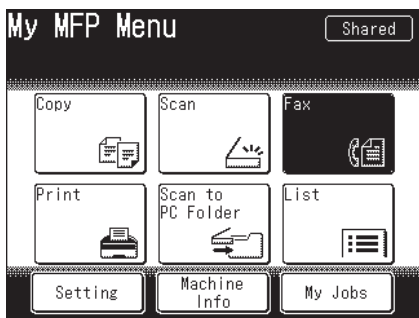

Press [Fax] from My MFP menu screen. Or, press <Mode> repeatedly until fax ready screen is displayed.

NOTE

To use the personal address book, log in to the machine. See chapter 1, “Logging in / Logging out” in the Administrator’s Guide.

3 Enter destination.

Direct input

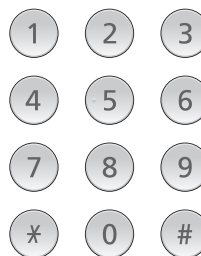

Use the numeric keys to enter the fax number and press [Enter].

Using the address book

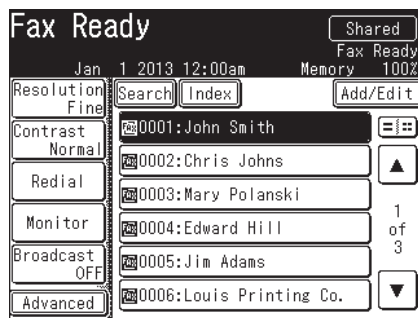

Press the desired destination.

To use the address book, the fax number should be registered in advance. For details, see “Registering e-mail and fax destinations” (page 34).

4 Press <Start>.

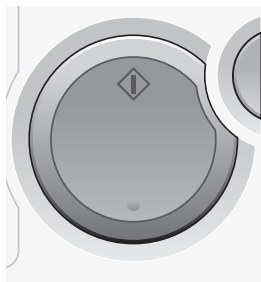

- This step is not necessary when you have selected the destination from the address book.
- If the document was set on the document glass, “Set next document.” will be displayed once the scan has been completed. Press [Tx Start] to complete the operation, or set the next document on the document glass and press [Next Doc].

How to specify multiple destinations...

When you specify multiple destinations using the address book, set “Broadcast” to ON before specifying the destinations.

When you specify destinations using the numeric keys, “Broadcast” setting will be turned ON automatically when you enter a destination.

How to confirm destinations...

When you have selected multiple destinations, you can confirm the destinations using the following operation:

- 1 When all destinations have been selected, press [Location].
- 2 Confirm the destinations.
- 3 To start the transmission, press <Start>. To delete a destination, select the destination and press [Delete].

How to receive a fax...

As a default setting your machine will automatically receive faxes.

Canceling the transmission

Here we describe how to cancel faxes that are being transmitted.

- 1 Press <Job Confirm.>▶<Fax Cancel.>.



- 2 Press [Delete].

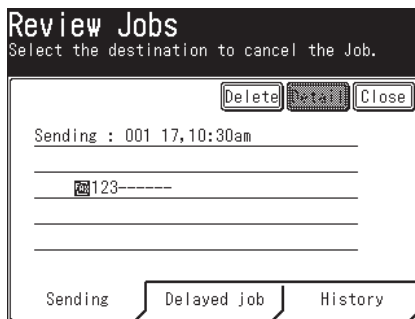

When you have scheduled a broadcast, you can remove a destination from the transmission by pressing [Detail].

Select the destination to delete and press [Delete].

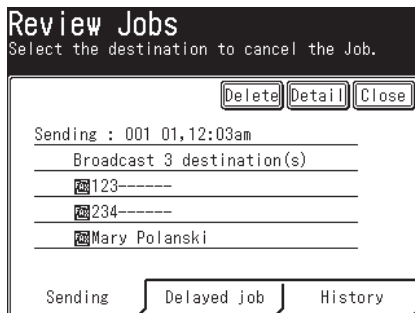

NOTE

For details on canceling a delayed transmission, see chapter 3, “Canceling / Checking faxes” in “Basic faxing” in the Scanner and Fax Guide.

PC-Fax

See the Scanner and Fax Guide for more information.

Prerequisite

To send a fax from the computer, the following requirements must be met:

- The telephone line cable has been connected to the machine and the wall outlet.
- The machine has been setup for communication. For details, see chapter 7, “Initial setup (User Install)” in the Scanner and Fax Guide.
- The machine is connected to a network.
- The machine and the computer from which you are going to send a PC-Fax are on the same segment of the network.
- The fax driver has been installed on the computer. For details on installing the driver, see chapter 1, “Installing to Windows” in the Printer Guide.

1 Create or edit the document on your computer.

2 Select “Print” from menu.

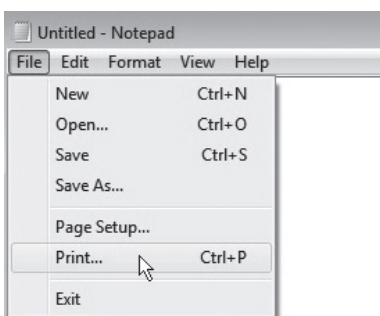

According to the application software you are using, the command name may be something other than “print”.

3 Select the bizhub 25e fax driver from the print menu.

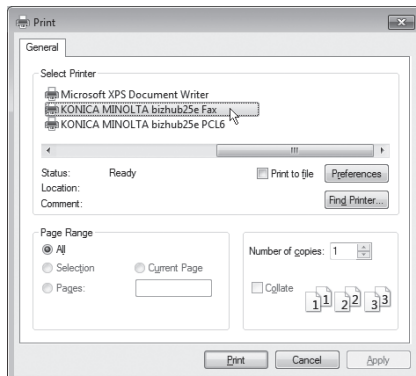

- The driver name is “KONICA MINOLTA bizhub 25e”.
- Click [Preferences] to change the settings as needed.
- To use your personal address book, register your user name to the driver. For details, see chapter 2, “Printer setting screen details” in “Setting the printer” in the Printer Guide.

4 Click [Print].

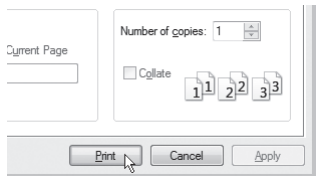

6 Click [Send].

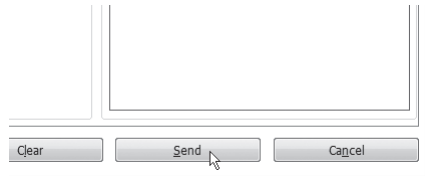

5 Enter the destinations.

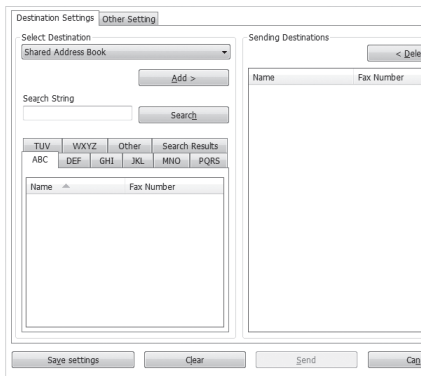

Select “Shared Address Book”, “Personal Address Book”, or “Direct Input”. When you have selected “Shared Address Book” or “Personal Address Book”, select the desired address. When you have selected “Direct Input”, enter your desired fax number to the “Fax Number” column. Then click [Add].

Print

Basic operation

See the Printer Guide for more information.

Prerequisite

To print from the computer, the following requirements must be met:

- The machine has been connected to the network using a LAN cable or directly to a computer using a USB cable.
- A printer driver has been installed on the computer. For details on installing the drivers, see chapter 1, “Installing the driver” in the Printer Guide.

1 Select “Print” from the menu.

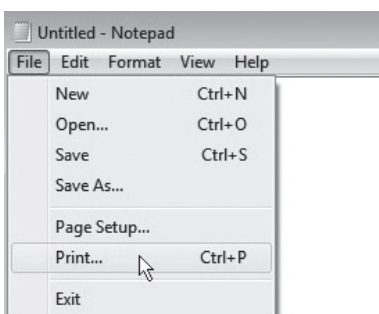

According to the application software you are using, the command name may be something other than “print”.

2 Select the bizhub 25e printer driver.

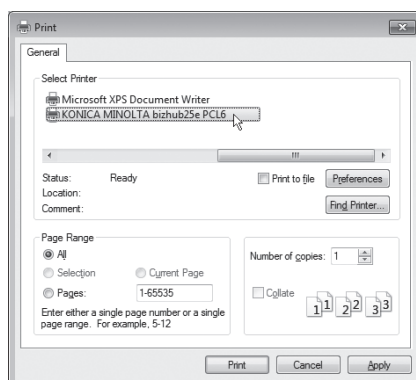

Click [Preferences] to change the settings as needed.

3 Change preferences as needed.

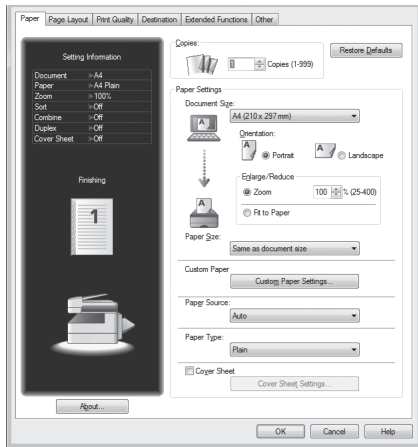

4 Click [Print].

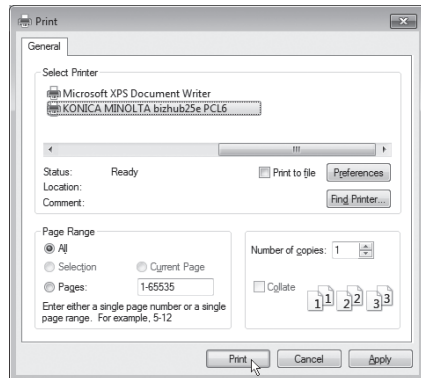

Advanced settings

Here are a few examples of the advanced print settings.
See the Printer Guide for more information.

- Duplex printing

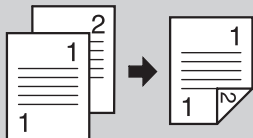

- Sorting

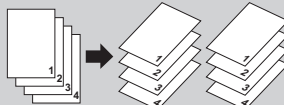

- Printing water mark



Canceling a print job

When canceling a print job, first try to cancel it on the computer. If you cannot cancel printing on the computer, cancel it on the machine.

■ Canceling printing on the computer

- 1 Double click the printer icon on the computer.
- 2 Right click on the print job you wish to cancel, and click [Cancel].

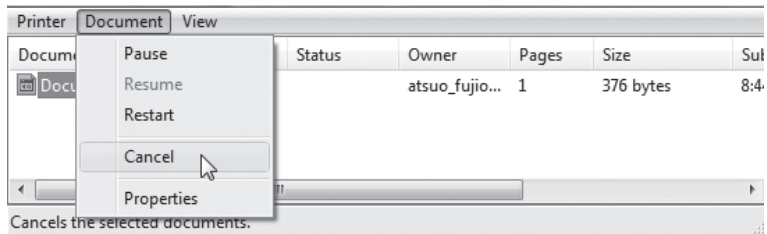

■ Canceling printing on the machine

- 1 Press [Print] from My MFP menu screen.
Or, press <Mode> repeatedly until “On Line Mode” screen is displayed.
- 2 Press [On Line].

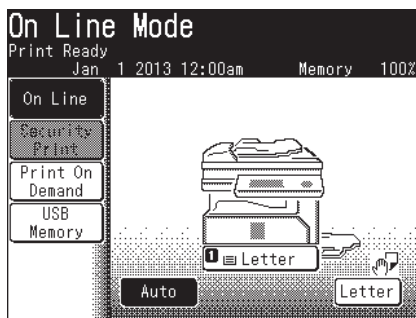

- 3 Select the file to cancel, and press [Delete].
- 4 Press [Yes].

Printing from a USB memory device

You can print documents you have scanned with your machine.

- 1 Connect the USB memory device to the machine.

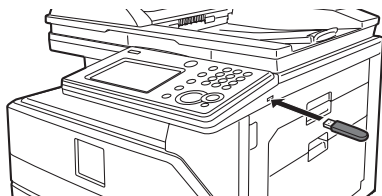

- 2 Select [USB To Print].

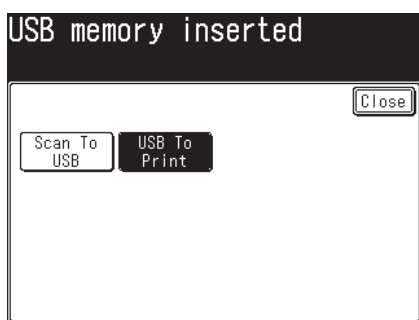

- 3 Press [Browse].
 - Press [Root] to return the list of root folders.
 - Press [Back] to go one screen back.
 - To review the document properties, press the  icon located next to the file name.
- 4 Select the file to print, and press [Enter].

You cannot select multiple files at the same time.
- 5 Press <Start>.

You can set the number of sets, paper source, sorting or enter PDF password on the screen. For details, see chapter 4, "Printing documents saved in USB memory" in the Printer Guide.
- 6 When printing is finished, disconnect the USB memory device.

NOTE

For details on printable documents, see chapter 4, "Printing documents saved in USB memory" in the Printer Guide.

Using Message Board

Accessing Message Board

When the machine is connected to the network, you can operate it using the web browser on your computer.

See the Message Board Guide for more information.

Prerequisite

To use Message Board, the following requirements must be met:

- The machine is connected to a network.
- There is a web browser application installed on the computer from which you access the machine.

- 1** On the web browser, enter the machine IP address and press the enter key.

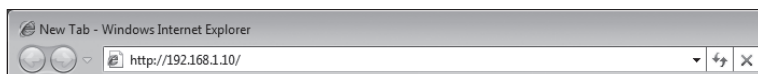

- We are using Internet Explorer for this example.
- If a shortcut to Message Board has been created on the desktop, double-click it.

- 2** Click [User Login].

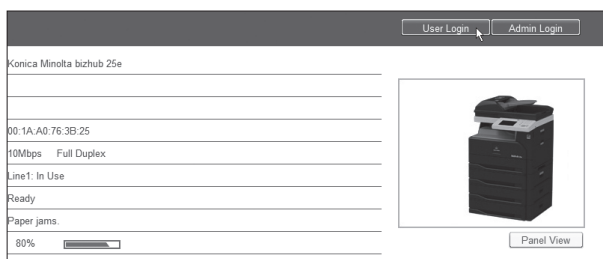

3 Enter the user ID, and password and click [Login].

Number	Name	Group
001	User_001	JOHO_SOFT

- If a user has not been registered, this step is not necessary.
- To access Message Board as a guest, click [Guest User Login].
- To log in using SSL, click [SSL(https)] and then enter user ID and password.
- When the user list is displayed on the right, you can enter the user ID by selecting your user name on the list.

Now you can access the machine using Message Board.

Scan Count	Copy	Fax	Scanner	Total
	6	3	10	19

Registering e-mail and fax destinations

See the Message Board Guide for more information.

1 Click “User Information”.

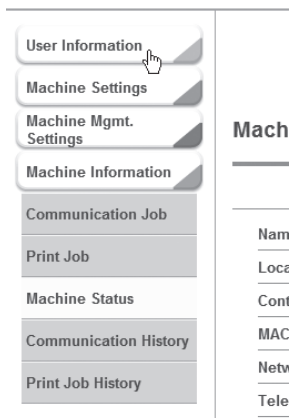

For details on how to access Message Board, see “Accessing Message Board” (page 32).

NOTE

According to the user policy, you cannot edit the address book. For details on the user policy, see chapter 4, “Setting user policies” in the Message Board Guide.

2 Click “Address Book”.

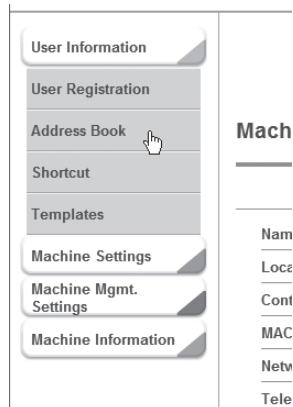

3 Click [Add].



To add a destination to your personal address book, select “Personal” from the drop down box located to the left of the [Add] button. Personal address books may not be available based on the administrator settings or authentication rules.

4 Enter the contact information and click [Save].

Shared Address Book > Registration

Search

Number

Name

Fax Number

E-mail Address

PIN

Super G3 ON OFF

- Search : To search for the contact information, click this button. For details, see chapter 2, “Registering destinations” in “Registering addresses” in the Message Board Guide.
- Number : The lowest available address book number will be displayed. You can change it to any available number between 1 - 9999.
- Name : Enter the destination name within 30 characters.
- Fax Number : Enter the fax number. Pause, tone and other dialing options should be entered with the fax number.
See the table below for instructions on entering the dialing options.
- E-mail Address : Enter the e-mail address.
- PIN: If your phone line requires entering a personal identify number (PIN) prior to completing a phone call, enter that number here.
- Super G3: Set whether to transmit with Super G3.

Table for dialing options

Dialing options	How to enter	Example
Hyphen	-	111-1111-1111
Pause	/P	2/P222-2222-2222
Tone	/T	3/T333-3333-3333
Prefix	/N	/N444-4444-4444

NOTE

You can also register an e-mail or fax destination from the machine control panel. In this case, press [Setting] from My MFP Menu → [Register] → [Address Book Entry] → [Enter/Edit]. Then select an available number to enter the contact information. After entering the contact information, press [Enter] to save the information.

Registering a folder or FTP destination

See the Message Board Guide for more information.

1 Click “User Information”.

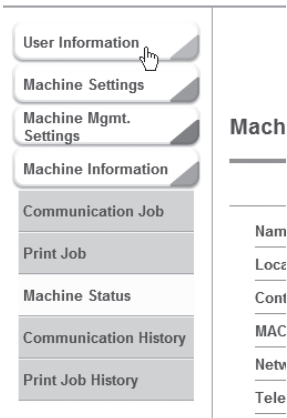

For details on how to access Message Board, see “Accessing Message Board” (page 32).

NOTE

According to the user policy, you cannot edit the shortcut. For details on the user policy, see chapter 4, “Setting user policies” in the Message Board Guide.

2 Click “Shortcut”.

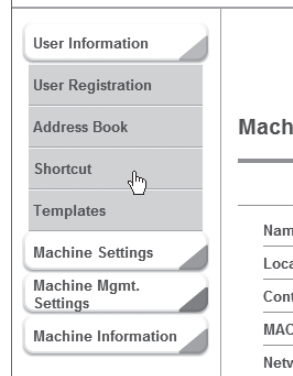

3 Click “Folder Shortcut” or “FTP Shortcut”.

Shortcut

Folder Shortcut Folder shortcut re

FTP Shortcut FTP shortcut re

4 Click [Add].

To add a folder shortcut to your personal shortcut, select “Personal” from the drop down box located to the left of the [Add] button. Personal folder shortcut may not be available based on the administrator settings or authentication rules.

5 Enter the shortcut information and click [Save].

Details for folder shortcut

Shortcut > Folder Shortcut > Setting

Shortcut Number	<input type="text" value="001"/>	
Shortcut Name	<input type="text"/>	
Folder Path	<input type="text"/>	<input type="button" value="Browse"/>
User Name	<input type="text"/>	
Password	<input type="text"/>	<input checked="" type="checkbox"/> Change Password
Auto Login	<input checked="" type="radio"/> ON <input type="radio"/> OFF	

- **Shortcut Number :** The lowest available number will be displayed. You can change it to any available number between 1 - 300.
- **Shortcut Name :** Enter the shortcut name within 24 characters.
- **Folder Path :** Enter the path to the folder. When you click [Browse], a screen will open allowing you to browse to the location.
- **User Name :** Enter the user name for the folder if needed.
- **Password:** Enter the password for the folder if needed.
- **Auto Login:** Check "ON" to enable log in using the saved user name and password.

Details for FTP shortcut

- **Shortcut Number :** The lowest available number will be displayed. You can change it to any available number between 1 - 20.
- **Shortcut Name :** Enter the shortcut name within 24 characters.
- **Host Name :** Enter the host name within 126 characters.
- **Folder Path :** Enter the path to the folder. Enter the host name and click [Browse], then enter the user name and password. A screen will then open allowing you to browse to the location.
- **User Name :** Enter the user name.
- **Password:** Enter the password.
- **PASV Mode :** Check "ON" to enable access in PASV mode.
- **Port Number :** Modify the port number if needed.

Replacing the consumables

Replacing the toner cartridge

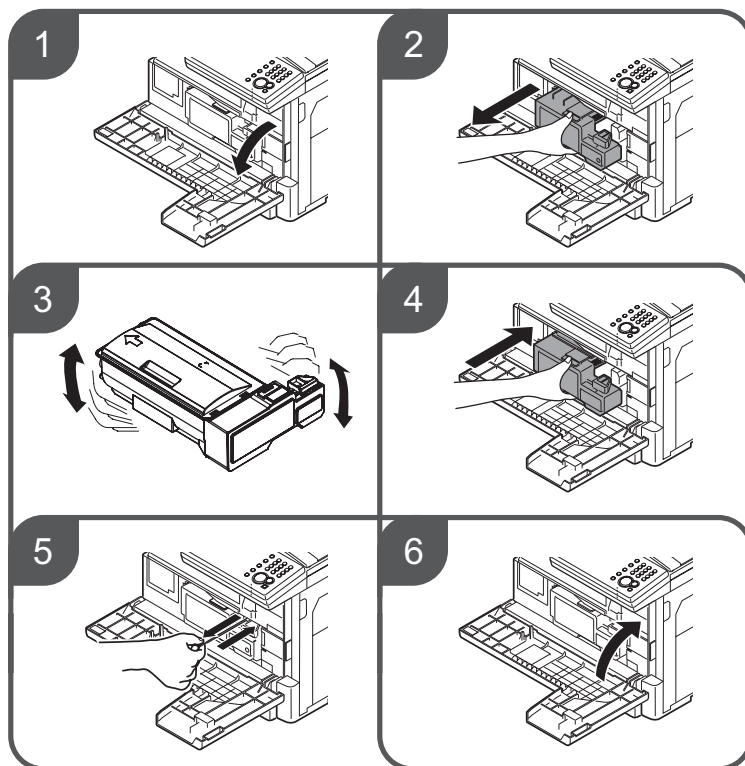

NOTE

- The shape of the new toner cartridge differs from what has been set at the shipment.
- Before you set the new toner cartridge, gently shake it to distribute the toner evenly inside the cartridge.
- When you have changed the toner cartridge, clean the charge needle by pulling the charging needle cleaning rod. Making sure it fully extends, and then return the rod to its original position. Perform this several times.
- When you have replaced the toner cartridge, the following screen will be displayed. Press [Yes] to use the new toner cartridge.

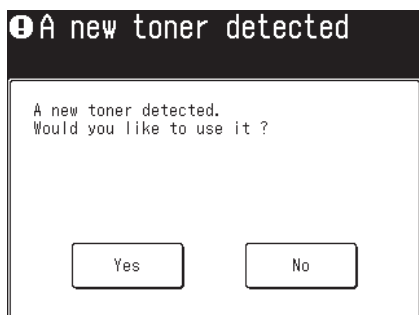

Replacing the drum cartridge

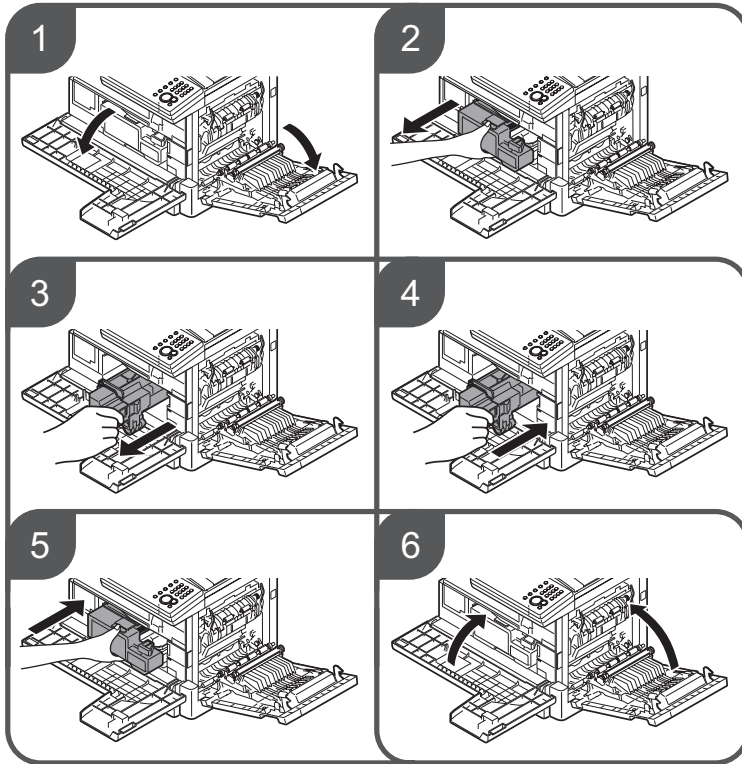

NOTE

When you have replaced the drum cartridge, the following screen will be displayed. Press [Yes] to use the new drum cartridge.



Clearing document jams

Clearing document jams

Document jam

Open flashing cover and check.

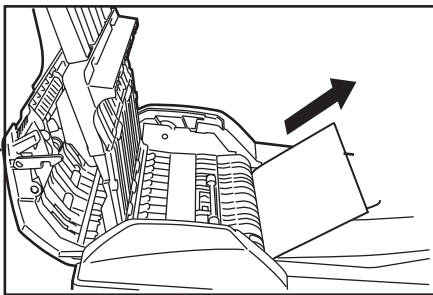
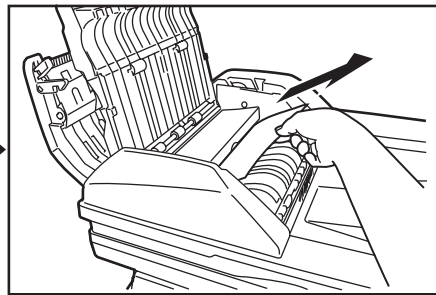
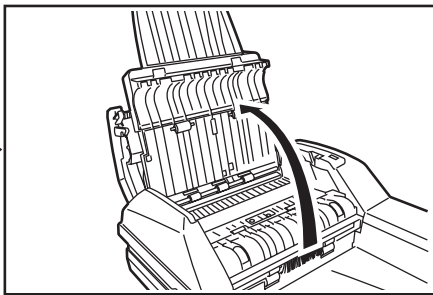
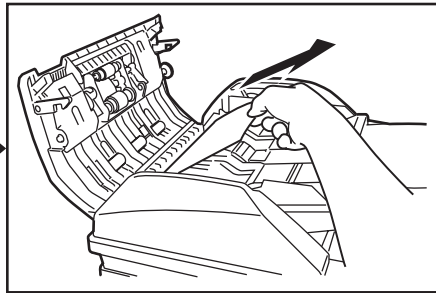
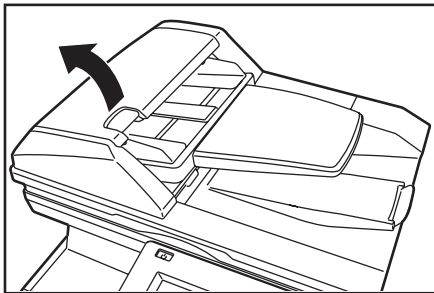
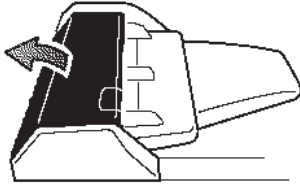

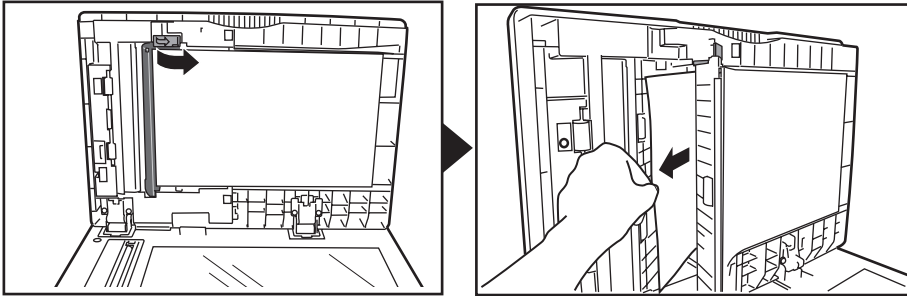

Document jam recovery

When the following message appears after you have cleared the jam, you can restart scanning from the continuous page of the document.

Set the document from the page listed on the display, then press [Start].



Clearing paper jams

⚠ WARNING

- The fuser unit, as well as the area around the fuser, become extremely hot during machine operation. When attempting to clear a paper jam, or inspect the inside of the machine, be careful not to touch areas around the fuser unit. Doing so may cause burns.
- When removing jammed paper be careful not to get toner in your eyes or mouth. If the toner gets in your eyes or mouth, immediately flush with clean water and seek medical assistance.

! IMPORTANT

- If a paper jam occurs during printing, the toner will not be fused to the paper. Be careful not to stain your hands or clothes with the toner. If your hands or clothes get stained, wash them immediately with cold water. The stains may become permanent if washed using warm water.
- Carefully remove the jammed paper so as not to leave fragments of paper inside the machine.
- Do not touch the terminals inside the machine or feeder roller. This could cause defects in the print quality.
- Do not expose the drum cartridge to light for more than five minutes.
- Do not touch the drum surface. This could cause a recording error.

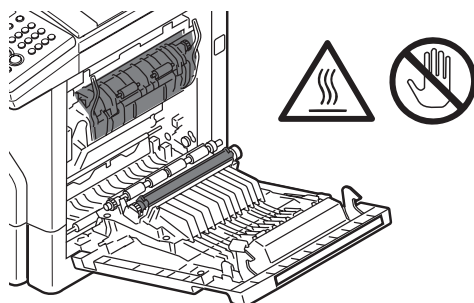

❗ Paper jam

Open flashing cover and check.

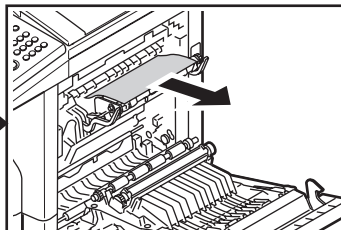
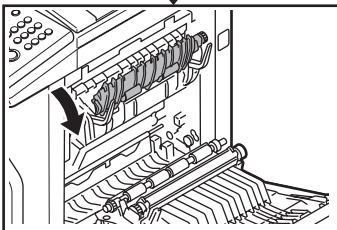
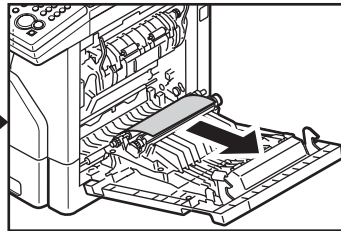
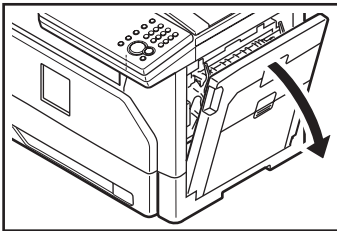
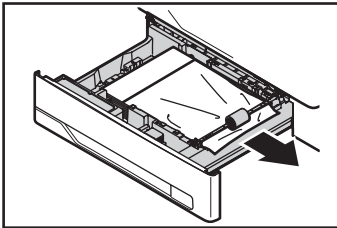
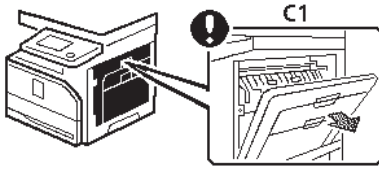

Clearing paper jams in the optional cassette

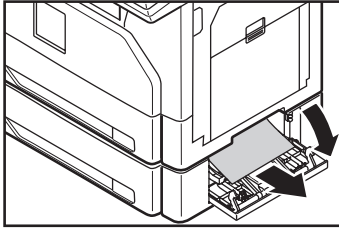
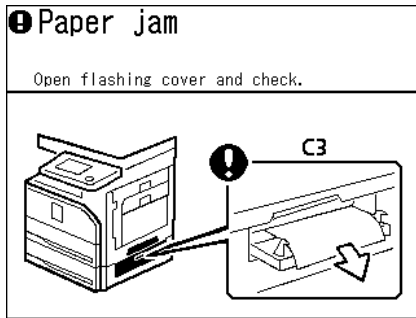

If the third and/or third and fourth cassette is attached, corresponding image will be displayed.

Clearing paper jams in the optional 2-bin tray

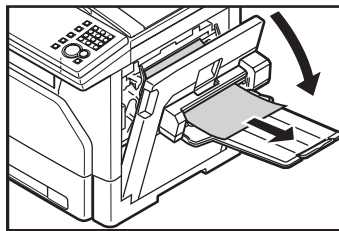
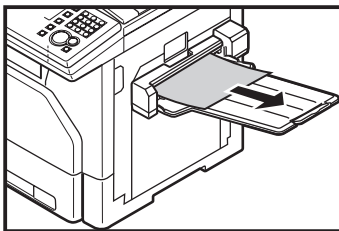
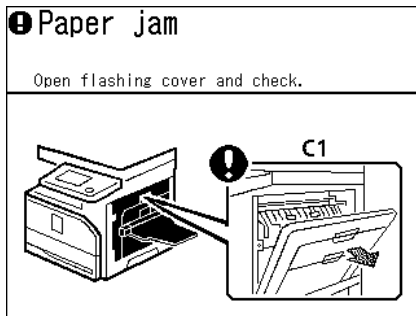

If an error occurs

If an error occurs, the information lamp will illuminate and you will hear an audible beep. Check the message on the display or on the printed message, and clear the error. Some errors may not initiate a message on the screen and you may have to press <Mode> to display the message.

1 Check the message on the display or on the printed message.

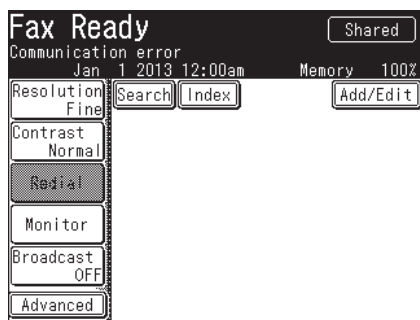

If you do not see a message on the display, press <Mode> to locate the message.

2 Press <Stop> to turn off the information lamp.

With some errors the information lamp will not turn off after you press <Stop>. In this case, clear the error by following the instructions on the display.

3 Follow the message and clear the error.

NOTE

- Errors you can clear by pressing <Stop> include communication errors and memory over flows.
- When a paper cassette is empty, a paper or document has jammed, the toner is empty or a cover has been left open, you cannot clear the error by simply pressing <Stop>. In these cases, clear the error following the displayed instructions. When the error has been cleared the lamp will turn off.
- To clear paper or document jams, see “Clearing paper jams” (page 42) or “Clearing document jams” (page 40).
- For details on error messages, see chapter 4, “Error message” in the Administrator’s Guide.
- For details on communication errors, see chapter 8, “Communication errors” in “Error messages” in the Scanner and Fax Guide.

Troubleshooting

Troubleshooting checklist

CAUTION

If you detect odd sounds, smoke or odor emitting from your machine, unplug the power cord immediately and contact your local technical representative. Do not attempt to disassemble or repair the machine yourself.

IMPORTANT

Attempting to repair the machine yourself may void the limited warranty.

Troubles	Check items	Solutions
The machine does not operate.	Is the power cable firmly inserted?	Insert the power cable firmly into the power plug.
	In the power switch on?	Turn both the primary and secondary power switches on.
The display shows nothing.	Is the machine in energy save mode?	When the <Energy Save> button illuminates, the machine is in energy save mode. Press <Energy Save> to release the mode and to return the machine to the ready screen.
The paper does not come out.	Is paper loaded?	Load the paper into the cassette or bypass tray.
	Is paper jammed?	Check the message on the display and clear the paper jam.
The paper jams frequently.	Is the paper loaded properly?	Load the paper properly. Set the paper guides so that they fit the paper. Set the paper size. For details, see “Setup the paper size” (page 7 and page 9).
	Is the cassette loaded correctly?	Make sure that the cassette is pushed all way in.
	Does the paper meet the specification of the machine?	Use paper that meets the specification for the machine. See chapter 5, “Acceptable paper” in “Specifications” in the Administrator’s Guide.
The document does not come out.	Does the document meet the specification of the machine?	Check chapter 5, “Acceptable documents” in “Specifications” in the Administrator’s Guide.
	Is the document jammed?	Check the message on the display and clear the document jam.
The document jams frequently.	Does the document meet the specification of the machine?	Use documents that meet the specification for the machine. See chapter 5, “Acceptable documents” in “Specifications” in the Administrator’s Guide.
	Is the document guide misaligned?	When you load the document in automatic document feeder, align the document guide with the document.
	Are there any pieces of paper left in the automatic document feeder?	Open the ADF cover and check to see if there are residual pieces of paper caught in the feed rollers.

Troubles	Check items	Solutions
The document jams frequently.	Are the rollers dirty?	Clean the rollers. For details, see chapter 3, “Cleaning the scanning area” in “Cleaning” in the Administrator’s Guide.

For other problems, review the following PDF manuals:

Troubles	References
Image quality is poor.	Chapter 4, “Error messages” and “Troubleshooting” in the Administrator’s Guide
A message is displayed on the display.	
Cannot connect to the network.	
A communication error has occurred.	Chapter 8, “Error messages” and “Troubleshooting” in the Scanner and Fax Guide
Cannot send or receive fax.	
Cannot install the printer drivers.	Chapter 6, “Troubleshooting” in the Printer Guide
Cannot print.	
Cannot use Message Board.	Chapter 6, “Troubleshooting” in the Message Board Guide

If you cannot solve the problem

If you have a problem with your machine that you cannot solve with the information provided in these manuals, contact your local technical representative.

When you contact your local technical representative, make sure you have the following information ready;

- Product name: bizhub 25e
- Serial number (located on the label affixed to the left side of the machine)
- Details on the problem
- Steps you have taken to try to resolve the problem and the results of those efforts

Regulatory information

Customer information

United States of America

The bizhub 25e hereafter referred to as “product”, complies with Part 68 of the FCC rules and the requirements adopted by the ACTA. On the rear panel of the product is a label that contains, among other information, a product identifier in the format US:AAAEQ##TXXXX. If required, this number must be provided to the telephone company.

The REN is used to determine the number of devices that may be connected to a telephone line. Excessive RENs on a telephone line may result in the devices not ringing in response to an incoming call. In most, but not all areas, the sum of RENs should not exceed five (5.0). To be certain of the number of devices that may be connected to a line, as determined by the total RENs, contact the local telephone company. The REN for this product is part of the product identifier that has the format US:AAAEQ##TXXXX. The digits represented by ## are the REN without a decimal point (e.g., 23 is a REN of 2.3). The product is designed for use on standard-device telephone lines. The product connects to the telephone line with a standard line called the USOC RJ-11C.

Any plug and jack used to connect the product to the wiring and telephone network of the premises must comply with the applicable Part 68 of the FCC rules and the requirements adopted by the ACTA. A compliant telephone cord and modular plug is provided with this product. It is designed to be connected to a compatible modular jack that is also compliant. See installation instructions for details.

If the product causes harm to the telephone network, the telephone company will notify you in advance that temporary discontinuance of service may be required. If advance notice isn't practical, the telephone company will notify you as soon as possible and may advise you of your right to file a complaint with the FCC if you believe it is necessary. The telephone company may make changes in its facilities, equipment, operations or procedures that could affect the operation of the product. If this happens, the telephone company will provide advance notice in order for you to make necessary modifications to maintain uninterrupted service.

If trouble is experienced with the product, see operating instructions for details. For further repair or warranty information, please contact our Customer Service. If the product is causing harm to the telephone network, the telephone company may request that you disconnect the product until the problem is resolved.

Connection to party line service is subject to state tariffs. Contact the state public utility commission, public service commission, or corporation commission for information.

If your home has specially wired alarm equipment connected to the telephone line, ensure the installation of the product does not disable your alarm equipment. If you have questions about what will disable alarm equipment, consult your telephone company or a qualified installer.

When programming emergency numbers and/or making test calls to emergency numbers:

- 1) Remain on the line and briefly explain to the dispatcher the reason for the call.
- 2) Perform such activities in the off-peak hours, such as early morning or late evenings.

To protect the product against power surges, we recommend the use of a power protection device (Surge arrestor).

The Telephone Consumer Protection Act of 1991 makes it unlawful for any person to use a computer or other electronic device, including FAX machines, to send any message unless such message clearly contains in a margin at the top or bottom of each transmitted page or on the first page of the transmission, the date and time it is sent and an identification of the receiving business or other entity, or other individual sending the message and the

telephone number of the sending machine or such business, other entity, or individual. (The telephone number provided may not be a 900 number or any other number for which charges exceed local or long-distance transmission charges.)

For instructions on programming this information into the product, see Chapter 7, “Initial setup (User Install)” in the Scanner and Fax Guide.

FCC Part 15

NOTE: This equipment has been tested and found to comply with the limits for a Class B digital device, pursuant to part 15 of the FCC Rules. These limits are designed to provide reasonable protection against harmful interference in a residential installation. This equipment generates, uses and can radiate radio frequency energy and, if not installed and used in accordance with the instructions, may cause harmful interference to radio communications. However, there is no guarantee that interference will not occur in a particular installation. If this equipment does cause harmful interference to radio or television reception, which can be determined by turning the equipment off and on, the user is encouraged to try to correct the interference by one or more of the following measures:

- Reorient or relocate the receiving antenna.
- Increase the separation between the equipment and receiver.
- Connect the equipment into an outlet on a circuit different from that to which the receiver is connected.
- Consult the dealer or an experienced radio/TV technician for help.

FCC CAUTION

Changes or modifications not expressly approved by the party responsible for compliance could void the user’s authority to operate the equipment.

Some connected cables with ferrite core must be used for RF interference suppression. See “Installation Guide” for installation.

Canada

NOTICE:

This product meets the applicable Industry Canada technical specifications.

Le présent matériel est conforme aux spécifications techniques applicables d’Industrie Canada.

NOTICE:

The Ringer Equivalence Number (REN) is an indication of the maximum number of devices allowed to be connected to a telephone interface. The termination of an interface may consist of any combination of devices subject only to the requirement that the sum of the RENs of all the devices not exceed five.

L’indice d’équivalence de la sonnerie (IES) sert à indiquer le nombre maximal de terminaux qui peuvent être raccordés à une interface téléphonique. La terminaison d’une interface peut consister en une combinaison quelconque de dispositifs, à la seule condition que la somme d’indices d’équivalence de la sonnerie de tous les dispositifs n’excède pas cinq.

Canadian ICES-003

CAN ICES-3 (B)/NMB-3(B)

How to read PDF manuals

The following manuals are included on the CD and can be viewed on your computer.

- Administrator's Guide
- Copier Guide
- Scanner and Fax Guide
- Printer Guide
- Message Board Guide

1 Insert the installation disk into the CD drive of the computer.

- The installer will start automatically.
- If the installation screen is not displayed, double-click the "InstMenu.exe" file on the disk.
- When the "User Account Control" screen is displayed, enter an administrator password or provide confirmation.

2 Click [Manual].

Select the language if needed.

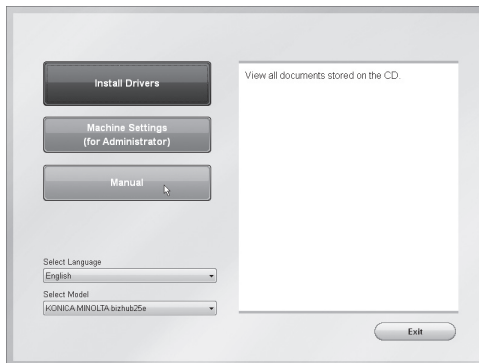

3 Click on the manual you would like to view.

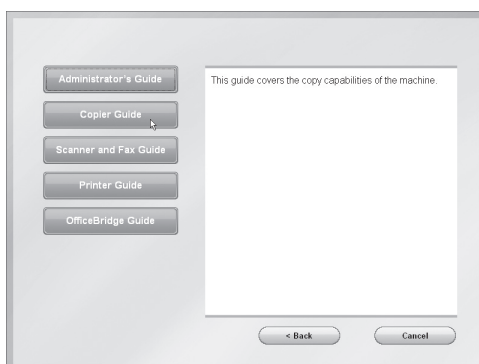

NOTE

In order to access or print PDF manuals your computer needs to have Adobe Acrobat Reader installed. You can download it for free from the Adobe website - www.adobe.com.

Consumables and options

■ Consumables

Consumables for this product include the following:

To order consumables, please contact your local technical representative.

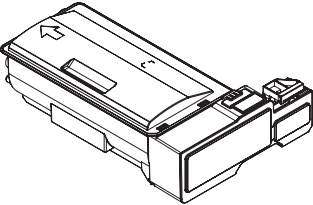
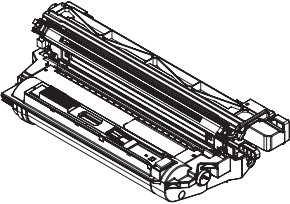
Items	Description
Toner cartridge 	Please order a new toner cartridge when the “The toner is almost empty” message is displayed.
Drum cartridge 	Please order a new drum cartridge when the “Drum life nearing end” message is displayed.
Stamp	If the stamp ink becomes faint, replace the stamp.

■ Options

The following items can be installed on your machine to increase functionality and performance. For details, please contact your local technical representative.

Items	Description
500-sheet paper cassette	You can attach an additional paper cassette to enable increased paper storage or to hold a variety of paper sizes/types.
2-bin tray	You can sort the output to a second tray.
Mechanical counter	This counts the number of printed pages.
PostScript Enabler	This enables the printing of PostScript files.
Barcode Font Enabler	This enables the printing of barcode and OCR fonts.
PostScript/Barcode Font Enabler	This enables printing from Mac OS, as well as the printing of barcode and OCR fonts
PostScript Memory	This is an option for the PostScript Enabler. This enables the printing of PDF files including JPEG2000 images or large size files.
Confirmation stamp	You can stamp a document that has been scanned.

Index

C

Clearing jams	
Document jams.....	40
Paper jams.....	42
Consumables	51
Copy	14

D

Drum cartridge	
Consumable.....	51
Replacement.....	39

E

Energy save key	5
Error	45

F

Fax	
Basic transmission.....	22
Cancel transmission	25
PC-Fax	26

I

Information lamp	5
------------------------	---

M

Manuals	
About the manuals.....	1
How to read PDF manuals	50
Menu screen	13
Message Board	32

N

Network connector	4
-------------------------	---

O

Options	51
---------------	----

P

Paper size setting	
Bypass tray.....	9
Cassette	7
PC-Fax	26
Print	
Basic operation.....	28
Cancel a print job.....	30

R

Ready screens.....	13
Registering destinations	
e-mail and fax destination.....	34
Folder or FTP shortcut	36
Regulatory information.....	48
Reset key	5

S

Scan	
Basic operation.....	16
Color scan	21
Entering a file name	20
Selecting the file format	21

T

Toner cartridge	
Consumable.....	51
Replacement.....	38

U

USB port	4
USB to print	31



KONICA MINOLTA

© 2013 KONICA MINOLTA BUSINESS
SOLUTION U.S.A., INC.

Printed in China

Part Number: KMX-xxxxx-60

DD1-90320-60