

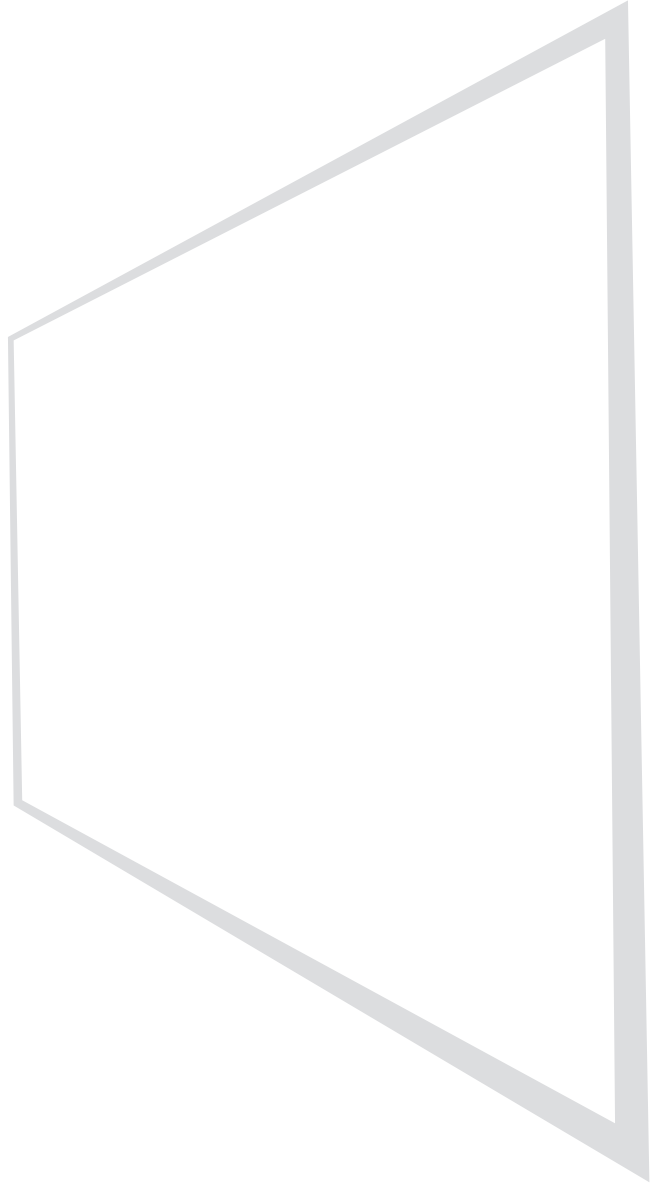

KONICA MINOLTA

**bizhub 5021i/4221i**  
**QUICK GUIDE**



Giving Shape to Ideas



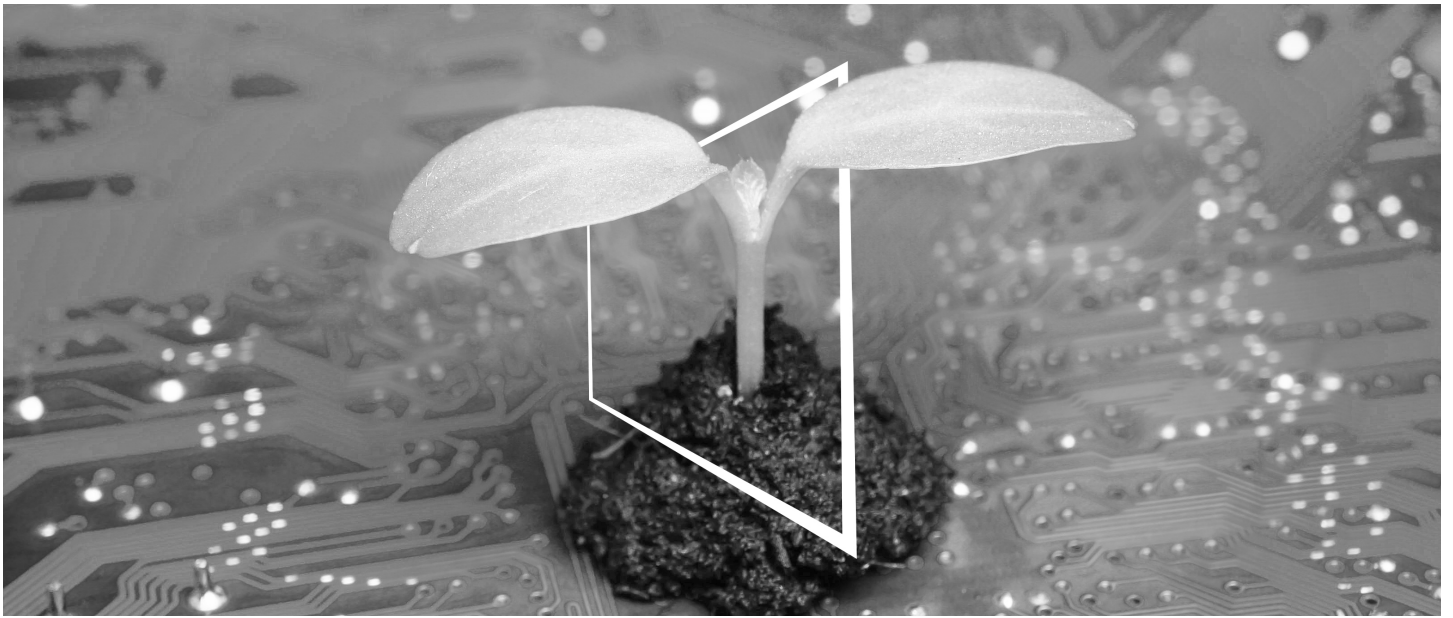

# DIGITAL RESOURCES HUB

## SUSTAINABLE AND ALWAYS UP-TO-DATE!

Our pool of digital resources allows you to make your operations more sustainable and efficient. Access all latest materials and training resources around your system whilst contributing to a more sustainable environment. No need for extensive search and without having to print anything on paper.

### **Latest information at the click of a button** Download Center

Download printer drivers, utilities, user guides etc. all from one place — with the assurance that it is the most up-to-date information.

Visit: <https://konicaminolta.eu/download-centre>



### **Step-by-step guidance for your system** iTraining

iTraining provides an online product introduction that uses clear video sequences with detailed explanations of all the important functions of your system. This step-by-step guidance makes getting to know your system easy.

Visit: <https://itraining.konicaminolta.eu>







# Table of contents

## 1 Before using this machine

<b>1.1</b>	<b>Introduction to User's Guide</b> .....	<b>1-3</b>
	General Safety Information .....	1-3
	Setup Guide .....	1-3
	Quick Guide .....	1-3
	User's Guide .....	1-3
<b>1.2</b>	<b>Symbols and notations used in this manual</b> .....	<b>1-4</b>
<b>1.3</b>	<b>Note</b> .....	<b>1-4</b>

## 2 General information

<b>2.1</b>	<b>Control Panel overview</b> .....	<b>2-3</b>
2.1.1	bizhub 4221i.....	2-3
	Touchscreen LCD overview .....	2-4
2.1.2	bizhub 5021i.....	2-7
	Touchscreen LCD overview .....	2-8
<b>2.2</b>	<b>How to navigate the touchscreen LCD</b> .....	<b>2-9</b>
<b>2.3</b>	<b>Access KONICA MINOLTA Utilities (Windows)</b> .....	<b>2-10</b>
	Uninstall the software (Windows).....	2-10
<b>2.4</b>	<b>Initial setup</b> .....	<b>2-11</b>
	Set the date and time.....	2-11
	Adjust the machine's volume.....	2-11

## 3 Paper handling

<b>3.1</b>	<b>Load paper</b> .....	<b>3-3</b>
3.1.1	Load paper in the paper tray .....	3-3
	Change machine settings to print on letterhead or preprinted paper using the paper tray .....	3-5
3.1.2	Load paper in the multi-purpose tray (MP tray).....	3-6
	Change machine settings to print on letterhead or preprinted paper using the MP tray .....	3-8
3.1.3	Change the Check Paper setting.....	3-8
<b>3.2</b>	<b>Change the Paper Size and Paper Type</b> .....	<b>3-9</b>
<b>3.3</b>	<b>Using special paper</b> .....	<b>3-10</b>

## 4 Print

<b>4.1</b>	<b>Print from your computer</b> .....	<b>4-3</b>
4.1.1	Print a document.....	4-3
4.1.2	Load and print labels using the MP tray .....	4-3
4.1.3	Load and print envelopes using the MP tray .....	4-5

## 5 Copy

<b>5.1</b>	<b>Copy a document</b> .....	<b>5-3</b>
	bizhub 4221i.....	5-3
	bizhub 5021i.....	5-5
<b>5.2</b>	<b>Copy settings</b> .....	<b>5-7</b>
5.2.1	Copy options.....	5-7
	bizhub 4221i.....	5-7
	bizhub 5021i.....	5-8
5.2.2	Copy on both sides of the paper (2-sided) .....	5-10
5.2.3	Copy an ID card .....	5-11
	bizhub 4221i.....	5-12
	bizhub 5021i.....	5-13

<b>6</b>	<b>Scan</b>	
6.1	<b>Scan from your computer</b>	<b>6-3</b>
6.1.1	Scan using iPrint&Scan	6-3
6.2	<b>Scan using the scan button on your machine</b>	<b>6-4</b>
6.2.1	Save scanned data to a folder as a PDF file	6-4
<b>7</b>	<b>Fax</b>	
7.1	<b>Before faxing</b>	<b>7-3</b>
7.1.1	Set your Station ID	7-3
7.1.2	Set telephone line compatibility for interference and VoIP systems	7-3
	bizhub 4221i	7-3
	bizhub 5021i	7-4
7.1.3	Receive modes	7-4
	Fax Only mode	7-4
	Fax/Tel mode	7-4
	Manual mode	7-4
	External TAD mode	7-4
7.1.4	Choose the correct receive mode	7-5
7.1.5	Set the F/T Ring Time (Fast double-ring)	7-5
7.1.6	Set the number of rings before the machine answers (Ring Delay)	7-6
7.2	<b>Store fax numbers</b>	<b>7-7</b>
7.2.1	Store address book numbers	7-7
7.2.2	Change or delete address book names or numbers	7-7
7.3	<b>Send and receive a fax using your machine</b>	<b>7-8</b>
7.3.1	Send a fax	7-8
7.4	<b>Fax using your computer (PC-FAX)</b>	<b>7-10</b>
7.4.1	Send a fax using PC-FAX (Windows)	7-10
7.4.2	Receive faxes on your computer (Windows)	7-11
	Receive faxes Using PC-FAX Receive	7-11
<b>8</b>	<b>Troubleshooting</b>	
8.1	<b>Error and maintenance messages</b>	<b>8-3</b>
8.2	<b>Telephone and fax problems</b>	<b>8-7</b>
8.3	<b>Printing problems</b>	<b>8-8</b>
8.4	<b>Document and paper jams</b>	<b>8-9</b>
8.4.1	Clear the document jam	8-9
	Document is jammed in the top of the ADF unit	8-9
	Document is jammed under the document cover	8-9
	Remove small scraps of paper jammed in the ADF	8-10
8.4.2	Clear the paper jam	8-10
	Paper is jammed in the MP tray	8-10
	Paper is jammed in the paper tray	8-11
	Paper is jammed in the back of the machine	8-12
	Paper is jammed inside the machine	8-14
	Paper is jammed in the 2-sided tray	8-16
<b>9</b>	<b>Appendix</b>	
9.1	<b>How to enter text on your machine</b>	<b>9-3</b>



**Before using this machine**

---



# 1 Before using this machine

## 1.1 Introduction to User's Guide

### **General Safety Information**

Read this guide first. Please read the Safety Instructions before you set up your machine.

### **Setup Guide**

Follow the instructions for setting up your machine, and installing the drivers and software for the operating system and connection type you are using.

### **Quick Guide**

Learn the basic operations and basic machine maintenance. See troubleshooting tips.

### **User's Guide**

This guide includes the additional contents of the Quick Guide.

In addition to information about the Print operations, useful information is included about using the machine on a network.

## 1.2 Symbols and notations used in this manual

### **WARNING**

- Improper handling can cause serious injury or death.

### **CAUTION**

- Improper handling can cause minor injury or damage to houses and property.

### **NOTICE**

*This symbol indicates a risk that may result in damage to this machine or documents. Follow the instructions to avoid property damage.*



### **Tips**

- This symbol indicates supplemental information of a topic as well as options required to use a function.

<b>Symbols/Notations</b>	<b>Description</b>
✓	This check mark symbol shows a precondition of a procedure.
→	This symbol indicates a supplementary explanation of a procedural instruction.
[ ]	An item enclosed by brackets [ ] indicates a key name on the LCD or computer screen, or the name of a user's guide.
<b>Bold text</b>	This presents a key name, product name, or option name on the control panel.

## 1.3 Note

User's Guide may not be reproduced in part or in full without permission.

KONICA MINOLTA, INC. will not be held liable for any incidents caused by using this printing system or User's Guide.

Information included in User's Guide is subject to change without notice.

---



## 2 General information



## 2 General information

### 2.1 Control Panel overview

#### 2.1.1 bizhub 4221i

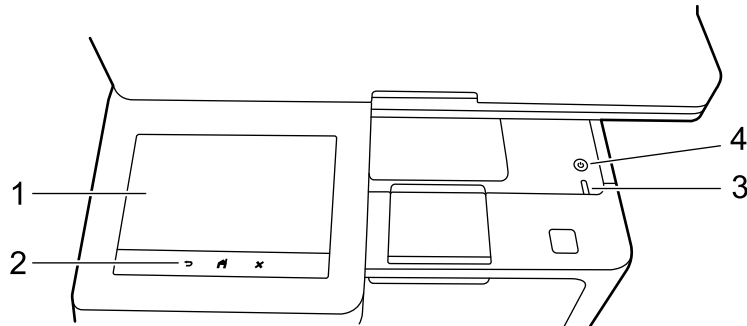

No.	Name	Description
1	Touchscreen Liquid Crystal Display (LCD)	<p>You can select from two types of screens to set as the Main Home screen: Home screens and Shortcuts screens. When a Home screen is displayed, swipe left or right or press ◀ or ▶ to display the other Home screens.</p> <p>The Main Home screen displays the machine's status when the machine is idle. When displayed, this screen indicates that your machine is ready for the next command.</p> <p>If Active Directory Authentication or LDAP Authentication is enabled, the machine's control panel is locked.</p> <p>The Home screens provide access to features, such as Fax, Copy, and Scan.</p>
2	Touchpanel	<ul style="list-style-type: none"> <li>◀ (Back): Press to go back to the previous menu.</li> <li>🏠 (Home): Press to return to the Main Home screen.</li> <li>✖ (Cancel): Press to cancel an operation.</li> </ul>
3	LED Power Indicator	The LED lights up depending on the machine's power status.
4	⏻ Power On/Off	<p>Turn the machine on by pressing ⏻.</p> <p>Turn the machine off by holding down ⏻. The LCD displays [Shutting Down] for a few seconds before the machine turns off. If you have an external telephone or TAD connected, it is still available.</p>

### Touchscreen LCD overview

Home screen: Screen 1

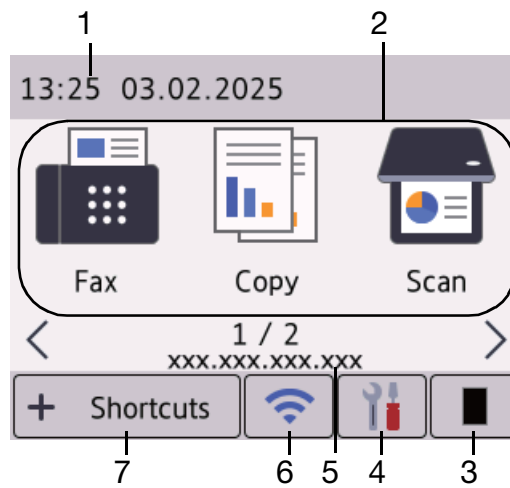

Home screen: Screen 2

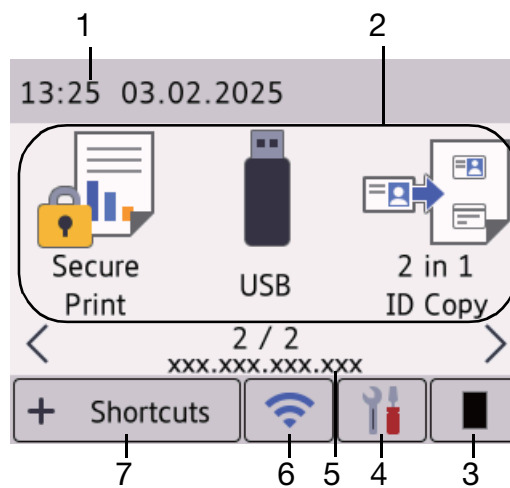









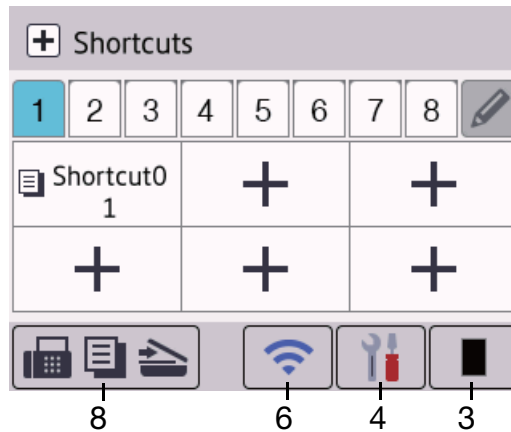

## Shortcuts screen

Create Shortcuts for frequently used operations, such as sending a fax, making a copy, and scanning.

 **Tips**

Eight Shortcuts tabs are available with six Shortcuts on each Shortcuts tab. A total of 48 Shortcuts are available.



No.	Name	Description
1	Date & Time	Displays the date and time set on the machine.
2	Function Icons	<ul style="list-style-type: none"> <li>[Fax]: Press to access Fax mode.</li> <li>[Copy]: Press to access Copy mode.</li> <li>[Scan]: Press to access Scan mode.</li> <li>[Secure Print]: Press to access the [Secure Print] option.</li> <li>[USB]: Press to access the USB menu and select [Scan to USB] or [Direct Print] options.</li> <li>[2 in 1 ID Copy]: Press to access the 2 in 1 ID Copy option.</li> </ul>
3	 (Toner)	Displays the remaining toner life. Press to access the [Toner] menu.
4	 (Settings)	Press to access the [Settings] menu. If the Setting Lock function has been turned on, a lock  icon appears on the LCD. You must unlock the machine to change the settings.
5	IP Address	If the IP Address setting in the Display Information menu has been turned on, your machine's IP Address appears on the Home screens.
6	 (Wireless Status)	Press to configure the wireless settings. If you are using a wireless connection, a four-level indicator displays the current wireless signal strength.   Wireless LAN Disabled
	 (Wired LAN Status)	Press to configure the Wired LAN settings. The icon displays the current wired network status.
7	 [Shortcuts]	Press to access the [Shortcuts] screen.
8	 (Home screen)	Press to access the Home screens.

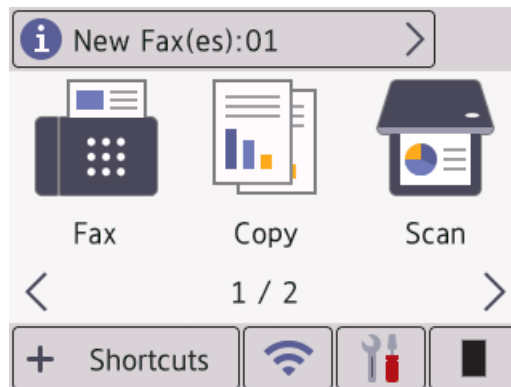

## New Fax

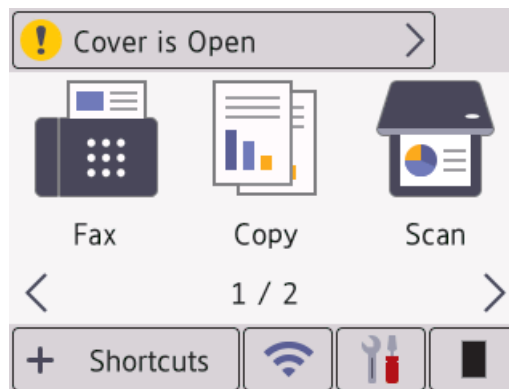

When [Fax Preview] is set to [On], the number of new faxes you received into the memory appears at the top of the screen.

## Warning Icon



The warning icon  appears when there is an error or maintenance message. Press the message area to view it, and then press  to return to the Main Home screen.



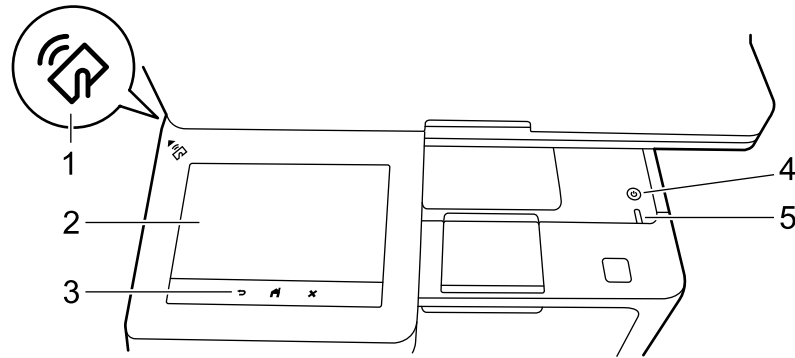





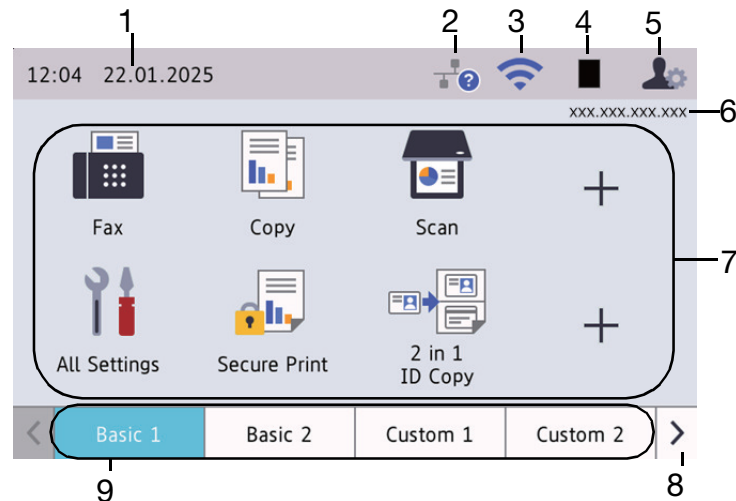

## 2.1.2 bizhub 5021i



No.	Name	Description
1	ID Card Reader	Use card authentication, if applicable, by touching your Integrated Circuit Card (IC Card) to the reader on the machine.
2	Touchscreen Liquid Crystal Display (LCD)	Access menus and options by pressing them on the touchscreen. Your machine has eight tabbed screens (referred to as Home screens). Each Home screen can hold up to eight icons which can be used for functions, machine settings and shortcuts. A total of 64 icons can be placed on the Home screens as needed. The Main Home screen can be selected from the Home screens. Use the [Admin Settings] menu to group names on the tabs and rearrange the icons.
3	Touchpanel	<ul style="list-style-type: none"> <li>⏪ (Back): Press to go back to the previous menu.</li> <li>🏠 (Home): Press to return to the Main Home screen.</li> <li>❌ (Cancel): Press to cancel an operation.</li> </ul>
4	⏻ Power On/Off	Turn the machine on by pressing ⏻. Turn the machine off by holding down ⏻. The LCD displays [Shutting Down] for a few seconds before the machine turns off. If you have an external telephone or TAD connected, it is still available.
5	LED Power Indicator	The LED lights up depending on the machine's power status.

## Touchscreen LCD overview



No.	Name	Description
1	Date & Time	Displays the date and time set on the machine. This area is also used to display error or maintenance messages.
2	 (Wired LAN Status)	Press to configure the Wired LAN settings. The icon displays the current wired network status. <ul style="list-style-type: none"> <li> Wired LAN Disabled (Grey)</li> <li> Wired LAN Enabled (Blue)</li> <li> No cable connection</li> </ul>
3	 (Wireless Status)	Press to configure the wireless settings. If you are using a wireless connection, a four-level indicator displays the current wireless signal strength. <div style="text-align: center;">  <p>0                      Max</p> </div>  Wireless LAN Disabled
4	 (Toner)	Displays the remaining toner life. Press to access the [Toner] menu.
5	 (Admin Settings)	Press to access the [Admin Settings] menu. If required, enter the password you use to manage this machine in Web Based Management, and then press [OK].
6	IP Address	If the IP Address setting in the Display Information menu has been turned on, your machine's IP Address appears on the Home screens.
7	Function Icons, Setting Icons, and Shortcut Icons	The following descriptions explain basic icons and features. <ul style="list-style-type: none"> <li>[All Settings]: Press to access the machine's settings menu.</li> <li>[Fax]: Press to access Fax mode.</li> <li>[Copy]: Press to access Copy mode.</li> <li>[Scan]: Press to access Scan mode.</li> <li>[Secure Print]: Press to access the [Secure Print] option.</li> <li>[USB]: Press to access the USB menu and select [Scan to USB] or [Direct Print] options.</li> <li>[2 in 1 ID Copy]: Press to access the 2 in 1 ID Copy option.</li> <li>[Eco Mode]: Press to access the [Eco Mode] menu.</li> <li> (Shortcuts): Press to create Shortcuts for frequently-used operations, such as sending a fax, copying and scanning.</li> </ul>
8	Tabs Scroll Buttons	Press to display the Home screens.
9	Home Tabs	Press to display the screen for the Home.

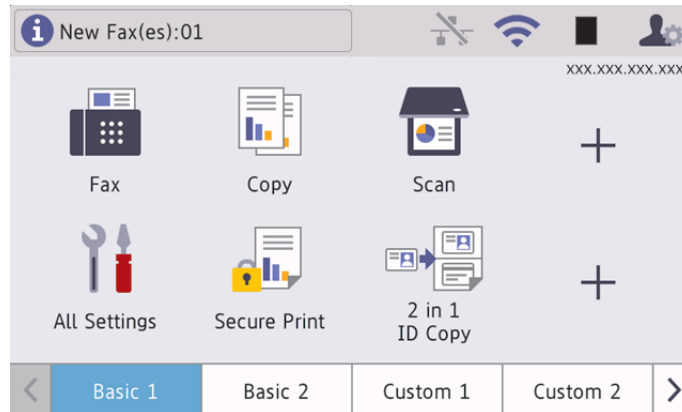

## New Fax





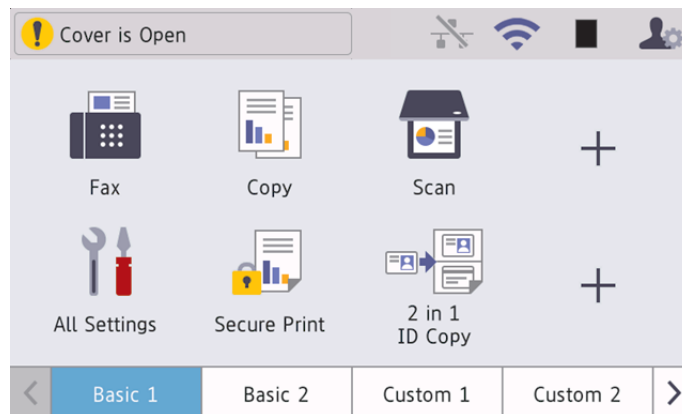

When [Fax Preview] is set to [On], the number of new faxes you received into the memory appears at the top of the screen.

## Warning Icon



The warning icon  appears when there is an error or maintenance message. Press the message area to view it, and then press  to return to the Main Home screen.

## 2.2 How to navigate the touchscreen LCD

Press your finger on the LCD to operate it. To display and access all the options, swipe left, right, up, and down, or press , , , or  on the LCD to scroll through them.

### NOTICE

*DO NOT press the LCD with a sharp object, such as a pen or stylus. It may damage the machine.*



*DO NOT touch the LCD immediately after plugging in the power cord or turning the machine on. Doing this may cause an error.*

### Tips

- This product uses fonts owned by ARPHIC TECHNOLOGY CO., LTD.

## 2.3 Access KONICA MINOLTA Utilities (Windows)

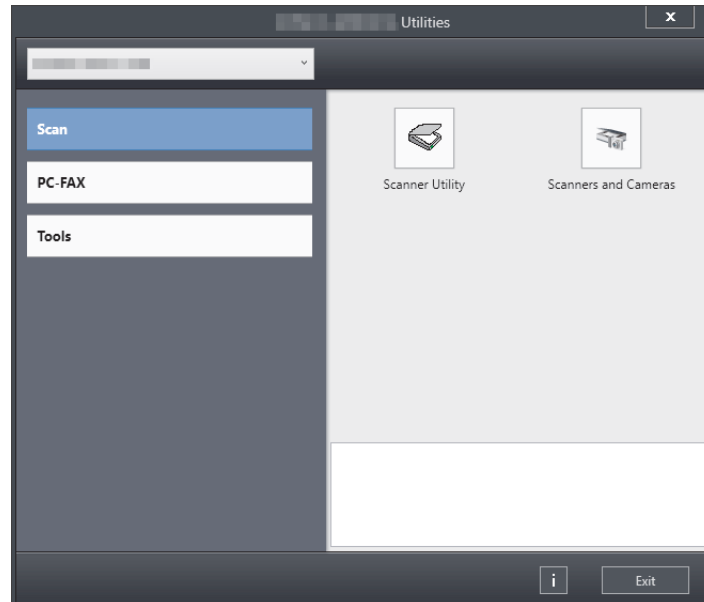

**KONICA MINOLTA Utilities** is an application launcher that offers convenient access to all applications installed on your computer.

- 1 Do one of the following:
  - (Windows 11) Click  > [All apps] > [KONICA MINOLTA] > [KONICA MINOLTA Utilities].
  - (Windows 10) Click  > [KONICA MINOLTA] > [KONICA MINOLTA Utilities].
- 2 Select your machine.







- 3 Choose the option you want.

### Uninstall the software (Windows)



- 1 Do one of the following:
  - (Windows 11) Click  > [All apps] > [KONICA MINOLTA] > [KONICA MINOLTA Utilities].
  - (Windows 10) Click  > [KONICA MINOLTA] > [KONICA MINOLTA Utilities].
- 2 Select your model from the drop-down list (if it is not already selected).
- 3 Click [Tools] in the left navigation bar.
- 4 Click [Uninstall] in the [Tools] section of [KONICA MINOLTA Utilities].  
Follow the instructions in the dialog box to uninstall the software and drivers.

## 2.4 Initial setup

### Set the date and time

- 1 Press  [Settings] > [All Settings] > [Initial Setup] > [Date & Time] > [Date].
  - If your machine displays the [All Settings] menu on the Home screen, skip the [Settings] menu.
- 2 Enter the last two digits of the year using the LCD, and then press [OK].
- 3 Enter the two digits for the month using the LCD, and then press [OK].
- 4 Enter the two digits for the day using the LCD, and then press [OK].
- 5 Press [Clock Type].
- 6 Press [12h Clock] or [24h Clock].
- 7 Press [Time].
- 8 To enter the time, do one of the following:
  - If you selected [12h Clock] as the format in the [Clock Type] setting, enter the time (in 12-hour format) using the LCD.  
Press   to select [AM] or [PM].  
Press [OK].
  - If you selected [24h Clock] as the format in the [Clock Type] setting, enter the time (in 24-hour format) using the LCD.  
Press [OK].  
(For example: enter 19:45 for 7:45 PM.)
- 9 Press .

### Adjust the machine's volume

- 1 Press  [Settings] > [All Settings] > [General Setup] > [Volume].
  - If your machine displays the [All Settings] menu on the Home screen, skip the [Settings] menu.
- 2 Press one of the following options:
  - [Ring]: Adjust the ring volume.
  - [Beep]: Adjust the volume of the beep you hear when you press a button, make a mistake, or after you send or receive a fax.
  - [Speaker]: Adjust the speaker volume.
- 3 Select the [Off], [Low], [Med] or [High] option, and then press the option you want.
- 4 Press .



---



# 3

## Paper handling



## 3 Paper handling

### 3.1 Load paper

#### 3.1.1 Load paper in the paper tray

- ✓ If, when the Check Paper setting is set to On and you pull the paper tray out of the machine, a message appears on the LCD asking if you want to change the paper size and paper type, change these settings, if needed, following the LCD instructions.
- ✓ When you load a different size and type of paper in the tray, you must also change the Paper Size and Paper Type settings on the machine, or on your computer.

- 1 Pull the paper tray completely out of the machine.

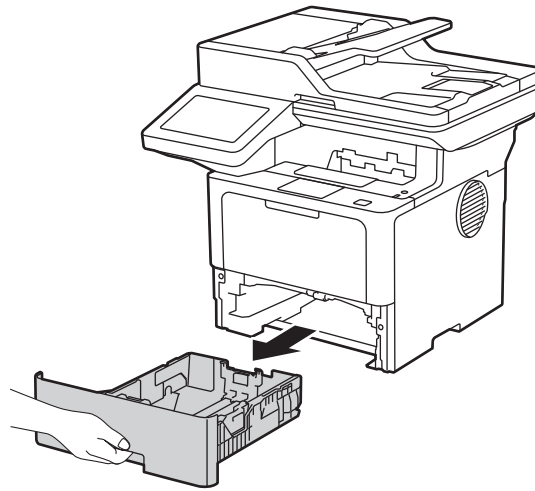

- 2 Press the blue levers to slide the paper guides to fit the paper.

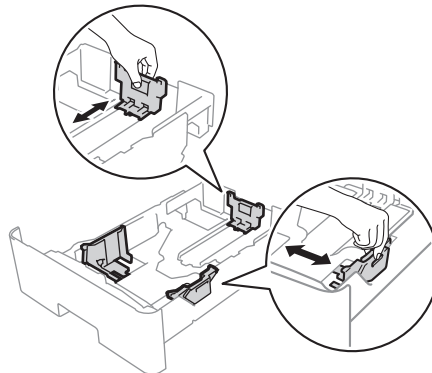

For Legal or Folio size paper, press the release button (1) in the bottom of the paper tray or the release lever (2) in the back of the tray, and then pull out the back of the paper tray. (Legal and Folio size paper are not available in some regions.)

→ For trays with a release button:

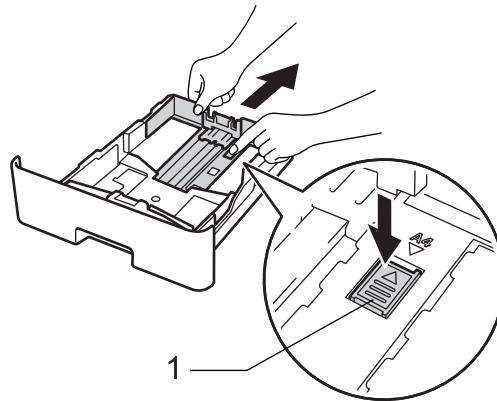

→ For trays with a release lever:

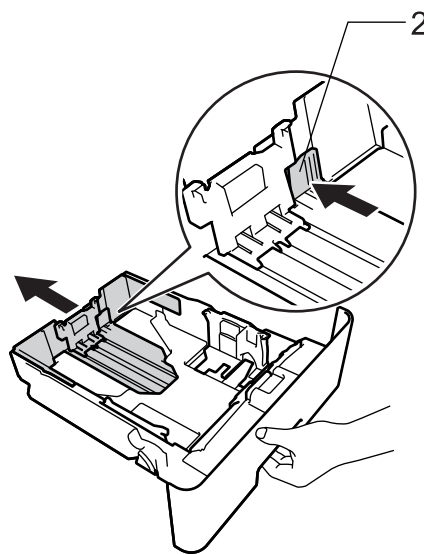

- 3 Fan the stack of paper well.
- 4 Load paper in the paper tray with the printing surface face down.

**NOTICE**

*When you use letterhead or preprinted paper, load the paper in the correct orientation.*

- 5 Make sure the paper is below the maximum paper mark (▼▼▼).  
Overfilling the paper tray will cause paper jams.

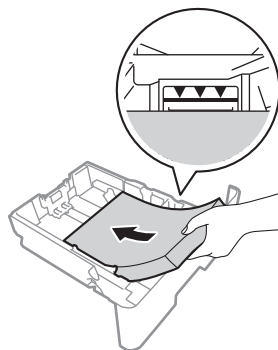

- 6 Slowly push the paper tray completely into the machine.

- 7 Lift the support flap to prevent paper from sliding off the output tray.

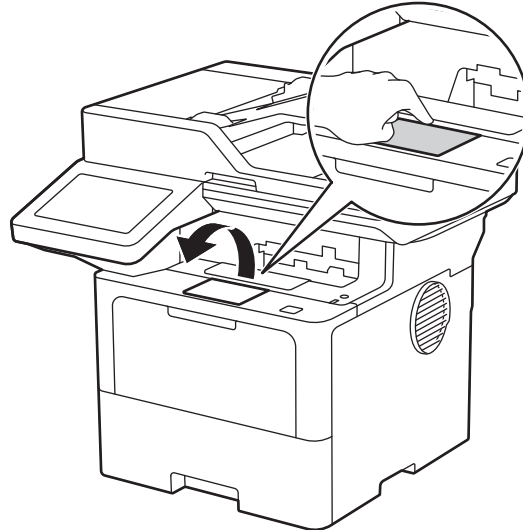

### Change machine settings to print on letterhead or preprinted paper using the paper tray

When you use letterhead or preprinted paper for 2-sided printing, change the machine's settings.

#### NOTICE

*DO NOT load different sizes and types of paper in the paper tray at the same time. Doing this may cause the paper to jam or misfeed.*

*If the print position is misaligned with the letterhead or preprinted objects, the print position is adjustable using the Print Position setting for the paper tray.*

*Some preprinted paper may cause print stains, depending on the printing method and ink type.*

Orientation

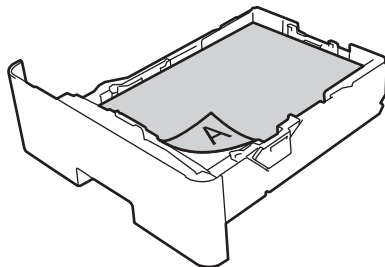

For 1-sided printing

- face down
- top edge towards the front of the paper tray

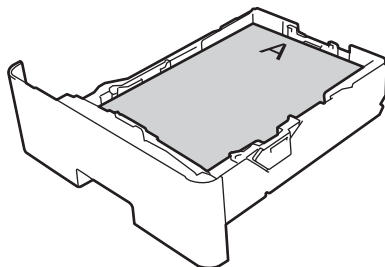

For automatic 2-sided printing (long edge binding)

- face up
- bottom edge towards the front of the paper tray

- 1 Press [Settings] > [All Settings] > [Printer] > [2-sided] > [Single Image] > [2-sided Feed].  
→ If your machine displays the [All Settings] menu on the Home screen, skip the [Settings] menu.
- 2 Press .

### 3.1.2 Load paper in the multi-purpose tray (MP tray)

When you load a different size and type of paper in the tray, you must also change the Paper Size and Paper Type settings on the machine, or on your computer.

Plain Paper / Thin Paper / Thick Paper / Recycled Paper / Bond Paper / Letterhead / Coloured Paper

- 1 Lift the support flap to prevent paper from sliding off the face down output tray.

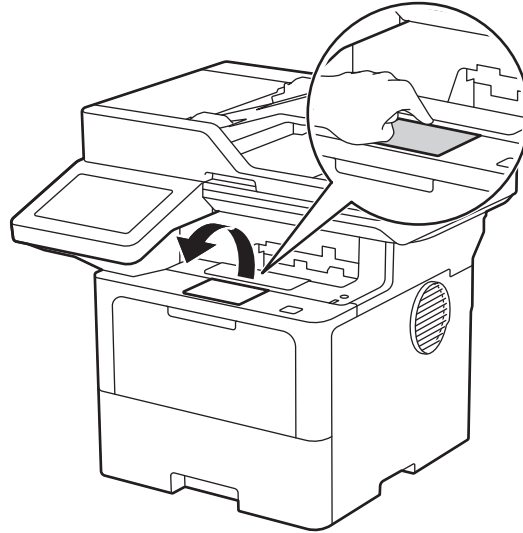

- 2 Open the MP tray and lower it gently.

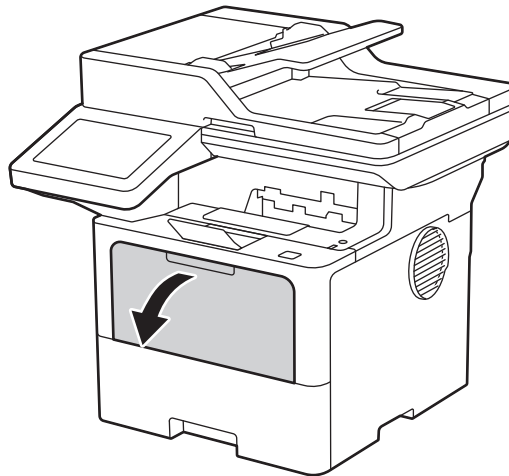

- 3 Extend the MP tray support.

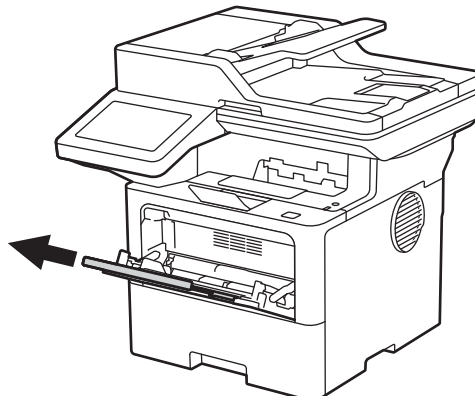

- 4 Slide the MP tray paper guides to fit the width of the paper you are using.

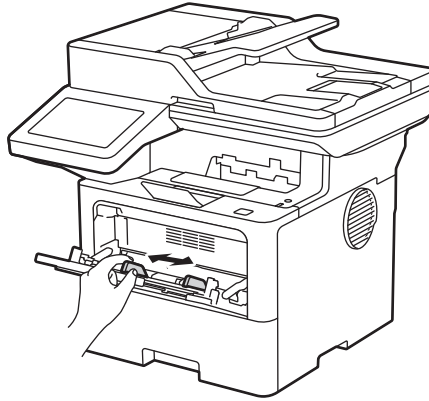

- 5 Load paper with the printing surface face up in the MP tray.
- Make sure the paper is below the maximum paper mark (1).
  - When you use letterhead or preprinted paper, load the paper in the correct orientation.

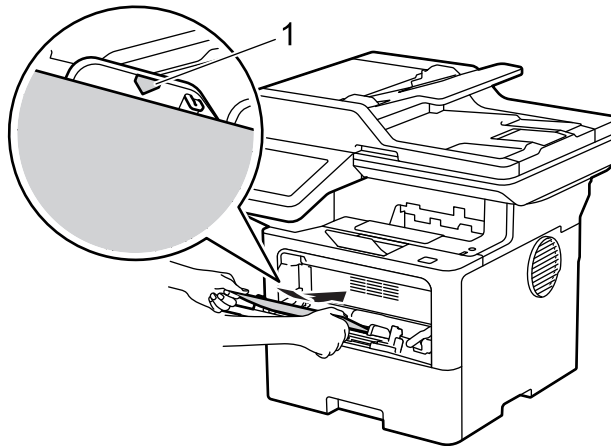

## Change machine settings to print on letterhead or preprinted paper using the MP tray

When you use letterhead or preprinted paper for 2-sided printing, change the machine's settings.

### NOTICE

*DO NOT load different sizes and types of paper in the paper tray at the same time. Doing this may cause the paper to jam or misfeed.*

*If the print position is misaligned with the letterhead or preprinted objects, the print position is adjustable using the Print Position setting for the MP tray.*

*Some preprinted paper may cause print stains, depending on the printing method and ink type.*

Orientation

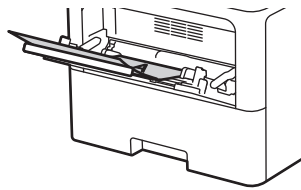

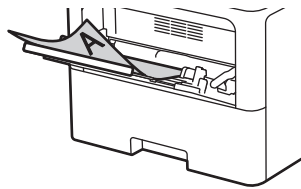

For 1-sided printing

- face up
- top edge first



For automatic 2-sided printing (long edge binding)



- face down
- bottom edge first

- 1 Press  [Settings] > [All Settings] > [Printer] > [2-sided] > [Single Image] > [2-sided Feed].  
→ If your machine displays the [All Settings] menu on the Home screen, skip the [Settings] menu.
- 2 Press .

### 3.1.3 Change the Check Paper setting



When the Check Paper setting is set to On and you pull the paper tray out of the machine, or load paper in the MP tray, a message appears on the LCD asking if you want to change the paper size and paper type.

The default setting is On.

- 1 Press  [Settings] > [All Settings] > [General Setup] > [Tray Setting] > [Check Paper].  
→ If your machine displays the [All Settings] menu on the Home screen, skip the [Settings] menu.
- 2 Press [On] or [Off].
- 3 Press .

## 3.2 Change the Paper Size and Paper Type

When you change the size and type of paper you load in the tray, you must also change the Paper Size and Paper Type settings on the LCD.

- 1 Press  [Settings] > [All Settings] > [General Setup] > [Tray Setting] > [Paper Type].  
→ If your machine displays the [All Settings] menu on the Home screen, skip the [Settings] menu.
- 2 Press the option you want.
- 3 Swipe up or down or press ▲ or ▼ to display the paper type options, and then press the option you want.
- 4 Press .
- 5 Press [Paper Size].
- 6 Press the option you want.
- 7 Swipe up or down or press ▲ or ▼ to display the paper size options, and then press the option you want.
- 8 Press .

### 3.3 Using special paper

Always test paper samples before purchasing them to ensure desirable performance.

- DO NOT use inkjet paper; it may cause a paper jam or damage your machine.
- If you use bond paper, paper with a rough surface, or paper that is wrinkled or creased, the paper may exhibit degraded performance.

Store paper in its original packaging and keep it sealed. Keep the paper flat and away from moisture, direct sunlight, and heat.

#### **NOTICE**

*Some types of paper may not perform well or may cause damage to your machine.*

DO NOT use paper:

- that is highly textured
- that is extremely smooth or shiny
- that is curled or warped
- that is coated or has a chemical finish
- that is damaged, creased, or folded
- that exceeds the recommended weight specification in this guide
- with tabs and staples
- with letterhead using low temperature dyes or thermography
- that is multipart or carbonless
- that is designed for inkjet printing

If you use any of the types of paper listed above, they may damage your machine. This damage is not covered under any warranty or service agreement.

---

**4** Print



## 4 Print

### 4.1 Print from your computer

#### 4.1.1 Print a document

- ✓ For labels, thick paper, and envelopes, set the paper size and paper type in the printer before printing the document.
- 1 From the document that you are trying to print, open the Print dialog.
- 2 If necessary, adjust the settings.
- 3 Print the document.

For details of the function of the printer driver, refer to the Help of the printer driver.

#### 4.1.2 Load and print labels using the MP tray

- ✓ When you print on labels, open the back cover (face up output tray) and use the MP tray.
- ✓ When you load a different size and type of paper in the tray, you must also change the Paper Size and Paper Type settings on the machine, or on your computer.
- 1 Open the machine's back cover (the face up output tray).

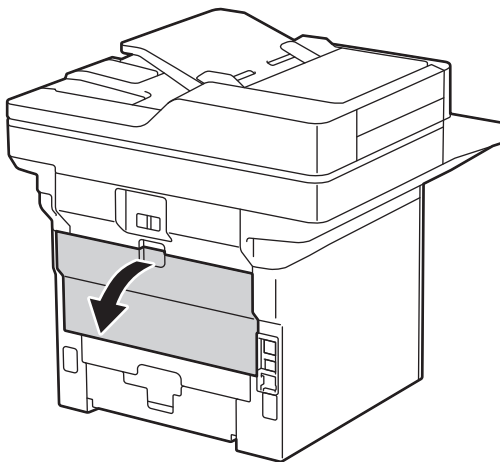

- 2 Open the paper stopper.

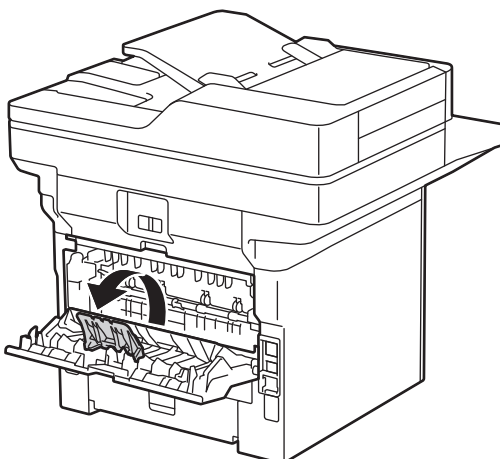

- 3 On the front of the machine, open the MP tray and lower it gently.

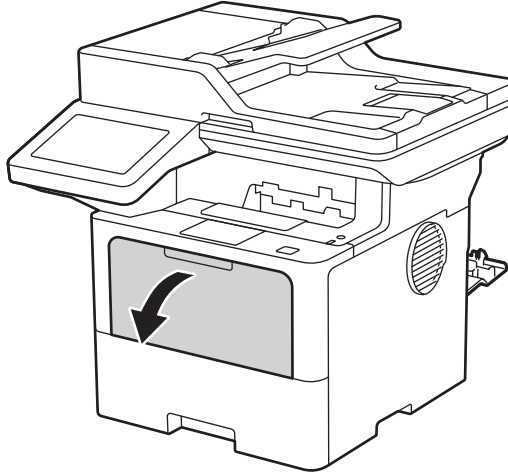

- 4 Extend the MP tray support.

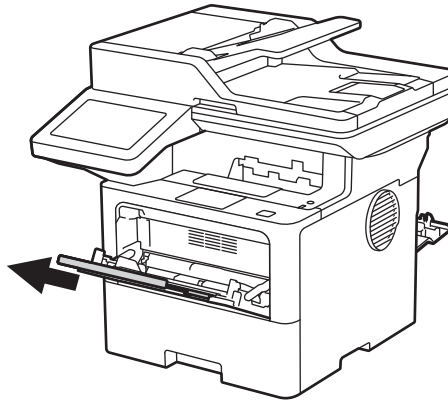

- 5 Slide the MP tray paper guides to fit the width of the labels you are using.

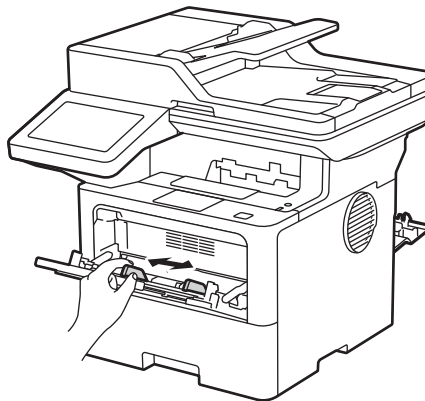

- 6** Load labels with the printing surface face up in the MP tray.  
 → Make sure the labels are below the maximum paper mark (1).

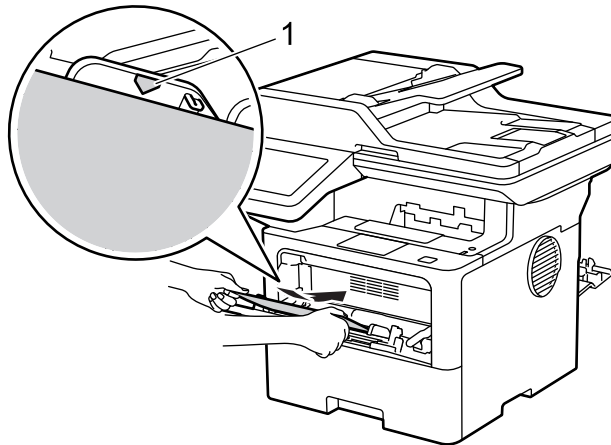

- 7** Change your print preferences in the Print screen.  
**8** Send your print job to the machine.  
**9** When finished, close the back cover (the face up output tray) until it locks in the closed position.  
 → Close the paper stopper, and then close the back cover.

### 4.1.3 Load and print envelopes using the MP tray

- ✓ Before loading, press the corners and sides of the envelopes to make them as flat as possible.

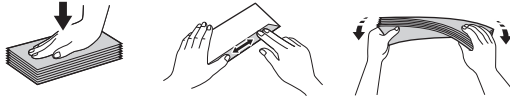

- ✓ When you load a different size and type of paper in the tray, you must also change the Paper Size and Paper Type settings on the machine, or on your computer.

- 1** Open the machine's back cover (the face up output tray).

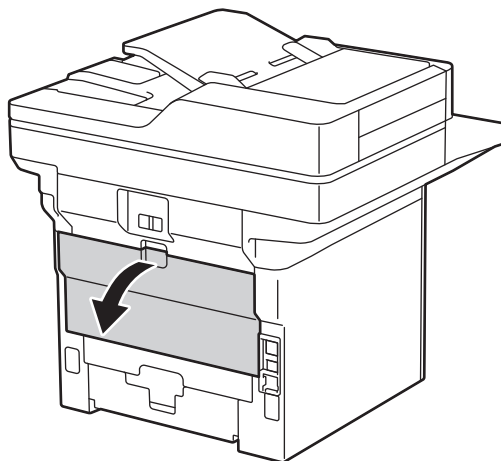

- 2 Open the paper stopper.

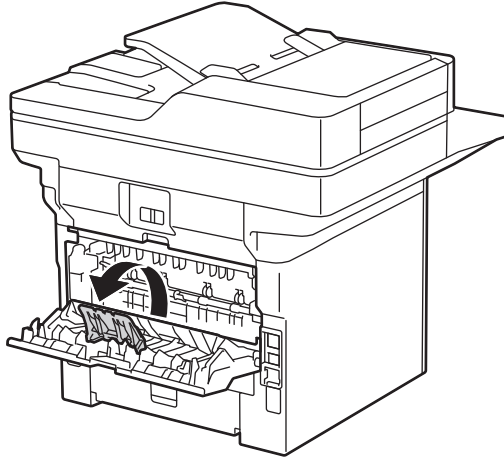

- 3 On the front of the machine, open the MP tray and lower it gently.

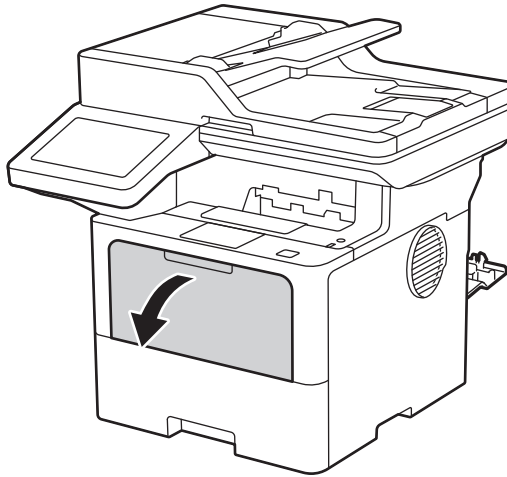

- 4 Extend the MP tray support.

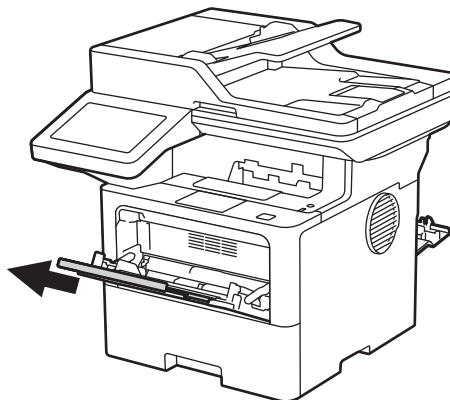

- 5 Slide the MP tray paper guides to fit the width of the envelopes that you are using.

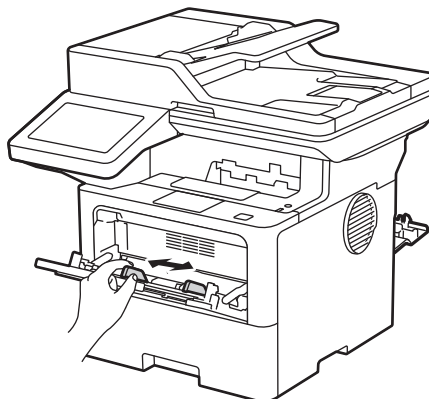

- 6 Load envelopes with the printing surface face up in the MP tray.  
→ Load the envelopes in the MP tray with the printing surface face up. Make sure the envelopes are below the maximum paper mark (1).

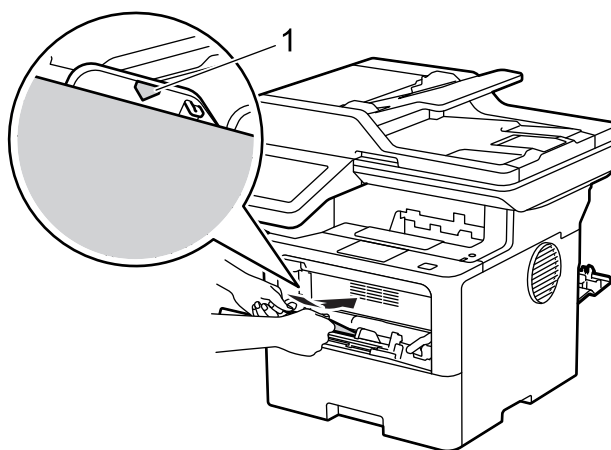

- 7 Change your print preferences in the Print dialog box.  
→ [Paper Size]: [Envelope Com 10] / [Envelope DL] / [Envelope C5] / [Envelope Monarch]  
→ [Paper Type]: [Envelope] / [Env. Thick] / [Env. Thin]
- 8 Send your print job to the machine.
- 9 When finished, close the back cover (the face up output tray) until it locks in the closed position.  
→ Close the paper stopper, and then close the back cover.



---

**5** Copy

---



## 5 Copy

### 5.1 Copy a document

#### bizhub 4221i

- 1 Make sure you have loaded the correct size paper in the paper tray.
- 2 Do one of the following:
  - Place the document face up in the ADF. (If you are copying multiple pages, we recommend using the ADF.)

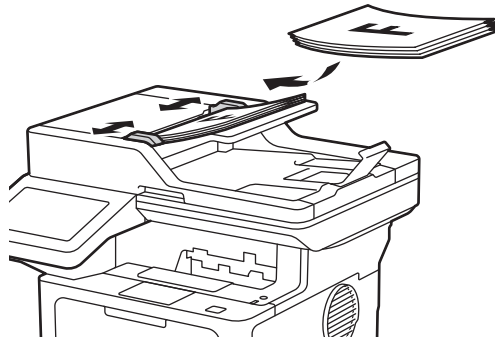

- Place the document face down on the scanner glass.

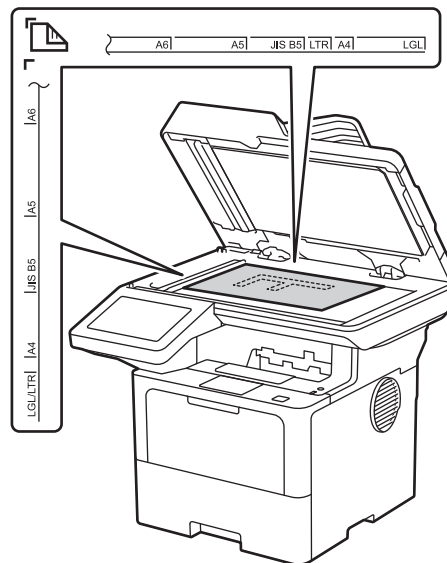

#### **NOTICE**

*For important or fragile documents, use the machine's scanner glass, not the ADF.*

- 3 Press  [Copy].

The LCD displays:

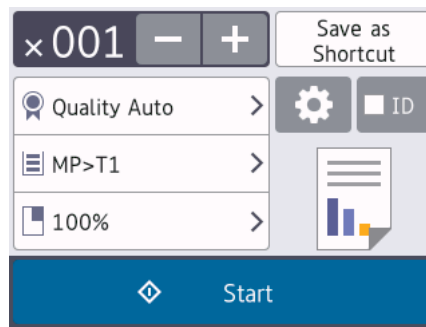

- 4 Change the copy settings, if needed.

- **001** (Number of copies)

Enter the number of copies in one of the following ways:

Press **+** or **-** on the LCD.

Press **001** to display a numeric keypad on the LCD, and then enter the number of copies. Press [OK].

-  [Options]

Press  to change the copy settings for the next copy only.

When finished, press [OK]. (If the [OK] button is displayed.)

After you have finished choosing new options, you can save them by pressing the [Save as Shortcut] button.

- Current setting

Press the following display area to change these settings for the next copy only.

 [Quality]

 [Tray Use]

 [Enlarge/Reduce]

- 5 Press [Start].

- To stop copying, press .

**bizhub 5021i**

- 1 Make sure you have loaded the correct size paper in the paper tray.
- 2 Do one of the following:
  - Place the document face up in the ADF. (If you are copying multiple pages, we recommend using the ADF.)

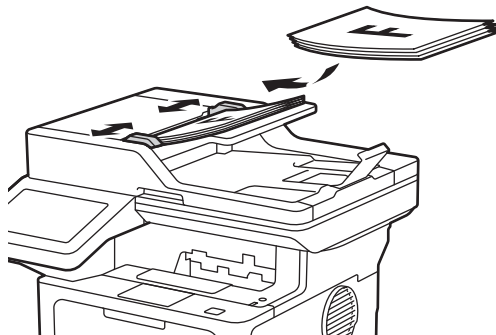

- Place the document face down on the scanner glass.

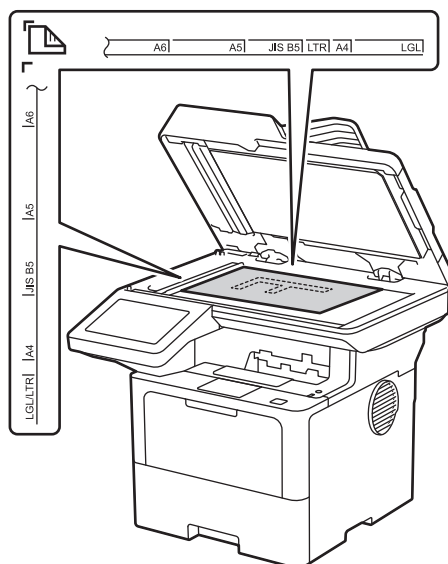
**NOTICE**

For important or fragile documents, use the machine's scanner glass, not the ADF.

- 3 Press  [Copy].

The LCD displays:

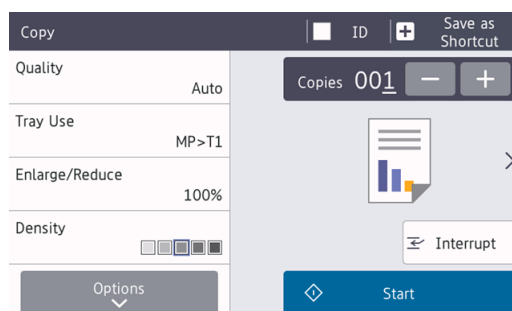

#### 4 Change the copy settings, if needed.

→ **001** (Number of copies)

Enter the number of copies in one of the following ways:

Press **+** or **-** on the LCD.

Press **001** to display a numeric keypad on the LCD, and then enter the number of copies. Press [OK].

→ [Options]

Press  to change the copy settings for the next copy only.

When finished, press [OK]. (If the [OK] button is displayed.)

After you have finished choosing new options, you can save them by pressing the [Save as Shortcut] button.

→ Quick Copy

Press **>** to access the preset copy settings.

→ Current setting

Press the following display area to change these settings for the next copy only.

[Quality]

[Tray Use]

[Enlarge/Reduce]

[Density]

#### 5 Press [Start].

→ To stop copying, press .

## 5.2 Copy settings

### 5.2.1 Copy options

#### bizhub 4221i

To change the Copy settings, press  [Options].

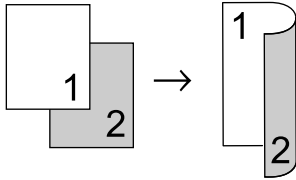
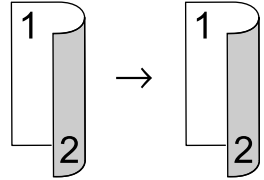
Menu selections	Options	
[Quality]	Select the copy quality for your type of document.	
[Tray Use]	Select a paper tray for the next copy.	
[Enlarge/Reduce]	[100%]	-
	[Enlarge]	Select an enlargement ratio for the next copy.
	[Reduce]	Select a reduction ratio for the next copy.
	[Auto]	Adjusts the copy size to fit the paper size you have set.
	[Custom(25-400%)]	Enter an enlargement or reduction ratio.
[Density]	Increase the density to make the text darker. Decrease the density to make the text lighter.	
[2-sided Copy]	Select to copy on both sides of the paper. 1-sided -> 2-sided <div style="text-align: center;">  </div> 2-sided -> 2-sided <div style="text-align: center;">  </div>	
[2-sided Copy Page Layout] (Available only under certain set- tings)	Select long edge binding or short edge binding.	
[Contrast]	Increase the contrast to make an image clearer. Decrease the contrast to make an image more subdued.	

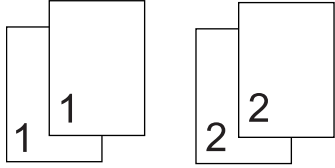
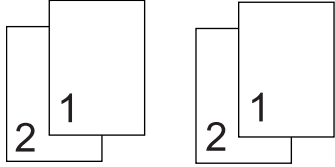
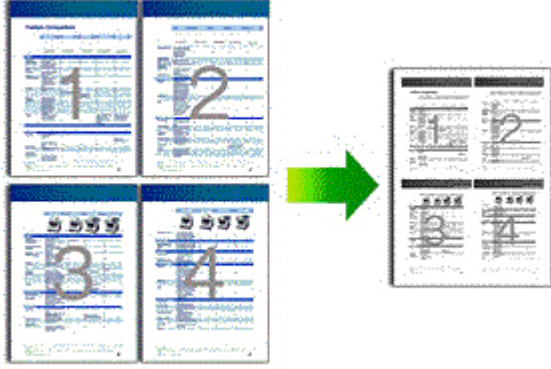
Menu selections	Options
[Stack/Sort]	<p>Select to stack or sort multiple copies.</p> <p>Stack</p>  <p>Sort</p> 
[Page Layout]	<p>Make N in 1 copies. 4 in 1</p> 
[Auto Deskew]	Set the machine to automatically correct skewed copies.

## bizhub 5021i

To change the Copy settings, press [Options].

Menu selections	Options
[Quality]	Select the copy quality for your type of document.
[Tray Use]	Select a paper tray for the next copy.
[Enlarge/Reduce]	[100%] -
	[Enlarge] Select an enlargement ratio for the next copy.
	[Reduce] Select a reduction ratio for the next copy.
	[Auto] Adjusts the copy size to fit the paper size you have set.
	[Custom(25-400%)] Enter an enlargement or reduction ratio.
[Density]	Increase the density to make the text darker. Decrease the density to make the text lighter.

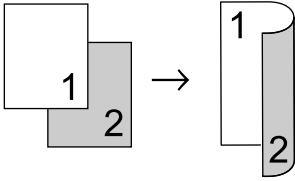
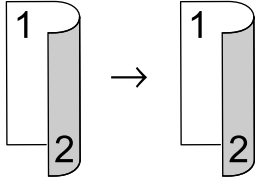
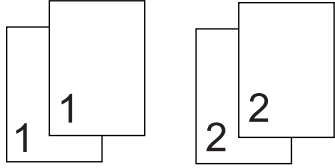
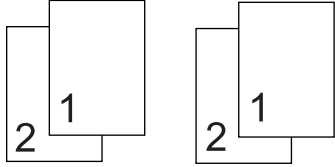
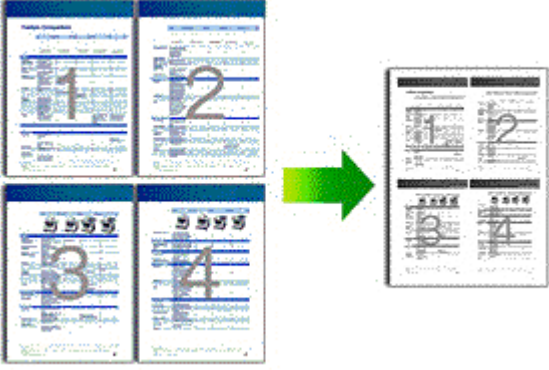
Menu selections	Options
[2-sided Copy]	<p>Select to copy on both sides of the paper. 1-sided -&gt; 2-sided</p>  <p>2-sided -&gt; 2-sided</p> 
[2-sided Copy Page Layout] (Available only under certain settings)	<p>Select long edge binding or short edge binding.</p>
[Contrast]	<p>Increase the contrast to make an image clearer. Decrease the contrast to make an image more subdued.</p>
[Stack/Sort]	<p>Select to stack or sort multiple copies. Stack</p>  <p>Sort</p> 
[Page Layout]	<p>Make N in 1 copies. 4 in 1</p> 
[Auto Deskew]	<p>Set the machine to automatically correct skewed copies.</p>

### 5.2.2 Copy on both sides of the paper (2-sided)

Reduce the amount of paper you use by copying onto both sides of the paper.

You must choose a 2-sided copy layout from the following options before you can start 2-sided copying.

The layout of your original document determines which 2-sided copy layout you should choose.

Portrait

- 2-sided to 2-sided

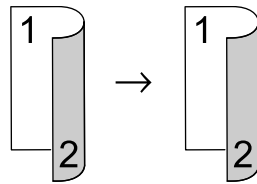

- 1-sided to 2-sided (Long Edge Flip)

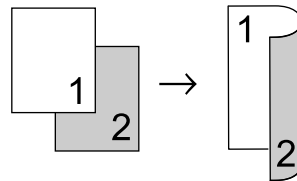

- 1-sided to 2-sided (Short Edge Flip)

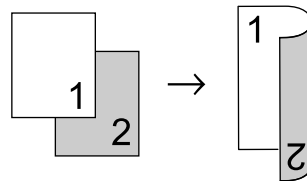

Landscape

- 2-sided to 2-sided

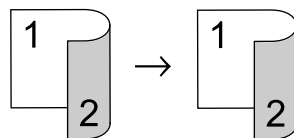

- 1-sided to 2-sided (Long Edge Flip)

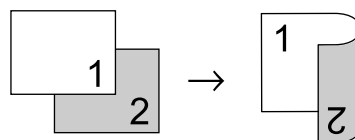

- 1-sided to 2-sided (Short Edge Flip)

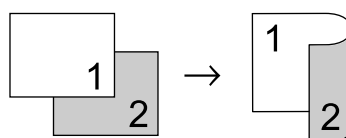

- ✓ For important or fragile documents, use the machine's scanner glass, not the ADF.

- ✓ To use the automatic 2-sided copy feature, you must load your document in the ADF.
  - ✓ When you manually make 2-sided copies from a 2-sided document, use the scanner glass.
  - ✓ Select A4 sized paper when using the 2-sided copy option.
- 1 Load your document.
    - Load your 2-sided document in the ADF. If you use the scanner glass for your 2-sided document, select the [1-sided -> 2-sided] option.
  - 2 Press  [Copy].
  - 3 Enter the number of copies.
  - 4 Press [Options] > [2-sided Copy].
  - 5 Do one of the following:
    - To make 2-sided copies of a 2-sided document, press [2-sided -> 2-sided].
    - To make 2-sided copies from a 1-sided document, follow these steps:
      - To change the layout options, press [Layout], and then press [Long Edge Flip] or [Short Edge Flip].
      - Press [1-sided -> 2-sided].
  - 6 When finished, press [OK]. (If the [OK] button is displayed.)
  - 7 Press [Start].

If you placed the document in the ADF, the machine scans the pages and starts printing.
  - 8 If you are using the scanner glass, repeat the following steps for each page of the document: (For a 2-sided document, turn the sheet over along the long edge to scan the other side.)
    - Place the next page on the scanner glass, and then press [Continue] to scan the page.
    - After scanning all the pages, press [Finish].

### 5.2.3 Copy an ID card

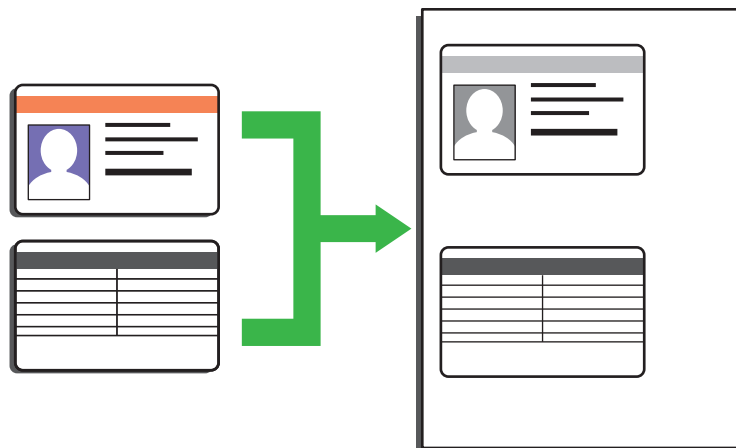

You may copy an identification card only to the extent permitted under applicable laws. For more detailed information, see the "Safety Information".

**bizhub 4221i**

- 1 Place your identification card face down near the upper left corner of the scanner glass.

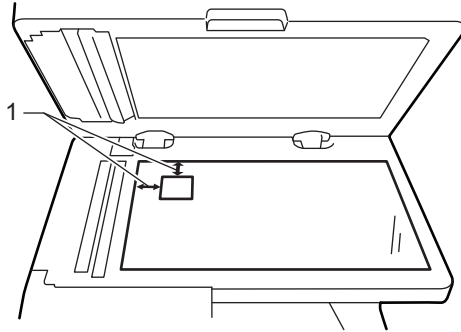

→ 1: Distance 4.0 mm or greater (top, left)

- 2 Press  [Copy].
- 3 Press [ID].
- 4 Enter the number of copies.
- 5 Press [Start].  
The machine scans one side of the identification card.
- 6 After the machine has scanned the first side, turn over the identification card.

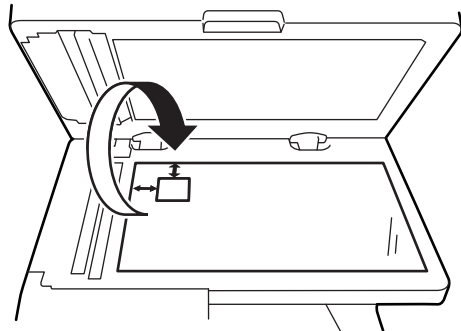

- 7 Press [Continue] to scan the other side.

**bizhub 5021i**

- 1 Place your identification card face down near the upper left corner of the scanner glass.

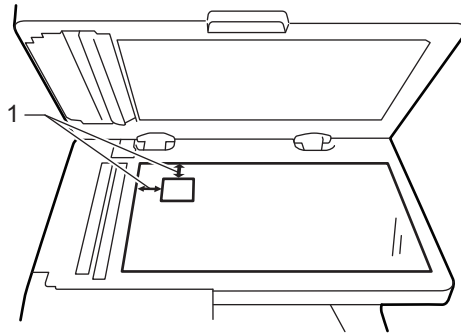

→ 1: Distance 4.0 mm or greater (top, left)

- 2 Press  [Copy].
- 3 Press > on the touchscreen, and then select [2in1(ID)].
- 4 Enter the number of copies.
- 5 Press [Start].  
The machine scans one side of the identification card.
- 6 After the machine has scanned the first side, turn over the identification card.

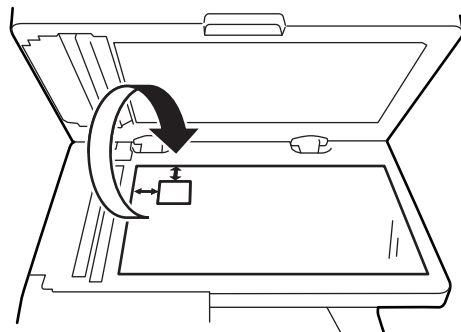

- 7 Press [Continue] to scan the other side.



---

**6** Scan

---



## 6 Scan

### 6.1 Scan from your computer

There are several ways you can use your computer to scan photos and documents on your machine. Use the software applications we provide or use your favourite scanning application.

#### 6.1.1 Scan using iPrint&Scan

- 1 Start [iPrint&Scan].
  - Windows: Launch  ([iPrint&Scan]).
  - Mac: In the [Finder] menu bar, click [Go] > [Applications], and then double-click the [iPrint&Scan] icon.The [iPrint&Scan] screen appears.
- 2 If your machine is not selected, click the [Select your Machine] button, and then select your model's name from the list. Click [OK].
- 3 Click [OK] again.
- 4 Click the [Scan] icon, and then follow the on-screen instructions to scan your documents.

## 6.2 Scan using the scan button on your machine

### 6.2.1 Save scanned data to a folder as a PDF file

Scan documents and save them to a folder on your computer as PDF files.

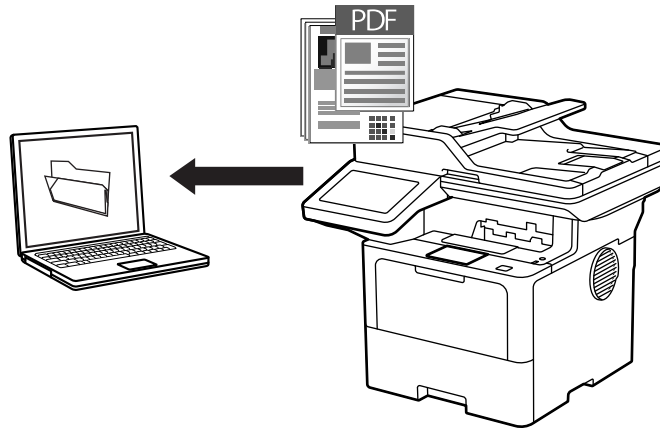

- ✓ Use the Scan button on the machine to make temporary changes to the scan settings. To make permanent changes, use **iPrint&Scan**.

- 1 Load your document.
- 2 Press [Scan] > [to PC] > [to File].
- 3 If the machine is connected over the network, select the computer name where you want to send data.
  - If the LCD prompts you to enter a PIN for the computer, enter the four-digit PIN on the LCD, and then press [OK].
- 4 (**bizhub 5021i**) To change the settings, press [Options], and then select the scan settings you want to change. (**bizhub 4221i**) To change the settings, press  [Options], and then select the scan settings you want to change. If you use the default settings, skip this step.

- [2-sided Scan]
- [Scan Settings]
- [Colour Setting]
- [Resolution]
- [File Type]
- [Document Size]
- [Brightness]
- [Contrast] (available only for the [Colour] and [Grey] options)
- [Auto Deskew]
- [Skip Blank Page]
- [Skip Blank Page Sensitivity]
- [Remove Background Colour] (available only for the [Colour] and [Grey] options)
- [Margin Settings] (available only for certain models)
- [B&W TIFF Compress]

To change scan settings, a computer with the **iPrint&Scan** software installed must be connected to your machine.

If your machine displays the [OK] button, press [OK].

To save the settings as a shortcut, press [Save as Shortcut].

- 5 Press [Start].

The machine starts scanning. If using the machine's scanner glass, follow the touchscreen instructions to complete the scanning job.

---

**7** Fax

---











## 7 Fax

### 7.1 Before faxing

#### 7.1.1 Set your Station ID

Set the machine to print your Station ID and the fax's date and time at the top of each fax you send.

- 1 Press  [Settings] > [All Settings] > [Initial Setup] > [Station ID] > [Fax].
  - If your machine displays the [All Settings] menu on the Home screen, skip the [Settings] menu.
- 2 Enter your fax number (up to 20 digits) using the LCD, and then press [OK].
- 3 Press [Tel].
- 4 Enter your telephone number (up to 20 digits) using the LCD, and then press [OK].
- 5 Press [Name].
- 6 Enter your name (up to 20 characters) using the LCD, and then press [OK].
  - Press  to cycle between letters, numbers and special characters. (The characters available may differ depending on your country.)
  - If your machine displays   #+ =, press   #+ =.
  - If you enter an incorrect character, press ◀ or ▶ to move the cursor to it and press . Press the correct character.
  - To enter a space, press [Space] or ▶.
- 7 Press .



#### 7.1.2 Set telephone line compatibility for interference and VoIP systems

Problems sending and receiving faxes due to possible interference on the telephone line may be solved by reducing the modem speed to minimise errors in fax transmission. If you are using a Voice over IP (VoIP) service, we recommend changing the compatibility to Basic (for VoIP).



##### Tips

- VoIP is a type of phone system that uses an Internet connection, rather than a traditional phone line.
- Telephone providers frequently bundle VoIP together with Internet and cable services.

#### **bizhub 4221i**

- 1 Press  [Settings] > [All Settings] > [Initial Setup] > [Compatibility].
  - If your machine displays the [All Settings] menu on the Home screen, skip the [Settings] menu.
- 2 Press the option you want.
  - Select [High] to set the modem speed to 33600 bps.
  - Select [Normal] to set the modem speed to 14400 bps.
  - Select [Basic(for VoIP)] to reduce the modem speed to 9600 bps and turn off Error Correction Mode (ECM). Unless interference is a recurring problem on your telephone line, you may prefer to use this option only when needed.
- 3 Press .

## bizhub 5021i

- 1 Press  [Settings] > [All Settings] > [Initial Setup] > [Compatibility].
  - If your machine displays the [All Settings] menu on the Home screen, skip the [Settings] menu.
- 2 Press the option you want.
  - Select [High] to set the modem speed to 33600 bps.
  - Select [Normal] to set the modem speed to 14400 bps.
  - Select [Basic(for VoIP)] to reduce the modem speed to 9600 bps and turn off Error Correction Mode (ECM). Unless interference is a recurring problem on your telephone line, you may prefer to use this option only when needed.
- 3 Press .

### 7.1.3 Receive modes

Some receive modes answer automatically (Fax Only Mode and Fax/Tel Mode). You may want to change the Ring Delay before using these modes.

#### Fax Only mode

([Fax Only] in the machine's menu)

Fax Only Mode automatically answers every call as a fax.

#### Fax/Tel mode

([Fax/Tel] in the machine's menu)

Fax/Tel Mode helps you manage incoming calls, by recognising whether they are fax or voice calls and handling them in the following ways:

- Faxes will be received automatically.
- Voice calls will start the F/T ring to tell you to pick up the call. The F/T ring is a fast pseudo/double-ring made by your machine.

#### Manual mode

([Manual] in the machine's menu)

Manual Mode turns off all automatic answering operations unless you are using the BT Call Sign feature.

To receive a fax in Manual Mode, lift the handset of the external telephone connected to the machine.

When you hear fax tones (short repeating beeps), press the buttons in the table to receive a fax. Use the Fax Detect feature to receive faxes when you have lifted a handset on the same line as the machine.

To receive a fax: [Fax Start] > [Receive]

#### External TAD mode

([External TAD] in the machine's menu)

External TAD Mode lets an external answering device manage your incoming calls.

Incoming calls will be handled in the following ways:



- Faxes will be received automatically.
- Voice callers can record a message on the external TAD.

### 7.1.4 Choose the correct receive mode

You must choose a Receive Mode depending on the external devices and telephone services you have on your line.

By default, your machine will automatically receive any faxes that are sent to it. The steps below will help you select the correct mode.



1. Do you want to use the telephone feature of your machine (if available), an external telephone or external telephone answering device connected on the same line as the machine?
  - If Yes, proceed to the next step.
  - If No, choose Fax Only Mode.
2. Are you using the voice message function of an external telephone answering device?
  - If Yes, choose External TAD Mode.
  - If No, proceed to the next step.
3. Do you want the machine to answer fax and telephone calls automatically?
  - If Yes, choose Fax/Tel Mode.
  - If No, choose Manual Mode.

- 1 Press  [Settings] > [All Settings] > [Fax] > [Setup Receive] > [Receive Mode].
  - If your machine displays the [All Settings] menu on the Home screen, skip the [Settings] menu.
  - (U.K. only) If you cannot change the [Receive Mode] option, make sure the BT Call Sign feature is set to Off.
- 2 Press [Fax Only], [Fax/Tel], [External TAD], or [Manual].
- 3 Press .

### 7.1.5 Set the F/T Ring Time (Fast double-ring)

When you set the Receive Mode to Fax/Tel Mode, if the call is a fax, your machine will automatically receive it. However, if it is a voice call, the machine will sound the F/T ring (fast double-ring) for the time you set in the F/T Ring Time option. When you hear the F/T ring, it means that a voice caller is on the line.

- ✓ The F/T Ring Time feature works when you set Fax/Tel Mode as the Receive Mode.
- ✓ Because the F/T ring is made by the machine, extension and external telephones will not ring; however, you can still answer the call on any telephone.

- 1 Press  [Settings] > [All Settings] > [Fax] > [Setup Receive] > [F/T Ring Time].
  - If your machine displays the [All Settings] menu on the Home screen, skip the [Settings] menu.
- 2 Press how long you want the machine to ring to alert you that you have a voice call.
- 3 Press .

#### Tips

Even if the caller hangs up during the pseudo/double-ringing, the machine will continue to ring for the set time.

### 7.1.6 Set the number of rings before the machine answers (Ring Delay)

When somebody calls your machine, you will hear the normal telephone ring sound. The number of rings is set in the Ring Delay option.

- ✓ The Ring Delay setting sets the number of times the machine rings before it answers in the Fax Only and Fax/Tel Modes.
- ✓ If you have external or extension telephones on the same line as the machine, choose the maximum number of rings.

**1** Press  [Settings] > [All Settings] > [Fax] > [Setup Receive] > [Ring Delay].

→ If your machine displays the [All Settings] menu on the Home screen, skip the [Settings] menu.



**2** Press the number of rings you want.

→ If you select [0], the machine will answer immediately and the line will not ring at all (available only for some countries).

**3** Press .



## 7.2 Store fax numbers

### 7.2.1 Store address book numbers

- 1 Press  [Fax] > [Address Book].
- 2 Press [Edit].
- 3 Press [Add New Address].
- 4 Press [Name].
- 5 Enter the name using the LCD (up to 16 characters), and then press [OK].
- 6 Press [Address].
- 7 Enter the fax or telephone number using the LCD (up to 20 digits), and then press [OK].
  - To store an email address to use with Internet Fax or Scan to Email server, press  and enter the email address and press [OK].
- 8 Press [OK].

To store another Address Book number, repeat these steps.
- 9 Press .

### 7.2.2 Change or delete address book names or numbers

- 1 Press  [Fax] > [Address Book] > [Edit].
- 2 Do one of the following:
  - Press [Change] to edit the names or fax or telephone numbers. Swipe up or down or press ▲ or ▼ to display the number you want to change, and then press it.
    - To change the name, press [Name]. Enter the new name (up to 16 characters) using the LCD, and then press [OK].
    - To change the fax or telephone number, press [Address]. Enter the new fax or telephone number (up to 20 digits) using the LCD, and then press [OK].
  - To delete numbers, press [Delete]. Select the fax or telephone numbers you want to delete by pressing them to display a check mark, and then press [OK].
- 3 Press .

## 7.3 Send and receive a fax using your machine

### 7.3.1 Send a fax

1 Do one of the following:

→ Place the document face up in the ADF. (If you are copying multiple pages, we recommend using the ADF.)

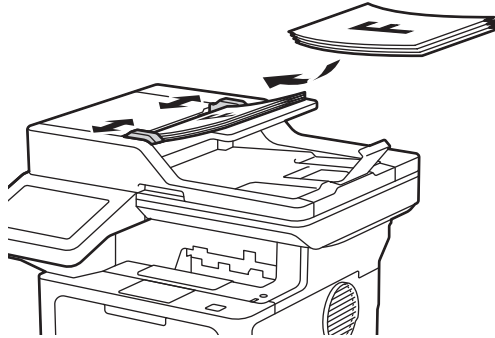

→ Place the document face down on the scanner glass.

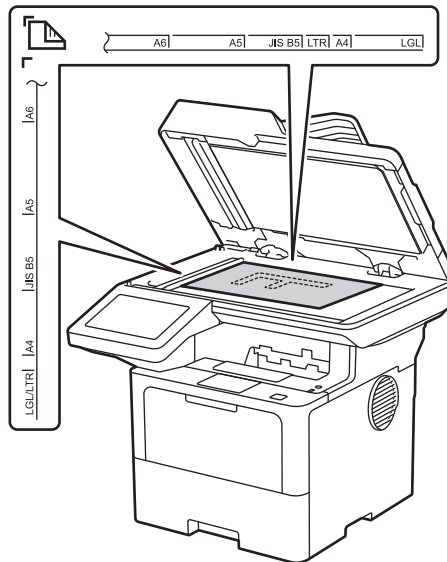

2 Press  [Fax].

→ If the Fax Preview option is set to [On], press  [Fax] > [Sending Faxes].

3 Enter the fax number.

→ Using the dial pad  
Press the digits to enter the fax number.

1	2	3
4	5	6
7	8	9
*	0	#

## → Using the Address Book

Press  [Address Book], and then do one of the following:

Swipe up or down or press ▲ or ▼ to display the number you want, and then press it.

Press  [Search], and then enter the name or the first letter of the name and press [OK]. Press the name you want to dial.

When finished, press [Apply].

## → Using the Call History

Press  [Call History], and then press the [Outgoing Call] option.

Swipe up or down or press ▲ or ▼ to display the fax number you want, and then press it.

To send a fax, press [Apply].

**4** Press [Fax Start].

The machine scans and sends the document.

If you placed the document on the scanner glass, follow the instructions in the table.

Option	Description
[Yes]	To scan the next page, press the [Yes] option, and then place the next page on the scanner glass. Press [OK] to scan the page.
[No]	After you have scanned the last page, press the [No] option. The machine sends the document.

To stop faxing, press , and then press .

When the LCD displays [Cancel Job?], press [Yes].

## 7.4 Fax using your computer (PC-FAX)

### 7.4.1 Send a fax using PC-FAX (Windows)

- ✓ PC-FAX supports only monochrome faxes. A monochrome fax will be sent even if the original data is in colour and the receiving fax machine supports colour faxes.
- 1 Create a file in any application on your computer.
- 2 Select the print command in your application.
- 3 Select your model with [PC-FAX] in the name as your printer, and then complete your print operation. The [PC-FAX] dialog box appears.
- 4 Type a fax number using one of the following methods:
  - Click the numbers on the dial pad to type the number, and then click [Add Send Address]. If you select the [Dial Restriction] checkbox, a confirmation dialog box will appear for you to re-type the fax number using the keyboard. This feature helps to prevent transmissions to the wrong destination.
  - Click the [Address Book] button, and then select a member or group from the Address Book. If you make a mistake, click [All Clear] to delete all entries.
- 5 To include a cover page, select the [Add Cover Page] checkbox. You can also click  to create or edit a cover page.
- 6 Click [Start] to send the fax.
  - To cancel the fax, click [Cancel].
  - To redial a number, click [Redial] to show the last five fax numbers, select a number, and then click [Start].

### 7.4.2 Receive faxes on your computer (Windows)

Use PC-FAX software to receive faxes on your computer, screen them and print only those faxes you want.

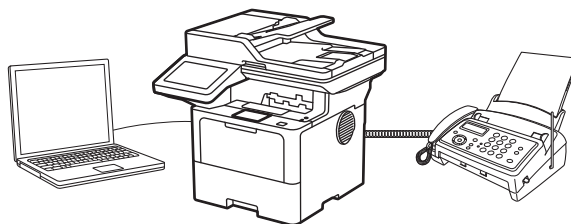

#### Receive faxes Using PC-FAX Receive

PC-FAX Receive software lets you view and store faxes on your computer. It is automatically installed when you install your machine's software and drivers and works on locally or network-connected machines.

When you turn your computer off, your machine will continue to receive and store faxes in your machine's memory. The machine's LCD will display the number of stored faxes received. When you start this application, the software will transfer all received faxes to your computer at once. You can enable the Backup Print option if you want the machine to print a copy of the fax before the fax is sent to your computer, or before the computer is switched off. You can configure the Backup Print settings from your machine.

- ✓ PC-FAX Receive supports only monochrome faxes.
- ✓ We recommend selecting the [Start PC-FAX Receive on computer startup] checkbox so that the software runs automatically and transfers any faxes when you turn your computer on.

- 1 Launch  ([KONICA MINOLTA Utilities]), and then click the drop-down list and select your model name (if not already selected).
- 2 Click [PC-FAX] in the left navigation bar, and then click [Receive].
- 3 Confirm the message and click [Yes].

The [PC-FAX Receive] window appears. The  ([PC-Fax Receive (Ready)]) icon also appears in your computer task tray.



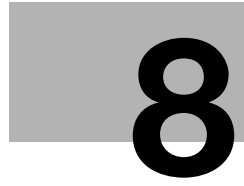

## Troubleshooting



## 8 Troubleshooting

Use this section to resolve typical problems you may encounter when using your machine. You can correct most problems yourself.





First, check the following:

- The machine's power cord is connected correctly and the machine's power is on.
- All of the protective materials have been removed.
- Paper is loaded correctly in the paper tray.
- The interface cables are securely connected to the machine and the computer, or the wireless connection is set up on both the machine and your computer.
- Error and maintenance messages





If you did not solve the problem with the checks, identify the problem and then see the instructions in the following table. If you cannot resolve the error, see the "User's Guide".

### 8.1 Error and maintenance messages

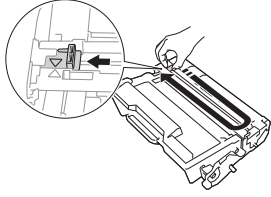
The most common error and maintenance messages are shown in the table.

Error Message	Cause	Action
[2-sided Disabled]	The back cover of the machine is not closed completely.	Close the back cover of the machine until it locks in the closed position.
	The 2-sided tray is not installed completely.	Install the 2-sided tray firmly in the machine.
[Cannot Scan]	The document is too long for 2-sided scanning.	Press  . For 2-sided scanning, use A4 size paper. Other paper must be within the following size: Length: 147.3 to 355.6 mm Width: 105 to 215.9 mm
[Cannot Scan]	The machine has a mechanical problem.	<ul style="list-style-type: none"> <li>• Press and hold  to turn the machine off, and then turn it on again.</li> <li>• If the problem continues, contact customer support.</li> </ul>
[Cover is Open]	The front cover is not completely closed.	Open and then firmly close the front cover of the machine.
[Cover is Open]	The fuser cover is not completely closed or paper was jammed in the back of the machine when you turned on the power.	Close the fuser cover located inside the back cover of the machine. Make sure paper is not jammed inside the back of the machine, and then close the fuser cover.
[Cover is Open]	The ADF cover is not completely closed.	Close the ADF cover. If the error message remains, press  .
[Document Jam]	The document was not inserted or fed correctly, or the document scanned from the ADF was too long.	Remove the jammed paper from the ADF unit. Clear any debris or scraps of paper from the ADF unit paper path. Press  .

Error Message	Cause	Action
[Drum !]	The corona wire on the imaging unit must be cleaned.	Clean the corona wire on the imaging unit.  If the problem continues, replace the imaging unit with a new one.
	The imaging unit or the toner cartridge and imaging unit assembly is not installed correctly.	Remove the imaging unit, remove the toner cartridge from the imaging unit, and put the toner cartridge back into the imaging unit. Reinstall the imaging unit in the machine.
[Jam 2-sided]	The paper is jammed in the 2-sided tray or inside the back cover.	Remove the 2-sided tray and open the back cover to pull out all jammed paper.
[Jam Inside]	The paper is jammed inside the machine.	Open the front cover, remove the toner cartridge and imaging unit assembly, and pull out all jammed paper. Close the front cover.
[Jam MP Tray]	The paper is jammed in the MP tray.	Remove all jammed paper from in and around the MP tray. Press [Retry].
[Jam Rear]	The paper is jammed in the back of the machine.	Open the fuser cover and remove all jammed paper. Close the fuser cover. If the error message remains, press [Retry].
[Jam Tray 1] [Jam Tray 2] [Jam Tray 3]	The paper is jammed in the indicated paper tray.	Pull out the paper tray and remove all jammed paper as shown in the animation on the LCD.
[Media Type Mismatch]	The media type specified in the printer driver differs from the paper type specified in the machine's menu.	Load the correct type of paper in the tray indicated on the LCD, and then select the correct media type in the Paper Type setting on the machine. Press [Retry].
[No Drum]	The imaging unit is not installed correctly.	Reinstall the toner cartridge and imaging unit assembly.
[No Paper]	The machine is out of paper, or paper is not loaded correctly in the paper trays.	<ul style="list-style-type: none"> <li>• Refill paper in the paper trays. Make sure the paper guides are set to the correct size.</li> <li>• If paper is in the tray, remove it and load it again. Make sure the paper guides are set to the correct size.</li> <li>• Do not overfill the paper tray.</li> </ul>
[No Paper Fed T1] [No Paper Fed T2] [No Paper Fed T3]	The machine cannot feed paper from the indicated paper tray.	Pull out the paper tray indicated on the LCD and remove all jammed paper.
[No Paper MP Tray]	The MP tray is out of paper, or paper is not loaded correctly in the MP tray.	Do one of the following: <ul style="list-style-type: none"> <li>• Refill paper in the MP tray. Make sure the paper guides are set to the correct size.</li> <li>• If paper is in the tray, remove it and load it again. Make sure the paper guides are set to the correct size.</li> </ul>
[No Paper] [No Paper T1] [No Paper T2] [No Paper T3] [No Paper Tray 1] [No Paper Tray 2] [No Paper Tray 3]	The machine cannot feed paper from the indicated paper tray.	Do one of the following: <ul style="list-style-type: none"> <li>• Refill paper in the paper tray indicated on the LCD. Make sure the paper guides are set to the correct size.</li> <li>• If paper is in the tray, remove it and load it again. Make sure the paper guides are set to the correct size.</li> <li>• Do not overfill the paper tray.</li> </ul>

Error Message	Cause	Action
[No Toner]	The toner cartridge is not installed or is not installed correctly.	Remove the toner cartridge and imaging unit assembly. Remove the toner cartridge from the imaging unit, and reinstall the toner cartridge back in the imaging unit. Reinstall the toner cartridge and imaging unit assembly back in the machine. If the problem continues, replace the toner cartridge with a new one.
[No Tray T1] [No Tray T2] [No Tray T3]	The paper tray is not installed or not installed correctly.	Reinstall the paper tray indicated on the LCD.
[Out of Memory]	The machine's memory is full.	If a fax-sending or copy operation is in process, do one of the following: <ul style="list-style-type: none"> <li>• Press [Send Now] to send the pages scanned so far.</li> <li>• Press [Partial Print] to copy the pages scanned so far.</li> <li>• Press [Quit] or  and wait until the other operations that are in progress finish, and then try again.</li> </ul> If a scan operation is in progress, do one of the following: <ul style="list-style-type: none"> <li>• Split the document into multiple parts.</li> <li>• Reduce the resolution.</li> <li>• Reduce the file size.</li> <li>• Select the high compression PDF file type.</li> <li>• Clear faxes from the memory.</li> </ul> If a print operation is in process Press  and reduce the print resolution.
[Output Tray Full]	The output paper tray is full.	Remove the printed paper from the Face-down output tray.
[Paper Low] [Paper Low T1] [Paper Low T2] [Paper Low T3]	The paper tray is nearly empty.	Refill the paper in the paper tray indicated on the LCD.
[Print Data Full]	The machine's memory is full.	Press  and delete the previously stored secure print data.
[Received Fax]	An unprinted received fax is waiting to print on the correct size paper.	To print the received fax, load the correct size of paper in the tray indicated on the LCD. Paper sizes available for fax printing are A4, Letter, Legal, Folio, Mexico Legal and India Legal.
[Replace Toner]	The toner cartridge is at the end of its life. After stopping printing, faxes are stored in memory while memory is available.	Replace the toner cartridge with a new one.
[Self-Diagnostic]	The fuser unit does not work correctly. The fuser unit is too hot.	Press and hold  to turn the machine off, wait a few seconds, and then turn it on again. Leave the machine idle for 15 minutes with the power on.
[Size Error]	The paper tray you selected does not support the paper size specified in the printer driver.	Change the printer driver setting or machine's tray setting so that the paper size selected in the printer driver matches the paper size loaded in the tray you selected.

Error Message	Cause	Action
[Size Error 2-sided]	<p>The paper size specified in the machine's paper size setting is not suitable for automatic 2-sided printing.</p> <p>The paper in the tray is not the correct size and is not suitable for automatic 2-sided printing.</p>	<p>Press  (if required).            Load the correct size of paper in the tray and set the tray for that paper size.            Choose a paper size suitable for 2-sided printing. The paper size suitable for automatic 2-sided printing is A4.</p>
[Size Mismatch]	The paper in the tray is not the correct size.	Load the correct size of paper in the tray indicated on the LCD and set the size of paper for the tray.
[Supplies] [Drum End Soon]	The imaging unit is near the end of its life.	Order a new imaging unit before the LCD displays [Replace Drum].
[Supplies] [Replace Drum]	It is time to replace the imaging unit.	Replace the imaging unit with a new one.
[Supplies] [Toner Low]	If the LCD displays this message, you can still print. The toner cartridge is near the end of its life.	Order a new toner cartridge now so you have it ready when the LCD displays [Replace Toner].
[Wrong Paper Size MP] [Wrong Paper Size T1] [Wrong Paper Size T2] [Wrong Paper Size T3]	The specified tray ran out of paper during copying and the machine could not feed the same size paper from the next priority tray.	Refill the paper in the paper tray.
[Wrong Toner Cartridge]	The installed toner cartridge is not correct for your machine.	Remove the toner cartridge from the imaging unit, and install a toner cartridge with the correct supply product code.

## 8.2 Telephone and fax problems

Difficulties	Suggestions
Cannot send a fax.	Check all line cord connections. Make sure the telephone line cord is plugged into the telephone wall socket and the LINE socket of the machine. If you subscribe to DSL or VoIP services, contact your service provider for connection instructions.
	Make sure you pressed Fax and the machine is in Fax mode.
	Print the Transmission Verification Report and check for an error.
	Contact your administrator to check your Secure Function Lock settings.
	Ask the other party to check that the receiving machine has paper.
Cannot receive a fax.	If you are using a telephone answering machine (External TAD mode) on the same line as this machine, make sure your answering machine is set up correctly. <ol style="list-style-type: none"> <li>1. Set your answering machine to answer in one or two rings.</li> <li>2. Record the outgoing message on your answering machine.               <ul style="list-style-type: none"> <li>• Record five seconds of silence at the beginning of your outgoing message.</li> <li>• Limit your speaking to 20 seconds.</li> <li>• End your outgoing message with your Remote Activation Code for people sending manual faxes. For example: "After the beep, leave a message or press *51 and Start to send a fax."</li> </ul> </li> <li>3. Set your answering machine to answer calls.</li> <li>4. Set your machine's Receive Mode to External TAD.</li> </ol>
	Make sure your machine's Fax Detect feature is turned On. Fax Detect is a feature that allows you to receive a fax even if you answered the call on an external or extension telephone.
	Turn Auto Reduction on.
Received faxes appear as split or blank pages.	Turn Auto Reduction on.
	Turn Auto Reduction on.
Dialling does not work. (No dial tone)	Check all line cord connections. Make sure the telephone line cord is plugged into the telephone wall socket and the LINE socket of the machine. If you subscribe to DSL or VoIP services, contact your service provider for connection instructions.
	(Available only for some countries.) Change the Tone/Pulse setting.
Poor quality of sent faxes.	Try changing your resolution to Fine or S.Fine. Make a copy to check your machine's scanner operation. If the copy quality is poor, clean the scanner.
Vertical black lines when sending a fax.	Black vertical lines on faxes you send are typically caused by dirt or correction fluid on the glass strip. Clean the glass strip.

## 8.3 Printing problems

Difficulties	Suggestions
No printout	<p data-bbox="592 257 1436 347">Check the machine is not in Power Off mode. If the machine is in Power Off mode, press , and then send the print data again.</p> <p data-bbox="592 351 1436 385">Check that the correct printer driver has been installed and selected.</p> <p data-bbox="592 389 1436 432">Check to see if the machine's control panel displays an error.</p>
The machine does not print on both sides of the paper even though the printer driver setting is 2-sided and the machine supports automatic 2-sided printing.	<p data-bbox="592 436 1436 504">Check the paper size setting in the printer driver. You must select A4 paper. Supported paper weight is 60 to 105 g/m<sup>2</sup>.</p>

## 8.4 Document and paper jams

### 8.4.1 Clear the document jam

#### Document is jammed in the top of the ADF unit

- 1 Remove any paper from the ADF that is not jammed.
- 2 Open the ADF cover.
- 3 Pull the jammed document out to the left. If the document rips or tears, be sure you remove any debris or scraps to prevent future jams.

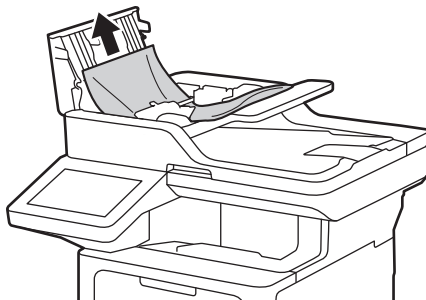

- 4 Close the ADF cover.
- 5 Press .

#### Document is jammed under the document cover

- 1 Remove any paper from the ADF that is not jammed.
- 2 Lift the document cover.
- 3 Pull the jammed document out to the right. If the document rips or tears, be sure you remove any debris or scraps to prevent future jams.

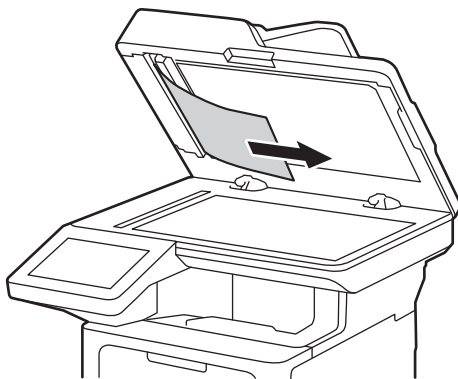

- 4 Close the document cover.
- 5 Press .

## Remove small scraps of paper jammed in the ADF

- 1 Lift the document cover.
- 2 Insert a piece of stiff paper, such as cardstock, into the ADF to push any small paper scraps through.

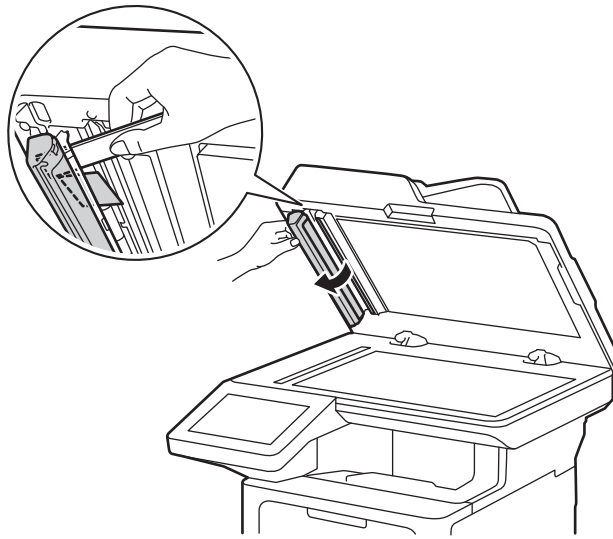

- 3 Close the document cover.
- 4 Press .

### 8.4.2 Clear the paper jam

#### Paper is jammed in the MP tray

If the machine's control panel indicates that there is a jam in the machine's MP tray, follow these steps:

- 1 Remove the paper from the MP tray.
- 2 Slowly remove any jammed paper from in and around the MP tray.

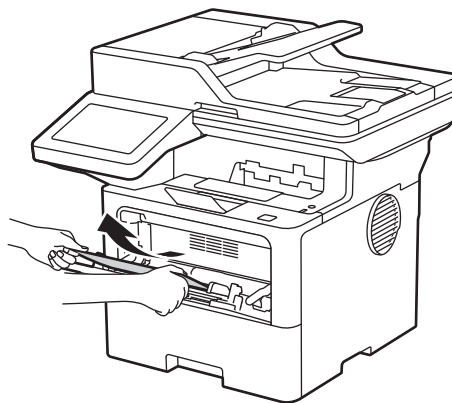

- 3 Fan the paper stack, and then put it back in the MP tray.

- 4 Reload paper in the MP tray and make sure the paper stays under the maximum paper mark (1) on both sides of the tray.

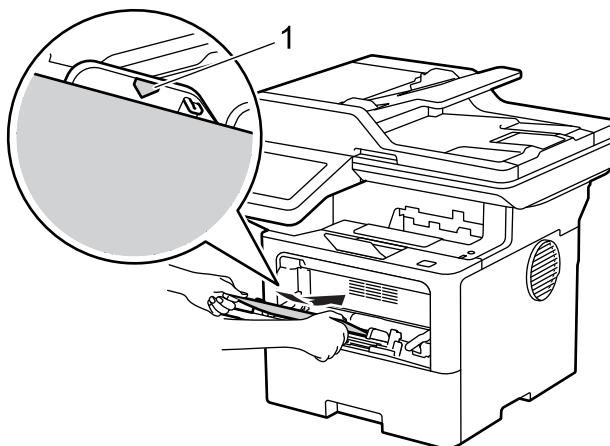

- 5 Follow the instructions on the machine's LCD.

### Paper is jammed in the paper tray

If the machine's control panel indicates that there is a jam in the paper tray, follow these steps:

- 1 Pull the paper tray completely out of the machine.

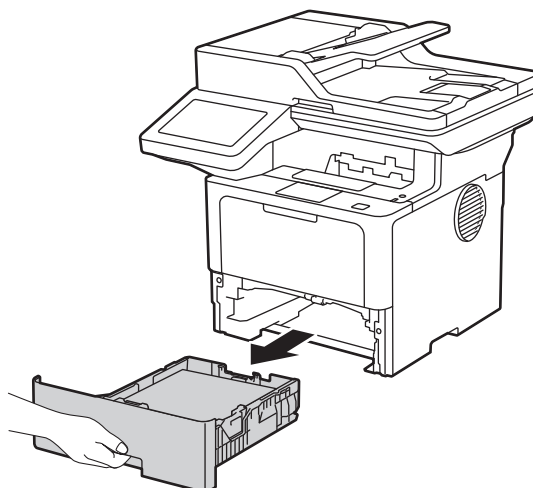

- 2 Slowly pull out the jammed paper.  
→ Pulling the jammed paper downwards using both hands allows you to remove the paper more easily.

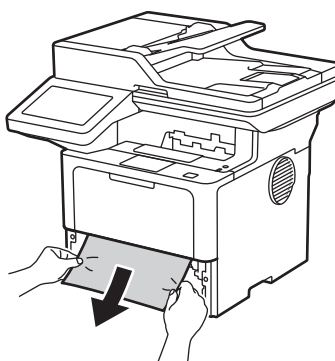

- 3 Fan the stack of paper to prevent further jams, and slide the paper guides to fit the paper size. Load paper in the paper tray.

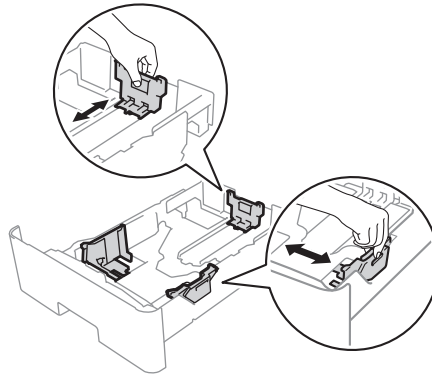

- 4 Make sure the paper is below the maximum paper mark (▼▼▼).

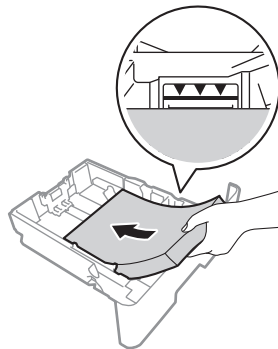

- 5 Put the paper tray firmly back into the machine.

### Paper is jammed in the back of the machine

If the machine's control panel indicates that there is a jam in the back of the machine (Jam Rear), do the following:

- 1 Leave the machine turned on for 10 minutes for the internal fan to cool the extremely hot parts inside the machine.
- 2 Open the back cover.

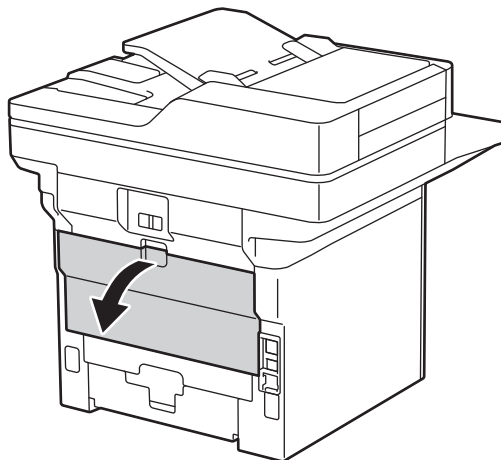

- 3 Pull the blue levers at the left and right sides towards you to release the fuser cover.

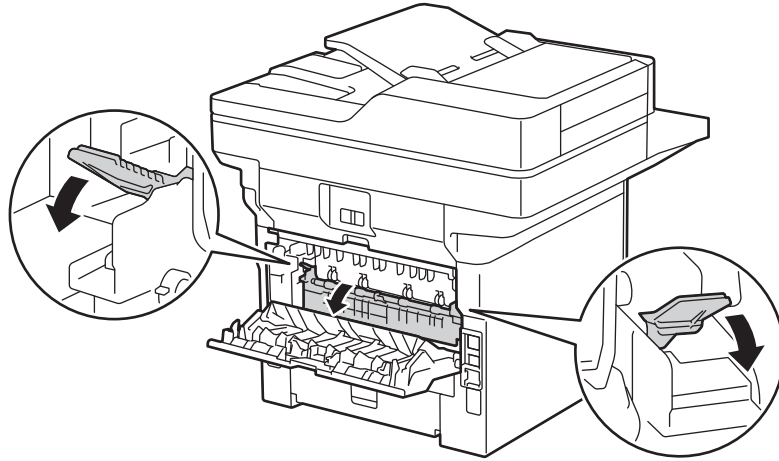

**⚠ WARNING**  
HOT SURFACE

- The machine's internal parts will be extremely hot. Wait for the machine to cool down before touching them.

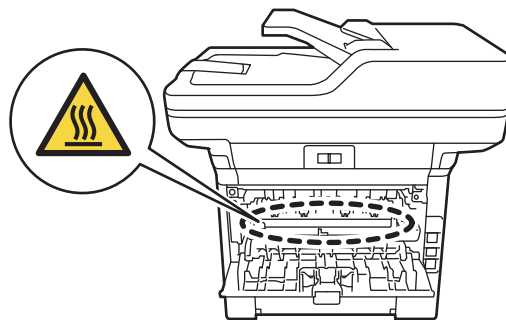

- 4 Use both hands to gently pull the jammed paper out of the machine.

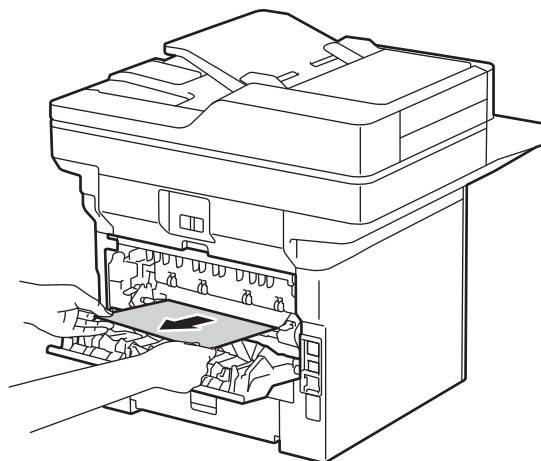

- 5 Close the fuser cover.

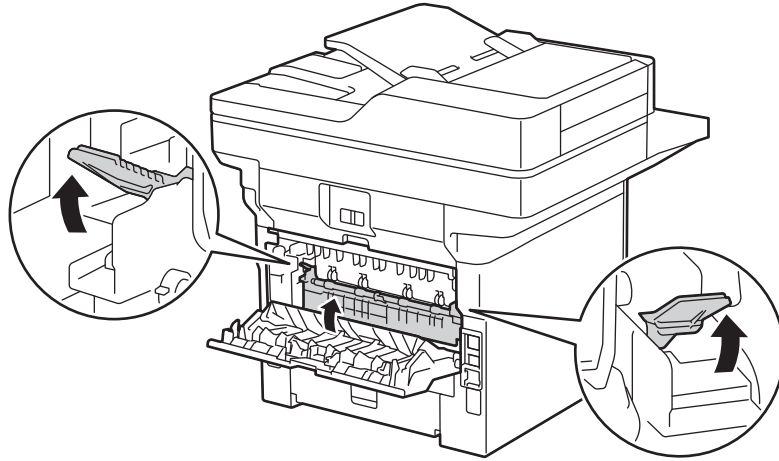

- 6 Close the back cover until it locks in the closed position.

### Paper is jammed inside the machine

If the machine's control panel indicates that there is a jam inside the machine, follow these steps:

- 1 Leave the machine turned on for 10 minutes for the internal fan to cool the extremely hot parts inside the machine.
- 2 Open the front cover.

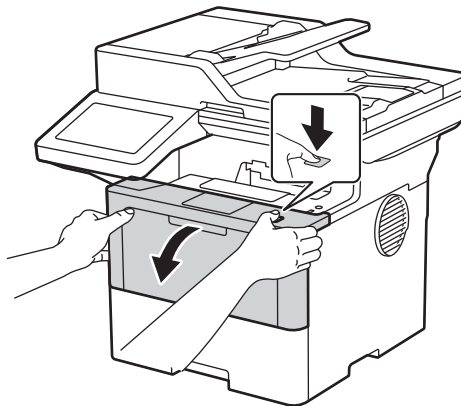

- 3 Remove the toner cartridge and imaging unit assembly.

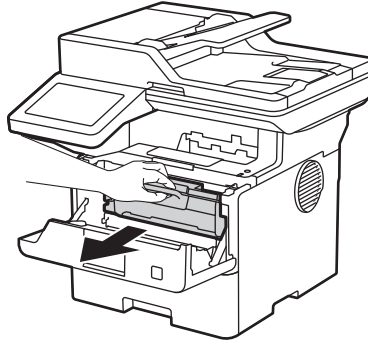

**⚠ WARNING**  
HOT SURFACE

- The machine's internal parts will be extremely hot. Wait for the machine to cool down before touching them.

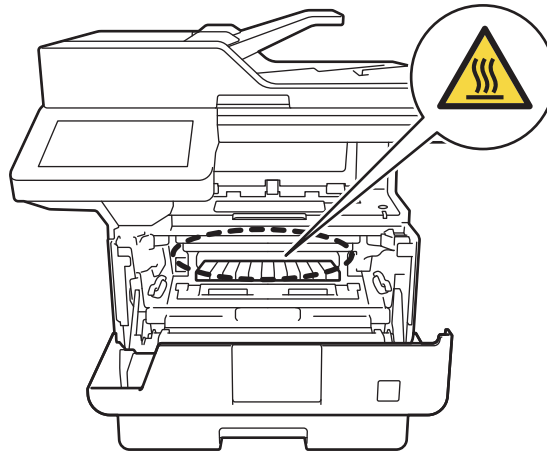

- 4 Pull out the jammed paper slowly.

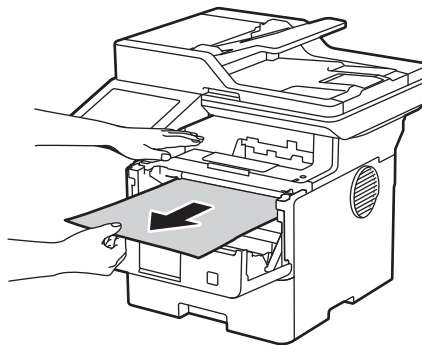

- 5 Install the toner cartridge and imaging unit assembly into the machine.

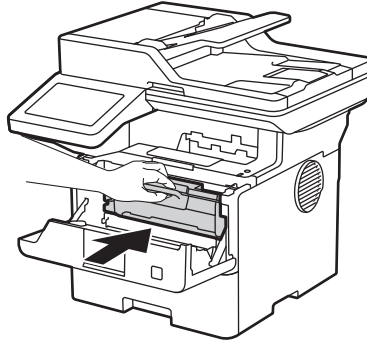

- 6 Close the front cover.

### Paper is jammed in the 2-sided tray

If the machine's control panel indicates that there is a jam in the 2-sided paper tray, follow these steps:

- 1 Leave the machine turned on for 10 minutes for the internal fan to cool the extremely hot parts inside the machine.
- 2 Pull the paper tray completely out of the machine.

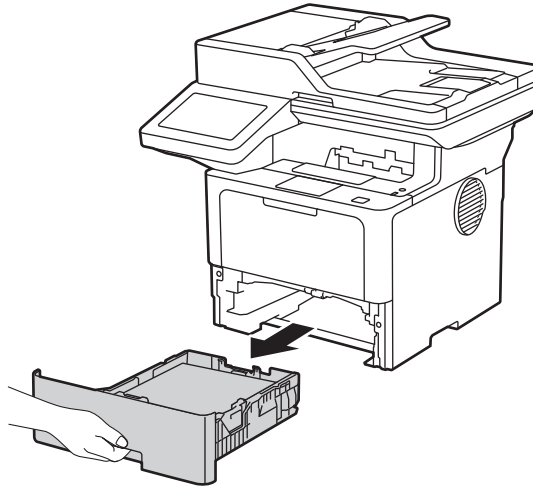

- 3 At the back of the machine, pull the 2-sided tray completely out of the machine.

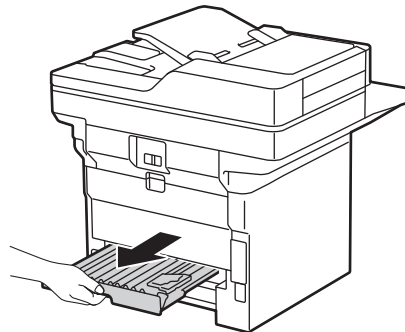

- 4 Pull the jammed paper out of the machine or out of the 2-sided tray.

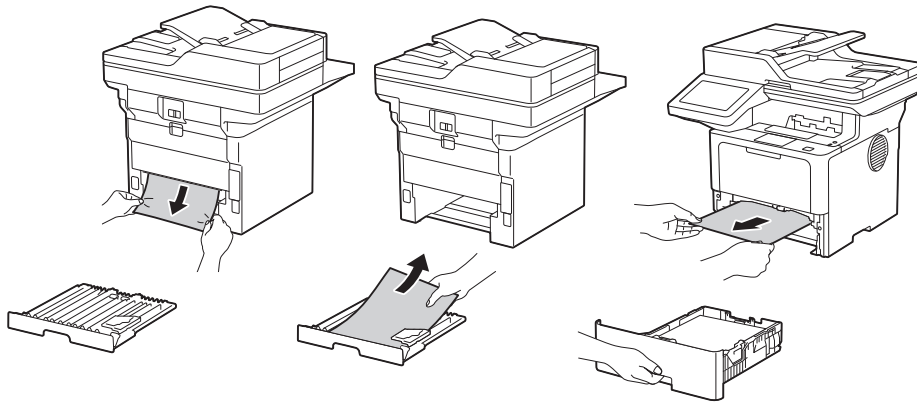

- 5 Remove paper that may have jammed under the machine due to static electricity.

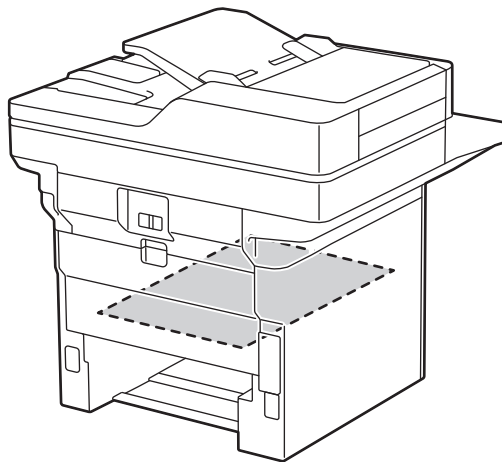

- 6 If paper is not caught inside the 2-sided tray, open the back cover.

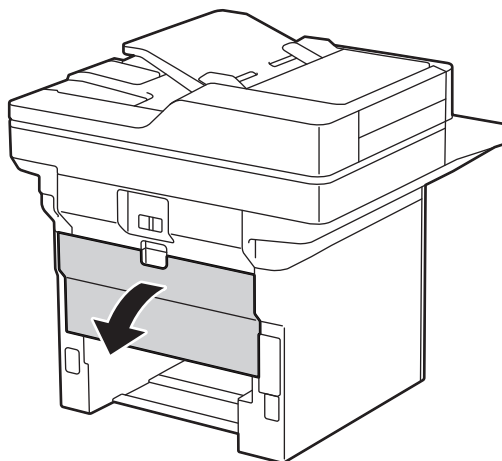

- 7 Pull the blue levers at the left and right sides towards you to release the fuser cover.

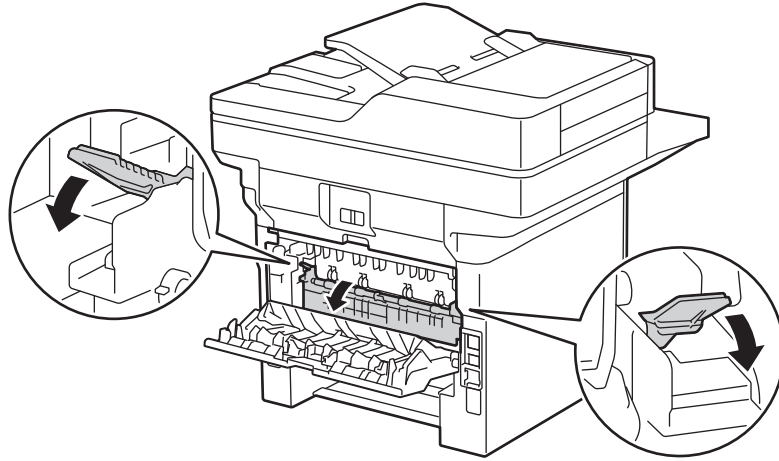

**⚠ WARNING**  
HOT SURFACE

- The machine's internal parts will be extremely hot. Wait for the machine to cool down before touching them.

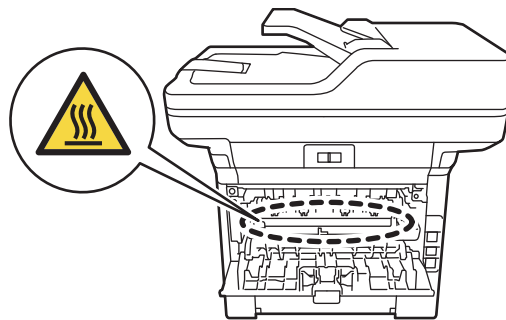

- 8 Use both hands to gently pull the jammed paper out of the back of the machine.

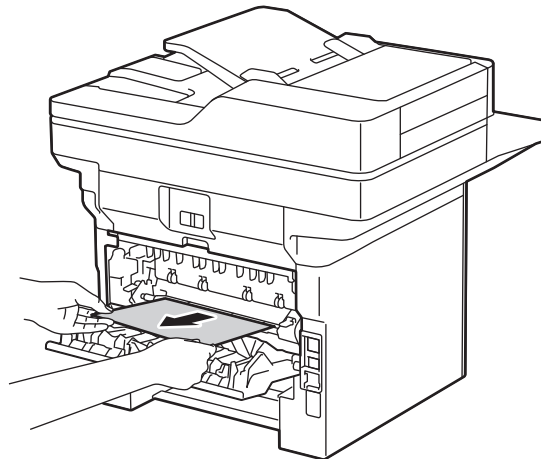

- 9 Close the fuser cover.

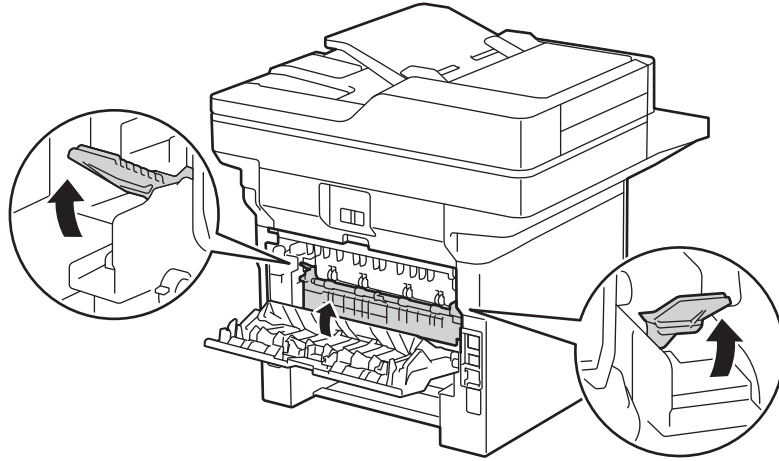

- 10 Close the back cover until it locks in the closed position.
- 11 Push the 2-sided tray firmly back into the back of the machine.
- 12 Push the paper tray firmly back into the front of the machine.

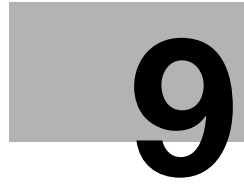

---

A large, bold, black number '9' is centered within a gray square. The square is positioned to the left of the word 'Appendix'.

**Appendix**

---



## 9 Appendix

### 9.1 How to enter text on your machine

When you must enter text on your machine, a keyboard appears on the LCD.

- The characters that are available may differ depending on your country.
- The keyboard layout may differ depending on the operation you perform.



**(bizhub 4221i)** Press to cycle between letters, numbers, and special characters.

**(bizhub 5021i)** Press to select letters, numbers, and special characters.

Press to cycle between lowercase and uppercase letters.

To move the cursor to the left or right, press or .

Inserting spaces

- To enter a space, press [Space] or .

Making corrections

- If you entered a character incorrectly and want to change it, press or to move the cursor to the incorrect character, and then press . Enter the correct character.
- To insert a character, press or to move the cursor to the correct place, and then enter the character.
- Press for each character you want to erase, or press and hold to erase all the characters.

