



KONICA MINOLTA

# **bizhub 4422** USER'S GUIDE



# Contents

- Safety information..... 6**
  - Conventions..... 6
  - Product statements..... 6
  
- Learning about the printer..... 9**
  - Selecting a location for the printer..... 9
  - Printer configurations..... 10
  - Attaching cables..... 11
  - Using the control panel..... 13
  - Understanding the status of the sleep button and indicator light..... 13
  - Using the Embedded Web Server..... 14
  - Printing a menu settings page..... 14
  - Printing the Network Setup Page..... 14
  - Using the keyboard on the display..... 14
  
- Setting up and using the home screen applications..... 15**
  - Using the home screen..... 15
  - Customizing the home screen..... 16
  - Using Display Customization..... 16
  - Managing contacts..... 17
  
- Loading paper and specialty media..... 19**
  - Setting the size and type of the specialty media..... 19
  - Configuring Universal paper settings..... 19
  - Loading trays..... 19
  - Loading the multipurpose feeder..... 21
  - Linking trays..... 22
  
- Supported paper..... 23**
  - Supported paper sizes..... 23
  - Supported paper types..... 25
  - Supported paper weights..... 25
  
- Printing..... 26**
  - Printing from a computer..... 26

Printing from a mobile device..... 26

Printing from a flash drive.....27

Supported flash drives and file types..... 28

Configuring confidential jobs..... 29

Printing a font sample list.....29

Printing a directory list..... 29

Canceling a print job..... 29

**Copying.....31**

Making copies..... 31

Copying photos.....31

Copying on letterhead..... 31

Copying on both sides of the paper (two-sided).....31

Reducing or enlarging copies..... 32

Collating copies..... 32

Placing separator sheets between copies..... 32

Copying multiple pages onto a single sheet..... 32

Creating a copy shortcut..... 32

**E-mailing..... 33**

Setting up the e-mail function..... 33

Configuring e-mail settings..... 33

Sending an e-mail..... 33

Creating an e-mail shortcut.....34

**Faxing.....35**

Setting up the printer to fax..... 35

Sending a fax..... 48

Scheduling a fax..... 49

Creating a fax destination shortcut.....49

Changing the fax resolution..... 49

Adjusting the fax darkness..... 49

Viewing a fax log..... 49

Blocking junk faxes.....50

Holding faxes..... 50

Forwarding a fax.....50

<b>Scanning.....</b>	<b>51</b>
Scanning to an FTP server.....	51
Creating an FTP shortcut.....	51
Scanning to a flash drive.....	51
Sending scanned documents to a computer.....	52
<b>Understanding the printer menus.....</b>	<b>53</b>
Menu map.....	53
Device.....	54
Print.....	63
Paper.....	72
Copy.....	74
Fax.....	78
E-mail.....	90
FTP.....	97
USB Drive.....	102
Network/Ports.....	107
Security.....	119
Reports.....	127
Help.....	128
Troubleshooting.....	129
<b>Securing the printer.....</b>	<b>130</b>
Locating the security slot.....	130
Erasing printer memory.....	130
Erasing printer hard disk memory.....	130
Configuring printer hard disk encryption.....	131
Restoring factory default settings.....	131
Statement of Volatility.....	131
<b>Maintaining the printer.....</b>	<b>133</b>
Networking.....	133
Cleaning printer parts.....	135
Ordering parts and supplies.....	138
Replacing parts and supplies.....	139
Moving the printer.....	150



Saving energy and paper..... 151

**Clearing jams..... 153**

Avoiding jams.....153

Identifying jam locations..... 154

Paper jam in the front door..... 155

Paper jam in the rear door.....158

Paper jam in the standard bin.....159

Paper jam in the duplex unit..... 160

Paper jam in trays..... 161

Paper jam in the multipurpose feeder.....161

Paper jam in the automatic document feeder.....162

**Troubleshooting..... 164**

Network connection problems..... 164

Internal option problems.....166

Paper feed problems.....167

Printing problems.....169

Faxing problems..... 198

Scanning problems..... 201

Contacting customer support.....205

**Upgrading and migrating.....206**

Hardware..... 206

Software..... 211

Firmware.....214

**Notices.....215**

**Index.....222**

# Safety information

## Conventions

**Note:** A *note* identifies information that could help you.

**Warning:** A *warning* identifies something that could damage the product hardware or software.

**CAUTION:** A *caution* indicates a potentially hazardous situation that could injure you.

Different types of caution statements include:



**CAUTION—POTENTIAL INJURY:** Indicates a risk of injury.



**CAUTION—SHOCK HAZARD:** Indicates a risk of electrical shock.



**CAUTION—HOT SURFACE:** Indicates a risk of burn if touched.



**CAUTION—TIPPING HAZARD:** Indicates a crush hazard.



**CAUTION—PINCH HAZARD:** Indicates a risk of being caught between moving parts.

## Product statements



**CAUTION—POTENTIAL INJURY:** To avoid the risk of fire or electrical shock, connect the power cord to an appropriately rated and properly grounded electrical outlet that is near the product and easily accessible.



**CAUTION—POTENTIAL INJURY:** To avoid the risk of fire or electrical shock, use only the power cord provided with this product or the manufacturer's authorized replacement.



**CAUTION—POTENTIAL INJURY:** Do not use this product with extension cords, multioutlet power strips, multioutlet extenders, or UPS devices. The power capacity of these types of accessories can be easily overloaded by a laser printer and may result in a risk of fire, property damage, or poor printer performance.



**CAUTION—POTENTIAL INJURY:** To reduce the risk of fire, use only a 26 AWG or larger telecommunications (RJ-11) cord when connecting this product to the public switched telephone network. For users in Australia, the cord must be approved by the Australian Communications and Media Authority.



**CAUTION—SHOCK HAZARD:** To avoid the risk of electrical shock, do not place or use this product near water or wet locations.





**CAUTION—SHOCK HAZARD:** To avoid the risk of electrical shock, do not set up this product or make any electrical or cabling connections, such as the power cord, fax feature, or telephone, during a lightning storm.





**CAUTION—POTENTIAL INJURY:** Do not cut, twist, bind, crush, or place heavy objects on the power cord. Do not subject the power cord to abrasion or stress. Do not pinch the power cord between objects such as furniture and walls. If any of these things happen, a risk of fire or electrical shock results. Inspect the power cord regularly for signs of such problems. Remove the power cord from the electrical outlet before inspecting it.

 **CAUTION—SHOCK HAZARD:** To avoid the risk of electrical shock, make sure that all external connections (such as Ethernet and telephone system connections) are properly installed in their marked plug-in ports.

 **CAUTION—SHOCK HAZARD:** To avoid the risk of electrical shock, if you are accessing the controller board or installing optional hardware or memory devices sometime after setting up the printer, then turn the printer off, and unplug the power cord from the electrical outlet before continuing. If you have any other devices attached to the printer, then turn them off as well, and unplug any cables going into the printer.

 **CAUTION—SHOCK HAZARD:** To avoid the risk of electrical shock, do not use the fax feature during a lightning storm.

 **CAUTION—SHOCK HAZARD:** To avoid the risk of electrical shock when cleaning the exterior of the printer, unplug the power cord from the electrical outlet and disconnect all cables from the printer before proceeding.

 **CAUTION—POTENTIAL INJURY:** If the printer weight is greater than 18 kg (40 lb), then it requires two or more trained personnel to lift it safely.

 **CAUTION—POTENTIAL INJURY:** When moving the printer, follow these guidelines to avoid personal injury or printer damage:

- Make sure that all doors and trays are closed.
- Turn off the printer, and then unplug the power cord from the electrical outlet.
- Disconnect all cords and cables from the printer.
- If the printer has separate floor-standing optional trays or output options attached to it, then disconnect them before moving the printer.
- If the printer has a caster base, then carefully roll it to the new location. Use caution when passing over thresholds and breaks in flooring.
- If the printer does not have a caster base but is configured with optional trays or output options, then remove the output options and lift the printer off the trays. Do not try to lift the printer and any options at the same time.
- Always use the handholds on the printer to lift it.
- Any cart used to move the printer must have a surface able to support the full footprint of the printer.
- Any cart used to move the hardware options must have a surface able to support the dimensions of the options.
- Keep the printer in an upright position.
- Avoid severe jarring movements.
- Make sure that your fingers are not under the printer when you set it down.
- Make sure that there is adequate clearance around the printer.

 **CAUTION—TIPPING HAZARD:** Installing one or more options on your printer or MFP may require a caster base, furniture, or other feature to prevent instability causing possible injury. For more information on supported configurations, contact the place where you purchased the printer.

 **CAUTION—TIPPING HAZARD:** To reduce the risk of equipment instability, load each tray separately. Keep all other trays closed until needed.

 **CAUTION—HOT SURFACE:** The inside of the printer might be hot. To reduce the risk of injury from a hot component, allow the surface to cool before touching it.

 **CAUTION—PINCH HAZARD:** To avoid the risk of a pinch injury, use caution in areas marked with this label. Pinch injuries may occur around moving parts, such as gears, doors, trays, and covers.

 **CAUTION—POTENTIAL INJURY:** This product uses a laser. Use of controls or adjustments or performance of procedures other than those specified in the *User's Guide* may result in hazardous radiation exposure.

 **CAUTION—POTENTIAL INJURY:** The lithium battery in this product is not intended to be replaced. There is a danger of explosion if a lithium battery is incorrectly replaced. Do not recharge, disassemble, or incinerate a lithium battery. Discard used lithium batteries according to the manufacturer's instructions and local regulations.

This product is designed, tested, and approved to meet strict global safety standards with the use of specific manufacturer's components. The safety features of some parts may not always be obvious. The manufacturer is not responsible for the use of other replacement parts.

Refer service or repairs, other than those described in the user documentation, to a service representative.

This product uses a printing process that heats the print media, and the heat may cause the media to release emissions. You must understand the section in your operating instructions that discusses the guidelines for selecting print media to avoid the possibility of harmful emissions.

This product may produce small amounts of ozone during normal operation, and may be equipped with a filter designed to limit ozone concentrations to levels well below the recommended exposure limits. To avoid high ozone concentration levels during extensive usage, install this product in a well-ventilated area and replace the ozone and exhaust filters if instructed to do so in the product maintenance instructions. If there are no references to filters in the product maintenance instructions, then there are no filters requiring replacement for this product.

**SAVE THESE INSTRUCTIONS.**

# Learning about the printer

## Selecting a location for the printer

- Leave enough room to open trays, covers, and doors and to install hardware options.
- Set up the printer near an electrical outlet.

**⚠ CAUTION—POTENTIAL INJURY:** To avoid the risk of fire or electrical shock, connect the power cord to an appropriately rated and properly grounded electrical outlet that is near the product and easily accessible.

**⚡ CAUTION—SHOCK HAZARD:** To avoid the risk of electrical shock, do not place or use this product near water or wet locations.

- Make sure that airflow in the room meets the latest revision of the ASHRAE 62 standard or the CEN Technical Committee 156 standard.
- Provide a flat, sturdy, and stable surface.
- Keep the printer:
  - Clean, dry, and free of dust
  - Away from stray staples and paper clips
  - Away from the direct airflow of air conditioners, heaters, or ventilators
  - Free from direct sunlight and humidity extremes
- Observe the recommended temperatures and avoid fluctuations.

Ambient temperature	10 to 32°C (50 to 90°F)
Storage temperature	0 to 40°C (32 to 104°F)

- Allow the following recommended amount of space around the printer for proper ventilation:

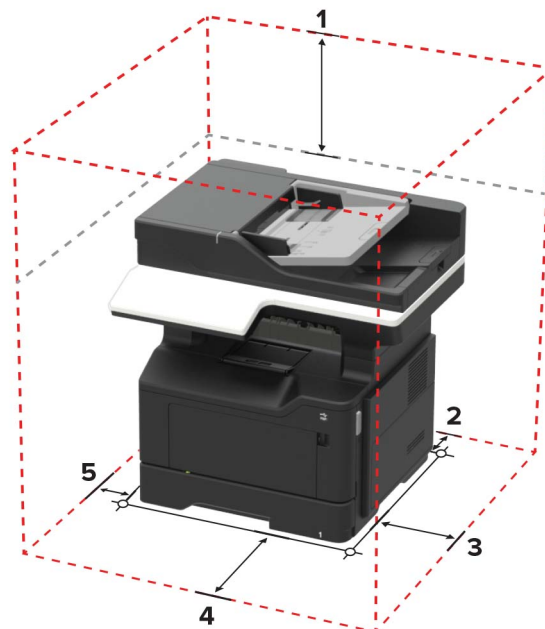

1	Top	737 mm (29 in.)
2	Rear	203 mm (8 in.)
3	Right side	305 mm (12 in.)
4	Front	510 mm (20 in.)
5	Left side	203 mm (8 in.)

## Printer configurations

**CAUTION—TIPPING HAZARD:** Installing one or more options on your printer or MFP may require a caster base, furniture, or other feature to prevent instability causing possible injury. For more information on supported configurations, contact the place where you purchased the printer.

**CAUTION—TIPPING HAZARD:** To reduce the risk of equipment instability, load each tray separately. Keep all other trays closed until needed.



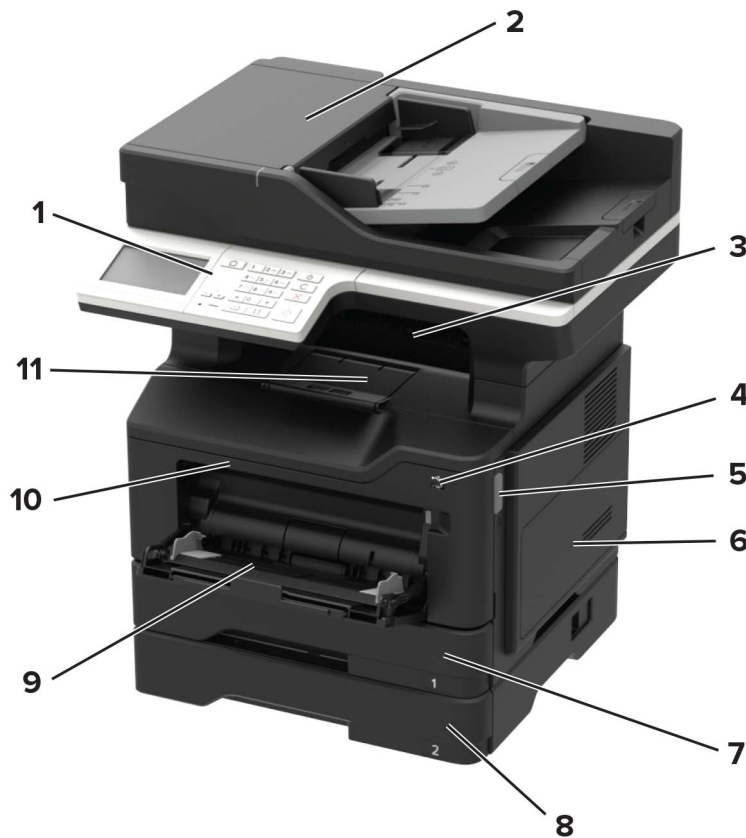

You can configure your printer by adding optional 250- or 550-sheet trays. For more information, see [“Installing optional trays” on page 210](#).



1	Control panel
2	Automatic document feeder (ADF)

<b>3</b>	Standard bin
<b>4</b>	Front USB
<b>5</b>	Front door release button
<b>6</b>	Controller board access cover
<b>7</b>	Standard 250-sheet tray
<b>8</b>	Optional 250- or 550-sheet tray
<b>9</b>	100-sheet multipurpose feeder
<b>10</b>	Front door
<b>11</b>	Paper stopper

## Attaching cables

-  **CAUTION—POTENTIAL INJURY:** To avoid the risk of fire or electrical shock, connect the power cord to an appropriately rated and properly grounded electrical outlet that is near the product and easily accessible.
-  **CAUTION—POTENTIAL INJURY:** To avoid the risk of fire or electrical shock, use only the power cord provided with this product or the manufacturer's authorized replacement.
-  **CAUTION—POTENTIAL INJURY:** To avoid the risk of electrical shock, do not set up this product or make any electrical or cabling connections, such as the power cord, fax feature, or telephone, during a lightning storm.
-  **CAUTION—POTENTIAL INJURY:** To reduce the risk of fire, use only a 26 AWG or larger telecommunications (RJ-11) cord when connecting this product to the public switched telephone network. For users in Australia, the cord must be approved by the Australian Communications and Media Authority.

**Warning—Potential Damage:** To avoid loss of data or printer malfunction, do not touch the USB cable, any wireless network adapter, or the printer in the areas shown while actively printing.

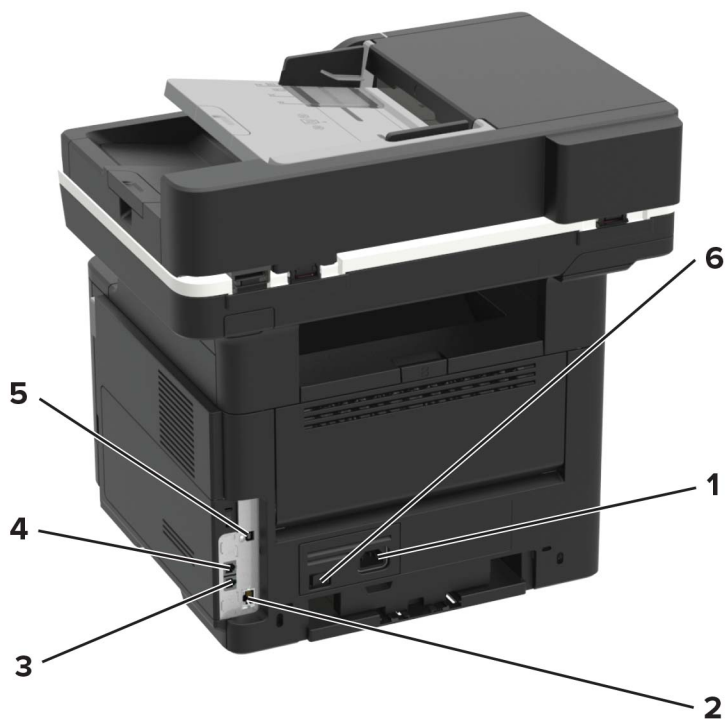

	Use the	To
1	Power cord socket	Connect the printer to an electrical outlet.
2	Ethernet port*	Connect the printer to an Ethernet network.
3	LINE port	Connect the printer to an active telephone line through a standard wall jack (RJ-11), DSL filter, or VoIP adapter, or any other adapter that allows you to access the telephone line to send and receive faxes.
4	EXT port	Connect additional devices (telephone or answering machine) to the printer and the telephone line. Use this port if you do not have a dedicated fax line for the printer and if this connection method is supported in your country or region. <b>Note:</b> Remove the plug to access the port.
5	USB printer port*	Connect the printer to a computer.
6	Power switch	Turn on or turn off the printer.

\* This network port is activated when a cable is inserted into the port.



## Using the control panel

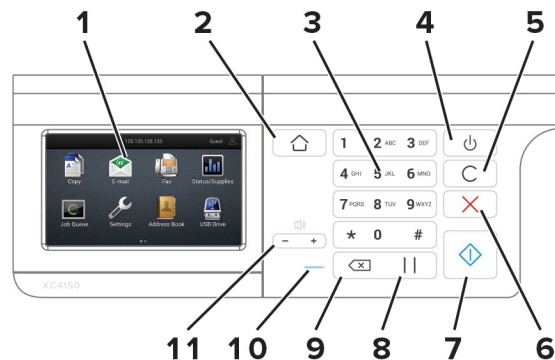

	Use the	To
1	Display	<ul style="list-style-type: none"> <li>View the printer messages and supply status.</li> <li>Set up and operate the printer.</li> </ul>
2	Home button	Go to the home screen.
3	Numeric keypad	Enter numbers or symbols in an input field.
4	Sleep button	Enable Sleep mode <b>Note:</b> To enable Sleep mode, press the button twice.
5	Clear all or Reset button	Reset the default settings of a function such as copying, faxing, or scanning.
6	Stop or Cancel button	Stop the current printer task.
7	Start button	Start a printer task, depending on which mode is selected.
8	Pause button	Place a dial pause in a fax number.
9	Backspace button	Move the cursor backward and delete a character in an input field.
10	Indicator light	Check the printer status.
11	Volume buttons	Adjust the speaker volume.

## Understanding the status of the sleep button and indicator light

Indicator light	Printer status
Off	The printer is off or in Hibernate mode.
Blue	The printer is ready or processing data.
Red	The printer requires user intervention.

Sleep button light	Printer status
Off	The printer is off, ready, or processing data.
Solid amber	The printer is in Sleep mode.
Blinking amber	The printer is in Hibernate mode.

## Using the Embedded Web Server

**Note:** This functionality is available only in network printers or printers connected to print servers.

Use the Embedded Web Server to:

- Check printer supplies status.
- Configure supply notifications.
- Configure printer settings.
- Configure network settings.
- View reports.

To access the Embedded Web Server for your printer:

- 1 Obtain the printer IP address by printing the network setup page or menu settings page, and then finding the TCP/IP section.

For more information, see [“Printing the Network Setup Page” on page 14](#).

**Notes:**

- The IP address appears as four sets of numbers separated by periods, such as 123.123.123.123.
- If you are using a proxy server, then temporarily disable it to load the web page correctly.

- 2 Open a web browser, and then type the printer IP address in the address field.

- 3 Press **Enter**.

## Printing a menu settings page

From the home screen, touch **Settings > Reports > Menu Settings Page**.

## Printing the Network Setup Page

From the home screen, touch **Settings > Reports > Network > Network Setup Page**.

## Using the keyboard on the display

Do one or more of the following:

- Drag a finger over the key to announce the character.
- Lift the finger to enter or type the character in the field.
- Press **Backspace** to delete characters.
- To hear the content in the input field, press **Tab**, and then press **Shift + Tab**.

# Setting up and using the home screen applications

## Using the home screen

**Note:** Your home screen may vary depending on your home screen customization settings, administrative setup, and active embedded solutions.



Touch		To
1	Copy	Make copies.
2	E-mail	Send e-mails.
3	Fax	Send fax.
4	Status/Supplies	<ul style="list-style-type: none"> <li>Show a printer warning or error message whenever the printer requires intervention to continue processing.</li> <li>View more information on the printer warning or message, and on how to clear it.</li> </ul> <p><b>Note:</b> You can also access this setting by touching the top section of the home screen.</p>

Touch		To
5	USB Drive	<ul style="list-style-type: none"> <li>View, select, or print photos and documents from a flash drive.</li> <li>Scan photos and documents to a flash drive.</li> </ul>
6	Address Book	Access, create, and organize contacts.
7	Settings	Access the printer menus.
8	Job Queue	Show all the current print jobs. <b>Note:</b> You can also access this setting by touching the top section of the home screen.
9	Held Jobs	Show the print jobs that are held in the printer memory.
10	FTP	Scan and save documents directly to an FTP server.
11	Scan Center	Send scanned documents to one or more destinations.
12	Shortcut Center	Organize all shortcuts.

## Customizing the home screen

1 Open a web browser, and then type the printer IP address in the address field.

### Notes:

- View the printer IP address on the printer home screen. The IP address appears as four sets of numbers separated by periods, such as 123.123.123.123.
- If you are using a proxy server, then temporarily disable it to load the web page correctly.

2 Click **Settings > Device > Visible Home Screen Icons**.

3 Select the icons that you want to appear on the home screen.

4 Apply the changes.

## Using Display Customization

Before using the application, make sure to do the following:

- Access the Embedded Web Server, and then configure the application.
- Enable and configure Slideshow Settings and Wallpaper Settings.

### Changing the wallpaper image

1 From the home screen, touch **Change Wallpaper**.

2 Select an image to use.

3 Apply the changes.

### Running a slide show from a flash drive

1 Insert a flash drive into the USB port.

2 From the home screen, touch **Slideshow**.

Images appear in alphabetical order.

**Note:** You can remove the flash drive after the slide show starts, but the images are not stored in the printer. If the slide show stops, then insert the flash drive again to view the images.

## Managing contacts

### Adding contacts

- 1 Open a web browser, and then type the printer IP address in the address field.

**Notes:**

- View the printer IP address on the printer home screen. The IP address appears as four sets of numbers separated by periods, such as 123.123.123.123.
- If you are using a proxy server, then temporarily disable it to load the web page correctly.

- 2 Click **Address Book**.

- 3 From the Contacts section, add a contact.

**Note:** You can assign the contact to one or more groups.

- 4 If necessary, specify a login method to allow application access.
- 5 Apply the changes.

### Adding groups

- 1 Open a web browser, and then type the printer IP address in the address field.

**Notes:**

- View the printer IP address on the printer home screen. The IP address appears as four sets of numbers separated by periods, such as 123.123.123.123.
- If you are using a proxy server, then temporarily disable it to load the web page correctly.

- 2 Click **Address Book**.

- 3 From the Contact Groups section, add a group name.

**Note:** You can assign one or more contacts to the group.

- 4 Apply the changes.

### Editing contacts or groups

- 1 Open a web browser, and then type the printer IP address in the address field.

**Notes:**

- View the printer IP address on the printer home screen. The IP address appears as four sets of numbers separated by periods, such as 123.123.123.123.
- If you are using a proxy server, then temporarily disable it to load the web page correctly.

- 2 Click **Address Book**.

**3** Do either of the following:

- From the Contacts section, click a contact name, and then edit the information.
- From the Contact Groups section, click a group name, and then edit the information.

**4** Apply the changes.

## Deleting contacts or groups

**1** Open a web browser, and then type the printer IP address in the address field.

**Notes:**

- View the printer IP address on the printer home screen. The IP address appears as four sets of numbers separated by periods, such as 123.123.123.123.
- If you are using a proxy server, then temporarily disable it to load the web page correctly.

**2** Click **Address Book**.

**3** Do either of the following:

- From the Contacts section, select a contact that you want to delete.
- From the Contact Groups section, select a group name that you want to delete.

# Loading paper and specialty media

## Setting the size and type of the specialty media

The trays automatically detect the size of plain paper. For specialty media like labels, card stock, or envelopes, do the following:

- 1 From the home screen, navigate to:  
**Settings > Paper > Tray Configuration > Paper Size/Type** > select a paper source
- 2 Set the size and type of the specialty media.

## Configuring Universal paper settings

- 1 From the home screen, touch **Settings > Paper > Media Configuration > Universal Setup**.
- 2 Configure the settings.

## Loading trays

 **CAUTION—TIPPING HAZARD:** To reduce the risk of equipment instability, load each tray separately. Keep all other trays closed until needed.

- 1 Remove the tray.

**Note:** To avoid paper jams, do not remove trays while the printer is busy.

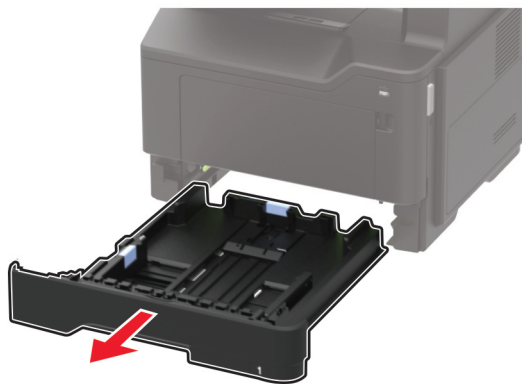

- 2** Adjust the paper guides to match the size of the paper that you are loading.

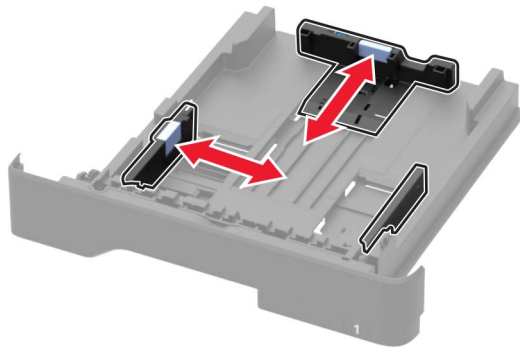

- 3** Flex, fan, and align the paper edges before loading.

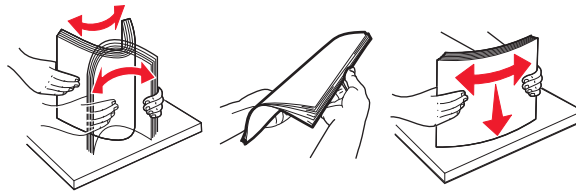

- 4** Load the paper stack with the printable side facedown, and then make sure that the side guides fit snugly against the paper.

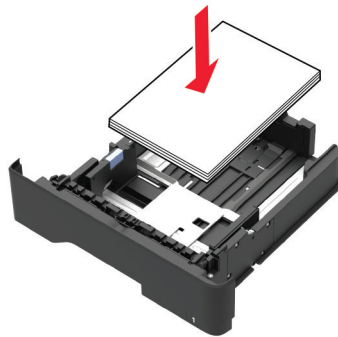

**Notes:**

- Load letterhead facedown with the top edge of the sheet toward the front of the tray for one-sided printing.
- Load letterhead faceup with the bottom edge of the sheet toward the front of the tray for two-sided printing.
- Do not slide paper into the tray.
- To avoid paper jams, make sure that the stack height is below the maximum paper fill indicator.

- 5** Insert the tray.

If necessary, set the paper size and paper type from the control panel to match the paper loaded.



## Loading the multipurpose feeder

1 Open the multipurpose feeder.

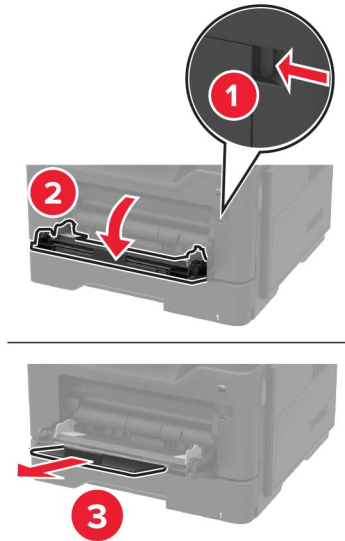

2 Adjust the guide to match the size of the paper that you are loading.

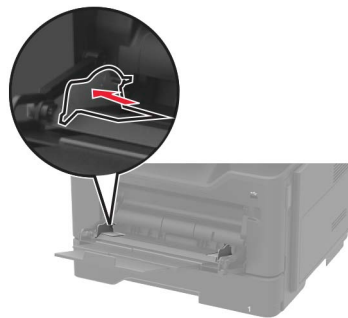

3 Flex, fan, and align the paper edges before loading.

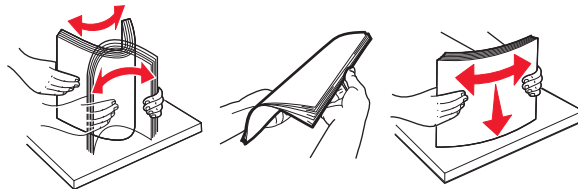

4 Load paper with the printable side faceup.

### Notes:

- Load letterhead faceup with the top edge of the sheet toward the front of the tray for one-sided printing.
- Load letterhead facedown with the bottom edge of the sheet toward the front of the tray for two-sided printing.
- Load envelopes with the flap facedown on the left side.

- Load European envelopes with the flap facedown and entering the printer first.

**Warning—Potential Damage:** Do not use envelopes with stamps, clasps, snaps, windows, coated linings, or self-stick adhesives.

- 5 From the control panel, set the paper size and paper type to match the paper loaded.

## Linking trays

- 1 Open a web browser, and then type the printer IP address in the address field.

**Notes:**

- View the printer IP address on the printer home screen. The IP address appears as four sets of numbers separated by periods, such as 123.123.123.123.
- If you are using a proxy server, then temporarily disable it to load the web page correctly.

- 2 Click **Settings > Paper > Tray Configuration**.

- 3 Set the same paper size and paper type for the trays that you are linking.

- 4 Save the settings.

**Note:** You can also change the settings from the printer control panel.

To unlink trays, make sure that no trays have the same paper size and paper type settings.

**Warning—Potential Damage:** The temperature of the fuser varies according to the specified paper type. To avoid printing issues, match the paper type setting in the printer with the paper loaded in the tray.

## Supported paper

### Supported paper sizes

Paper size	Tray	Multipurpose feeder	Two-sided printing	ADF	Scanner glass
<b>A4</b> 210 x 297 mm (8.3 x 11.7 in.)	✓	✓	✓	✓	✓
<b>A5</b> 210 x 148 mm (5.8 x 8.3 in.)	✓	✓	x	✓	✓
<b>A5 LEF*</b> 148 x 210 mm (5.8 x 8.3 in.)	✓	✓	x	✓	✓
<b>A6*</b> 105 x 148 mm (4.1 x 5.8 in.)	✓	✓	x	✓	✓
<b>JIS B5</b> 182 x 257 mm (7.2 x 10.1 in.)	✓	✓	x	✓	✓
<b>Oficio (Mexico)</b> 216 x 340 mm (8.5 x 13.4 in.)	✓	✓	✓	✓	✓
<b>Hagaki</b> 100 x 148 mm (3.9 x 5.8 in.)	x	✓	x	x	✓
<b>Business card</b> 50.8 x 88.9 mm (2 x 3.5 in.)	x	x	x	x	✓
<b>Statement</b> 140 x 216 mm (5.5 x 8.5 in.)	✓	✓	x	✓	✓
<b>Executive</b> 184 x 267 mm (7.3 x 10.5 in.)	✓	✓	x	✓	✓
<b>Letter</b> 216 x 279 mm (8.5 x 11 in.)	✓	✓	✓	✓	✓

\* This paper size is not supported in the optional tray.

Paper size	Tray	Multipurpose feeder	Two-sided printing	ADF	Scanner glass
<b>Legal</b> 216 x 356 mm (8.5 x 14 in.)	✓	✓	✓	✓	✓
<b>Folio</b> 216 x 330 mm (8.5 x 13 in.)	✓	✓	✓	✓	✓
<b>Universal</b> 76.2 x 127 mm to 216 x 356 mm (3 x 5 in. to 8.5 x 14 in.)	✓	✓	x	✓	✓
<b>7 3/4 Envelope (Monarch)</b> 98 x 191 mm (3.9 x 7.5 in.)	x	✓	x	x	✓
<b>9 Envelope</b> 98 x 225 mm (3.9 x 8.9 in.)	x	✓	x	x	✓
<b>10 Envelope</b> 105 x 241 mm (4.1 x 9.5 in.)	x	✓	x	x	✓
<b>DL Envelope</b> 110 x 220 mm (4.3 x 8.7 in.)	x	✓	x	x	✓
<b>C5 Envelope</b> 162 x 229 mm (6.4 x 9 in.)	x	✓	x	x	✓
<b>B5 Envelope</b> 176 x 250 mm (6.9 x 9.8 in.)	x	✓	x	x	✓
<b>Other Envelope</b> 76.2 x 127 mm to 216 x 356 mm (3 x 5 in. to 8.5 x 14 in.)	x	✓	x	x	✓

\* This paper size is not supported in the optional tray.

## Supported paper types

Paper type	Tray	Multipurpose feeder	Two-sided printing	ADF	Scanner glass
Plain paper	✓	✓	✓	✓	✓
Card stock	X	✓	X	X	✓
Transparency	✓	✓	X	X	✓
Recycled	✓	✓	✓	✓	✓
Paper labels <sup>1</sup>	✓	✓	X	X	✓
Bond <sup>2</sup>	✓	✓	✓	✓	✓
Letterhead	✓	✓	✓	✓	✓
Preprinted	✓	✓	✓	✓	✓
Colored Paper	✓	✓	✓	✓	✓
Light Paper	✓	✓	✓	✓	✓
Heavy Paper <sup>2</sup>	✓	✓	✓	✓	✓
Rough/Cotton	✓	✓	✓	✓	✓
Envelope	X	✓	X	X	✓
Rough envelope	X	✓	X	X	✓

<sup>1</sup> One-sided paper labels designed for laser printers are supported for occasional use. It is recommended to print 20 or fewer pages of paper labels per month. Vinyl, pharmacy, and two-sided labels are not supported.

<sup>2</sup> Bond and Heavy Paper are supported in two-sided printing up to 90-g/m<sup>2</sup> (24-lb) paper weight.

## Supported paper weights

	Tray	Multipurpose feeder	Two-sided printing	ADF
Paper weight	60–120 g/m <sup>2</sup> (16–32 lb)	60–216 g/m <sup>2</sup> (16–58 lb)	60–90 g/m <sup>2</sup> (16–24 lb)	52–120 g/m <sup>2</sup> (14–32 lb)

# Printing

## Printing from a computer

**Note:** For labels, card stock, and envelopes, set the paper size and paper type in the printer before printing the document.

- 1 From the document that you are trying to print, open the Print dialog.
- 2 If necessary, adjust the settings.
- 3 Print the document.

**Note:** For details of the function of the printer driver, refer to the Help of the printer driver.

## Printing from a mobile device

### Printing from a mobile device using Google Cloud Print

Google Cloud Print™ is a mobile printing service that allows enabled applications on mobile devices to print to any Google Cloud Print-ready printer.

- 1 From the home screen of your mobile device, launch an enabled application.
- 2 Tap **Print**, and then select a printer.
- 3 Print the document.

### Printing from a mobile device using Mopria Print Service

Mopria® Print Service is a mobile printing solution for mobile devices running on Android version 4.4 or later. It allows you to print directly to any Mopria-certified printer.

**Note:** Before printing, make sure that the Mopria Print Service is enabled.

- 1 From the home screen of your mobile device, launch a compatible application.
- 2 Tap **Print**, and then select a printer.
- 3 Print the document.

### Printing from a mobile device using AirPrint

AirPrint is a mobile printing solution that allows you to print directly from Apple devices to an AirPrint-certified printer.

**Note:** This application is supported only in some Apple devices.

- 1 From the home screen of your mobile device, launch a compatible application.
- 2 Select an item to print, and then tap the share icon.

- 3 Tap **Print**, and then select the printer.
- 4 Send the print job.

## Printing from a flash drive

- 1 Insert the flash drive.



### Notes:

- If you insert the flash drive when an error message appears, then the printer ignores the flash drive.
- If you insert the flash drive while the printer is processing other print jobs, then **Busy** appears on the display.

- 2 From the display, touch the document that you want to print.  
If necessary, configure other print settings.

- 3 Send the print job.

To print another document, touch **USB Drive**.

**Warning—Potential Damage:** To avoid loss of data or printer malfunction, do not touch the flash drive or the printer in the area shown while actively printing, reading, or writing from the memory device.



## Supported flash drives and file types

### Flash drives

#### Notes:

- The printer supports high-speed USB flash drives with full-speed standard.
- USB flash drives must support the File Allocation Table (FAT) system.

Many flash drives are tested and approved for use with the printer. For more information, contact the place where you purchased the printer.

### File types

#### Documents:

- .doc or .docx
- .xls or .xlsx
- .ppt or .pptx
- .pdf
- .xps

#### Images:

- .dcx
- .gif
- .jpeg or .jpg
- .bmp
- .pcx
- .tiff or .tif
- .png



## Configuring confidential jobs

- 1 From the home screen, touch **Settings > Security > Confidential Print Setup**.
- 2 Configure the settings.

Use	To
Max Invalid PIN	Limit the number of times an invalid PIN can be entered. <b>Note:</b> When the limit is reached, the print jobs for that user name are deleted.
Confidential Job Expiration	Set the amount of time before confidential jobs are automatically deleted from the printer memory. <b>Note:</b> Confidential held jobs are stored in the printer until you log in and release or delete them manually.
Repeat Job Expiration	Set the amount of time before repeat jobs are deleted from the printer memory. <b>Note:</b> Repeat held jobs are stored so extra copies can be printed later.
Verify Job Expiration	Set the amount of time before verify jobs are deleted from the printer memory. <b>Note:</b> Verify jobs print one copy to check if it is satisfactory before printing the remaining copies.
Reserve Job Expiration	Set the amount of time before reserved jobs are deleted without being printed. <b>Note:</b> Reserve held jobs are automatically deleted after printing.

## Printing a font sample list

- 1 From the home screen, touch **Settings > Reports > Print > Print Fonts**.
- 2 Touch **PCL Fonts** or **PostScript Fonts**.

## Printing a directory list

From the home screen, touch **Settings > Reports > Print > Print Directory**.

## Canceling a print job

### From the printer control panel

- 1 From the home screen, touch **Job Queue**.  
**Note:** You can also access this setting by touching the top section of the home screen.
- 2 Select the job to cancel.

### From the computer

- 1 Depending on the operating system, do either of the following:
  - Open the printers folder, and then select your printer.
  - From the System Preferences in the Apple menu, navigate to your printer.

**2** Select the job to cancel.

# Copying

## Making copies

- 1 Load an original document into the ADF tray or on the scanner glass.

**Note:** To avoid a cropped image, make sure that the original document and output have the same paper size.

- 2 From the home screen, touch **Copy**, and then specify the number of copies.

If necessary, adjust the copy settings.

- 3 Copy the document.

**Note:** To make a quick copy, from the control panel, press .

## Copying photos

- 1 Place a photo on the scanner glass.

- 2 From the home screen, navigate to:

**Copy > Content > Content Type > Photo**

- 3 In the Content Source menu, select the setting that best matches the original photo.

- 4 Copy the photo.

## Copying on letterhead

- 1 Load an original document into the ADF tray or on the scanner glass.

- 2 From the home screen, touch **Copy**, and then specify the size of the original document.

- 3 Touch **Copy to**, and then select the tray that contains the specialty media.

If you are loading the specialty media into the multipurpose feeder, then navigate to:

**Multipurpose Feeder > select the size of the specialty media > Letterhead**

- 4 Send the copy job.

## Copying on both sides of the paper (two-sided)

- 1 Load an original document into the ADF tray or on the scanner glass.

- 2 From the home screen, touch **Copy > Settings > Paper Setup**.

- 3 Adjust the settings.

- 4 Copy the document.

## Reducing or enlarging copies

- 1 Load an original document into the ADF tray or on the scanner glass.
- 2 From the home screen, navigate to:  
**Copy** > **Scale** > specify a scale value  
**Note:** Changing the size of the original document or output after setting Scale restores the scale value to Auto.
- 3 Copy the document.

## Collating copies

- 1 Load an original document into the ADF tray or on the scanner glass.
- 2 From the home screen, touch **Copy**, and then set Collate to **On**.
- 3 Copy the document.

## Placing separator sheets between copies

- 1 Load an original document into the ADF tray or on the scanner glass.
- 2 From the home screen, touch **Copy** > **Separator Sheets**.
- 3 Adjust the settings.
- 4 Send the copy job.

## Copying multiple pages onto a single sheet

- 1 Load an original document into the ADF tray or on the scanner glass.
- 2 From the home screen, touch **Copy** > **Pages per Side**.
- 3 Adjust the settings.
- 4 Copy the document.

## Creating a copy shortcut

- 1 From the home screen, touch **Copy**.
- 2 Adjust the settings, and then touch .
- 3 Enter a shortcut name.
- 4 Apply the changes.

# E-mailing

## Setting up the e-mail function

- 1 From the home screen, touch **Settings** > **Device** > **Preferences** > **Run Initial Setup**.
- 2 Turn off the printer, wait for about 10 seconds, and then turn it back on.
- 3 From the Before You Begin screen, select **Change the Settings and Continue with the Wizard**.
- 4 From the Fax/Email Server Setup screen, enter the needed information.
- 5 Finish the setup.

## Configuring e-mail settings

- 1 Open a Web browser, and then type the printer IP address in the address field.

**Notes:**

- View the printer IP address on the printer home screen. The IP address appears as four sets of numbers separated by periods, such as 123.123.123.123.
- If you are using a proxy server, then temporarily disable it to load the Web page correctly.

- 2 Click **Settings** > **E-mail**.
- 3 Enter the needed information.
- 4 Apply the changes.

## Sending an e-mail

### Using the control panel

- 1 Load an original document into the ADF tray or on the scanner glass.
- 2 From the home screen, touch **E-mail**, and then enter the needed information.

**Note:** You can also enter the recipient using the address book or shortcut number.
- 3 If necessary, configure the output file type settings.
- 4 Send the e-mail.

### Using the shortcut number

- 1 From the control panel, press **#**, and then enter the shortcut number using the keypad.
- 2 Send the e-mail.

## Creating an e-mail shortcut

- 1 From the home screen, touch **E-mail**.
- 2 Configure the settings, and then touch .
- 3 Enter a shortcut name.
- 4 Apply the changes.

# Faxing

## Setting up the printer to fax

### Notes:

- The following connection methods are applicable only in some countries or regions.
- During the initial printer setup, clear the fax function check box and any other function you plan to set up later, and then select **Continue**.
- If the fax function is enabled and not fully set up, then the indicator light may blink red.

**Warning—Potential Damage:** To avoid loss of data or printer malfunction, do not touch cables or the printer in the area shown while actively sending or receiving a fax.



## Setting up the fax function

- 1 From the home screen, touch **Settings** > **Device** > **Preferences** > **Run Initial Setup**.
- 2 Turn off the printer, wait for about 10 seconds, and then turn it back on.
- 3 From the Before You Begin screen, select **Change the Settings and Continue with the Wizard**.
- 4 From the Fax/Email Server Setup screen, enter the needed information.
- 5 Finish the setup.

## Setting up fax using a standard telephone line

 **CAUTION—SHOCK HAZARD:** To avoid the risk of electrical shock, do not set up this product or make any electrical or cabling connections, such as the power cord, fax feature, or telephone, during a lightning storm.

**⚠ CAUTION—SHOCK HAZARD:** To avoid the risk of electrical shock, do not use the fax feature during a lightning storm.

**⚠ CAUTION—POTENTIAL INJURY:** To reduce the risk of fire, use only a 26 AWG or larger telecommunications (RJ-11) cord when connecting this product to the public switched telephone network. For users in Australia, the cord must be approved by the Australian Communications and Media Authority.

### Setup 1: Printer is connected to a dedicated fax line

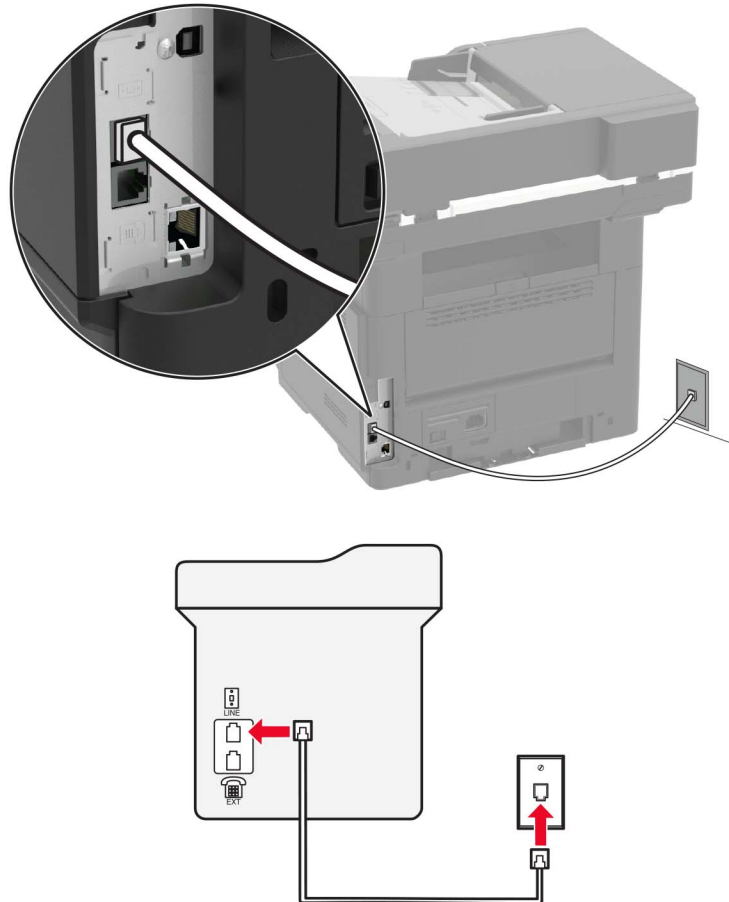

**1** Connect one end of the telephone cable to the line port of the printer.

**2** Connect the other end of the cable to an active analog wall jack.

#### Notes:

- You can set the printer to receive faxes automatically (Auto Answer On) or manually (Auto Answer Off).
- If you want to receive faxes automatically, then set the printer to pick up on a specified number of rings.

### Setup 2: Printer is sharing the line with an answering machine

**Note:** If you subscribe to a distinctive ring service, then make sure that you set the correct ring pattern for the printer. Otherwise, the printer does not receive faxes even if you have set it to receive faxes automatically.

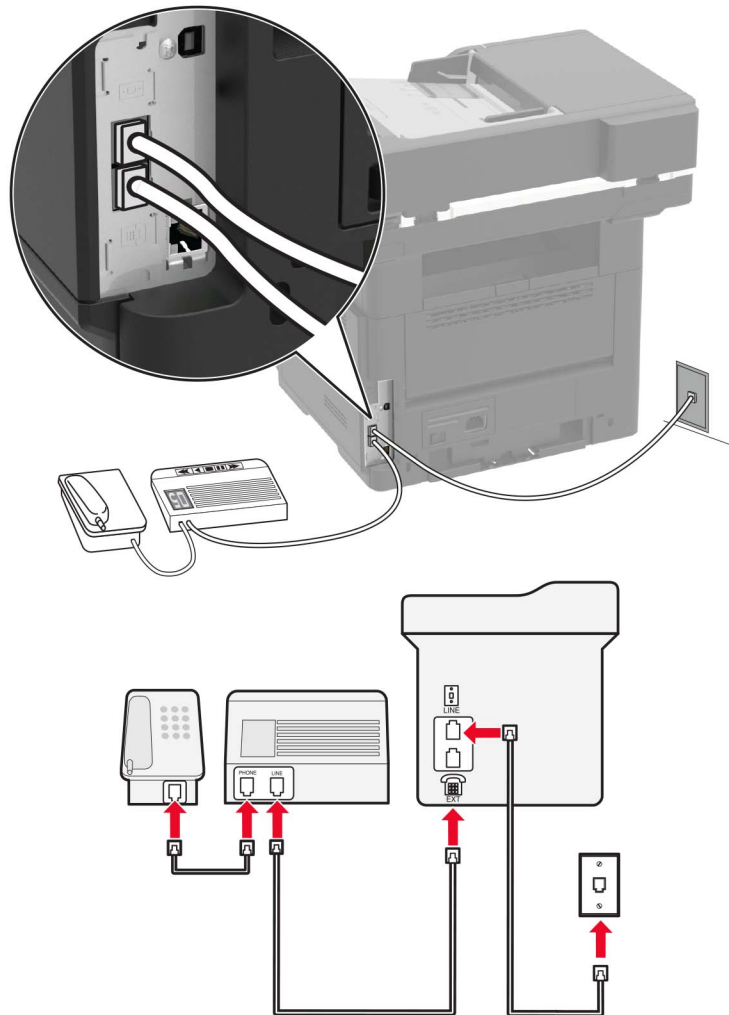

**Connected to the same telephone wall jack**

- 1** Connect one end of the telephone cable to the line port of the printer.
- 2** Connect the other end of the cable to an active analog wall jack.
- 3** Connect the answering machine to the telephone port of the printer.

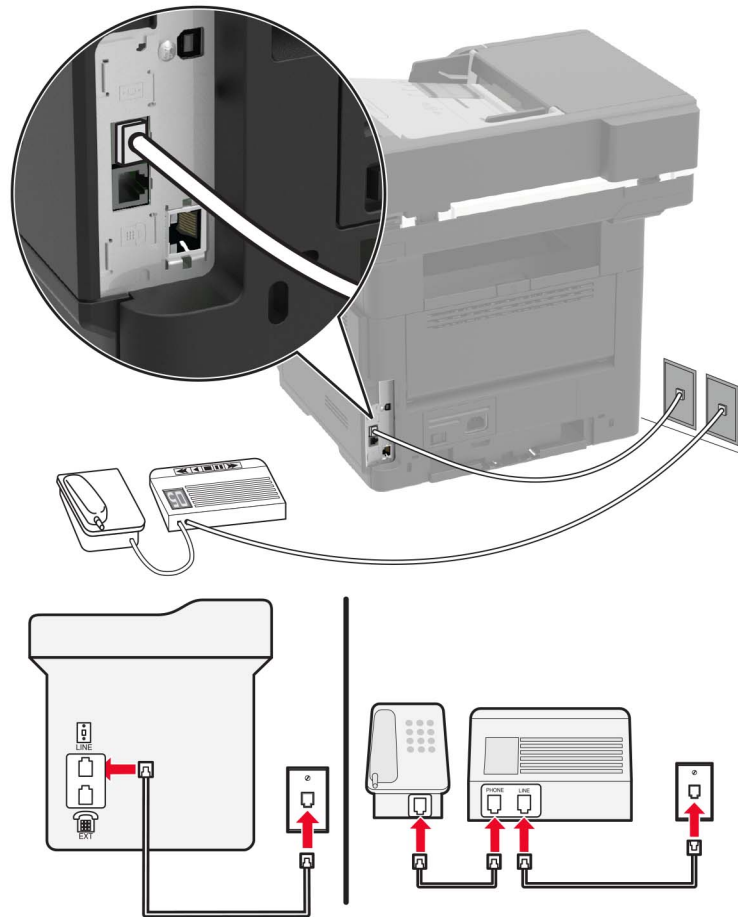
**Connected to different wall jacks**

- 1 Connect one end of the telephone cable to the line port of the printer.
- 2 Connect the other end of the cable to an active analog wall jack.

**Notes:**

- If you have only one telephone number on your line, then set the printer to receive faxes automatically.
- Set the printer to pick up calls two rings after the answering machine. For example, if the answering machine picks up calls after four rings, then set the printer Rings to Answer setting to six.

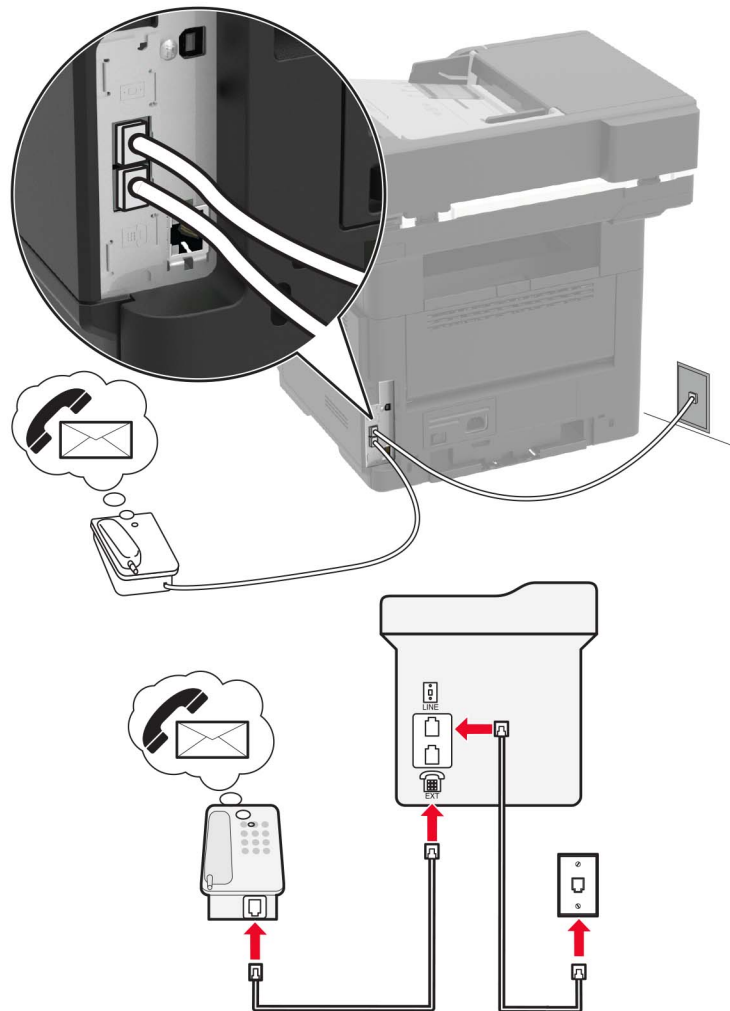

**Setup 3: Printer is sharing the line with a telephone subscribed to voice mail service**

- 1 Connect one end of the telephone cable to the line port of the printer.
- 2 Connect the other end of the cable to an active analog wall jack.
- 3 Connect the telephone to the telephone port of the printer.

**Notes:**

- This setup works best if you are using voice mail more often than fax, and if you subscribe to a distinctive ring service.
- When you answer the telephone and you hear fax tones, press **\*9\*** or the manual answer code on the telephone to receive the fax.
- You can also set the printer to receive faxes automatically, but turn off the voice mail service when you are expecting a fax.

## Setting up fax using digital subscriber line

-  **CAUTION—SHOCK HAZARD:** To avoid the risk of electrical shock, do not set up this product or make any electrical or cabling connections, such as the power cord, fax feature, or telephone, during a lightning storm.
-  **CAUTION—SHOCK HAZARD:** To avoid the risk of electrical shock, do not use the fax feature during a lightning storm.
-  **CAUTION—POTENTIAL INJURY:** To reduce the risk of fire, use only a 26 AWG or larger telecommunications (RJ-11) cord when connecting this product to the public switched telephone network. For users in Australia, the cord must be approved by the Australian Communications and Media Authority.

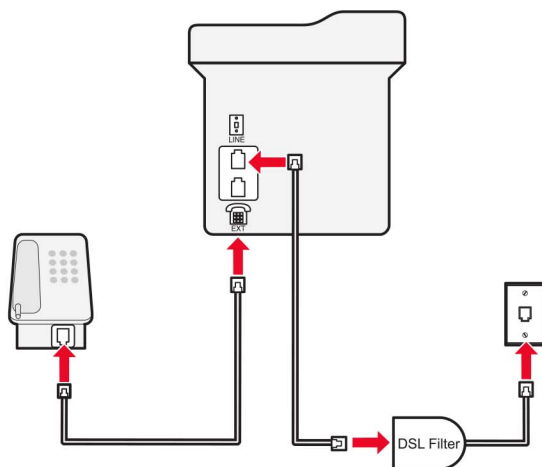
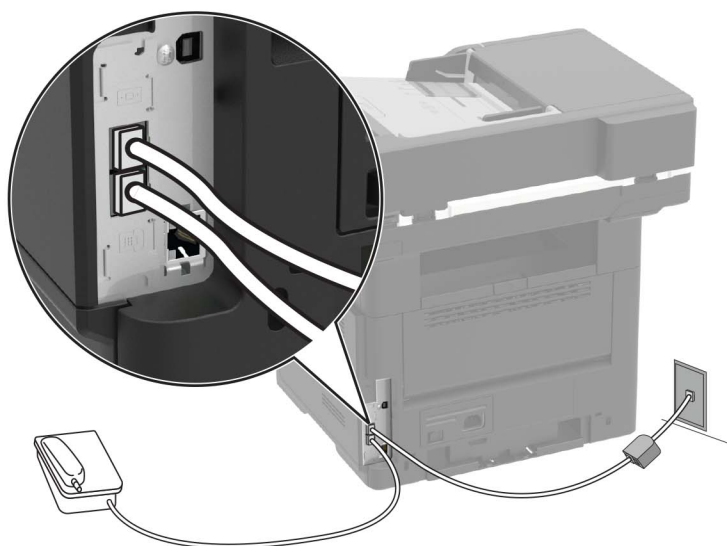



Digital subscriber line (DSL) splits your regular telephone line into two channels: voice and Internet. Telephone and fax signals travel through the voice channel, and Internet signals pass through the other channel.

To minimize interference between the two channels, ask for a DSL filter from your DSL provider.

- 1 Connect the line port of the DSL filter to the wall jack.
- 2 Connect one end of the telephone cable to the line port of the printer.
- 3 Connect the other end of the cable to the telephone port on the DSL filter.

**Note:** To connect a telephone to the printer, remove any installed adapter plug from the telephone port of the printer, and then connect the telephone.

## Setting up fax using VoIP telephone service

-  **CAUTION—SHOCK HAZARD:** To avoid the risk of electrical shock, do not set up this product or make any electrical or cabling connections, such as the power cord, fax feature, or telephone, during a lightning storm.
-  **CAUTION—SHOCK HAZARD:** To avoid the risk of electrical shock, do not use the fax feature during a lightning storm.
-  **CAUTION—POTENTIAL INJURY:** To reduce the risk of fire, use only a 26 AWG or larger telecommunications (RJ-11) cord when connecting this product to the public switched telephone network. For users in Australia, the cord must be approved by the Australian Communications and Media Authority.

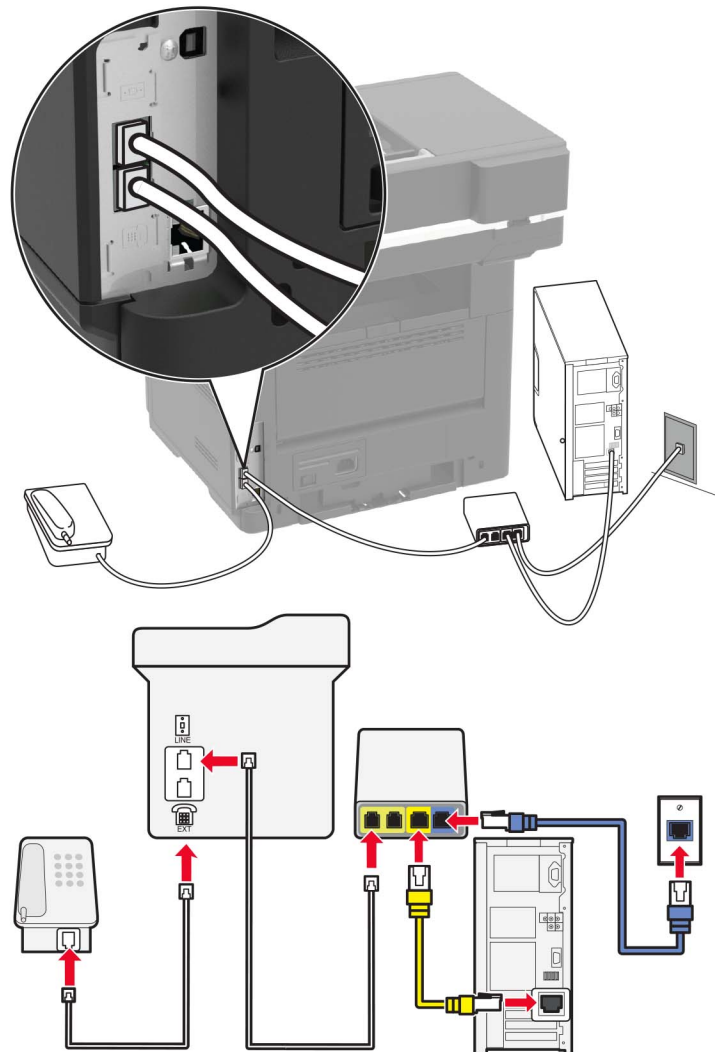

- 1 Connect one end of the telephone cable to the line port of the printer.
- 2 Connect the other end of the cable to the port labeled **Phone Line 1** or **Phone Port** on the VoIP adapter.



**Note:** The port labeled **Phone Line 2** or **Fax Port** is not always active. VoIP providers may charge extra cost for the activation of the second telephone port.

- 3 Connect the telephone to the telephone port of the printer.

**Notes:**

- To check if the telephone port on the VoIP adapter is active, plug an analog telephone into the port, and then listen for a dial tone.
- If you need two telephone ports for your devices, but do not want to pay extra cost, then use a phone splitter. Plug the phone splitter into the port labeled **Phone Line 1** or **Phone Port**, and then plug the printer and telephone into the splitter.
- To check the splitter, plug an analog telephone into the splitter, and then listen for a dial tone.

## Setting up fax using cable modem connection

-  **CAUTION—SHOCK HAZARD:** To avoid the risk of electrical shock, do not set up this product or make any electrical or cabling connections, such as the power cord, fax feature, or telephone, during a lightning storm.
-  **CAUTION—SHOCK HAZARD:** To avoid the risk of electrical shock, do not use the fax feature during a lightning storm.
-  **CAUTION—POTENTIAL INJURY:** To reduce the risk of fire, use only a 26 AWG or larger telecommunications (RJ-11) cord when connecting this product to the public switched telephone network. For users in Australia, the cord must be approved by the Australian Communications and Media Authority.

### Setup 1: Printer is connected directly to a cable modem

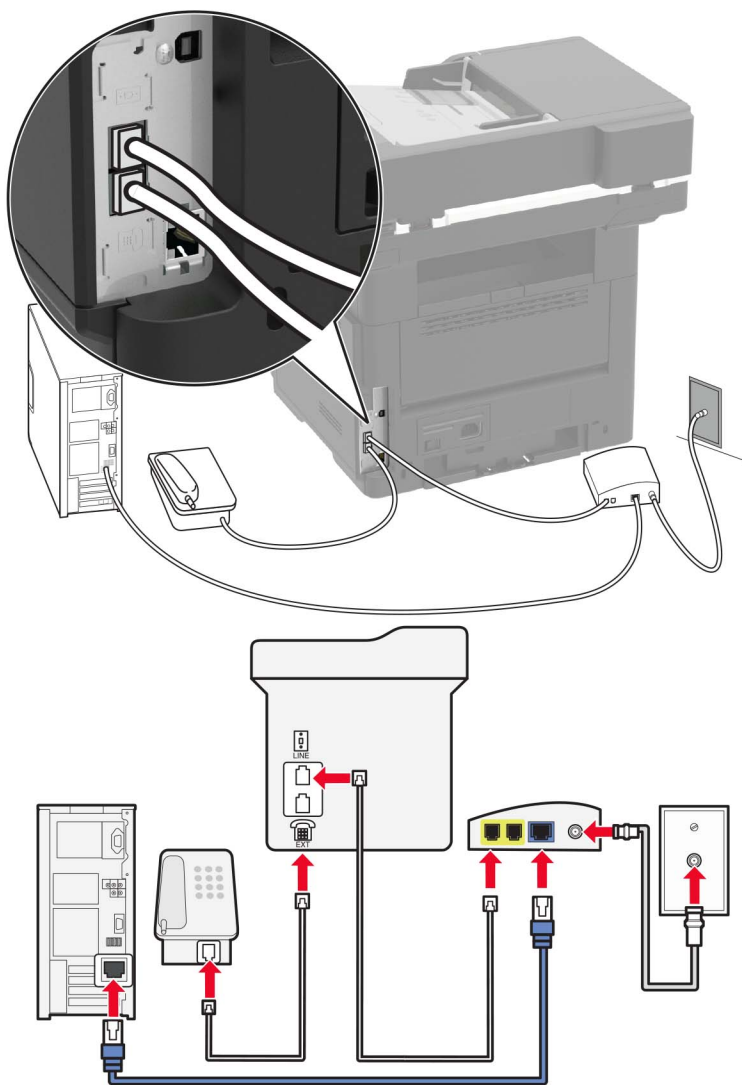

- 1 Connect one end of the telephone cable to the line port of the printer.
- 2 Connect the other end of the cable to the port labeled **Phone Line 1** or **Phone Port** on the cable modem.
- 3 Connect your analog telephone to the telephone port of the printer.

**Note:** To check if the telephone port on the cable modem is active, connect an analog telephone, and then listen for a dial tone.

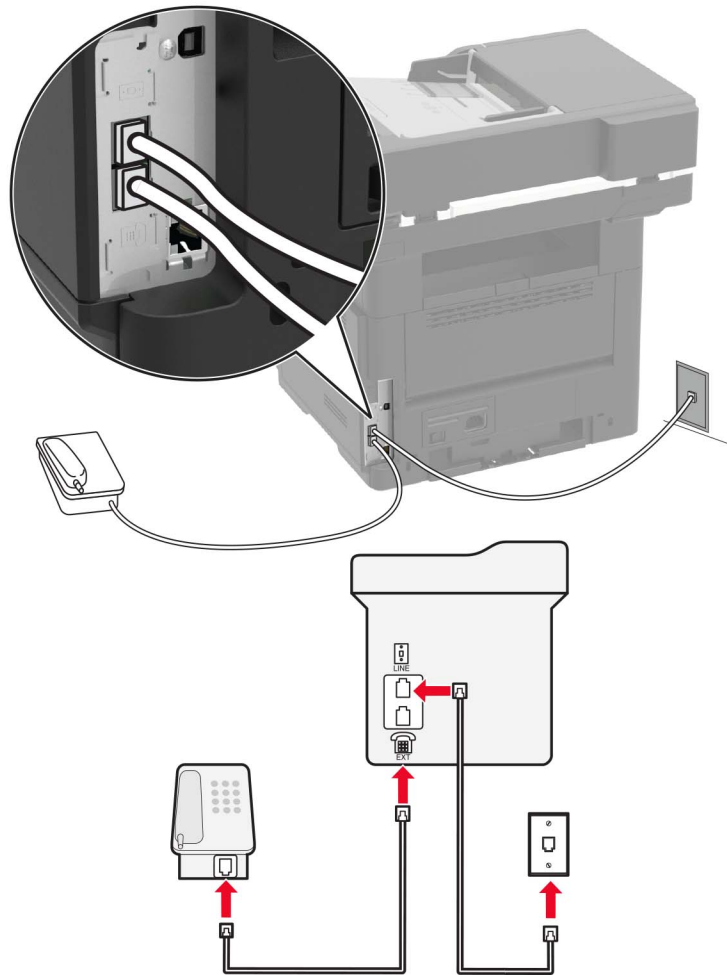

### Setup 2: Printer is connected to a wall jack; cable modem is installed elsewhere in the facility



- 1 Connect one end of the telephone cable to the line port of the printer.
- 2 Connect the other end of the cable to an active analog telephone wall jack.
- 3 Connect your analog telephone to the telephone port of the printer.



## Setting up fax in countries or regions with different telephone wall jacks and plugs

-  **CAUTION—SHOCK HAZARD:** To avoid the risk of electrical shock, do not set up this product or make any electrical or cabling connections, such as the power cord, fax feature, or telephone, during a lightning storm.
-  **CAUTION—SHOCK HAZARD:** To avoid the risk of electrical shock, do not use the fax feature during a lightning storm.
-  **CAUTION—POTENTIAL INJURY:** To reduce the risk of fire, use only a 26 AWG or larger telecommunications (RJ-11) cord when connecting this product to the public switched telephone network. For users in Australia, the cord must be approved by the Australian Communications and Media Authority.

The standard wall jack adopted by most countries or regions is RJ11. If the wall jack or equipment in your facility is not compatible with this type of connection, then use a telephone adapter. An adapter for your country or region may not come with your printer, and you may need to purchase it separately.

There may be an adapter plug installed in the telephone port of the printer. Do not remove the adapter plug from the telephone port of the printer if you are connecting to a serial or cascaded telephone system.

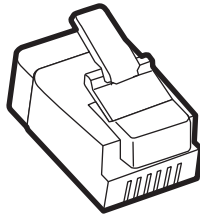

## Connecting the printer to a non-RJ11 wall jack

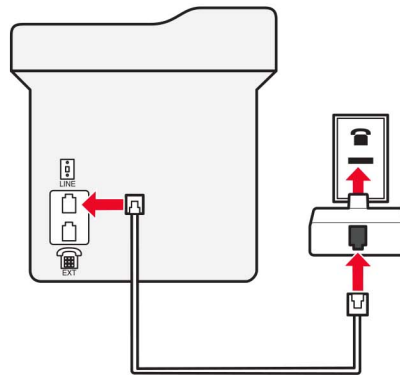
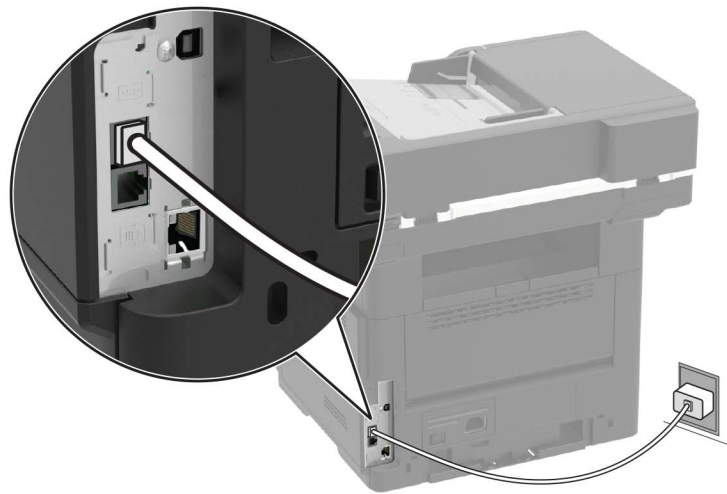

- 1** Connect one end of the telephone cable to the line port of the printer.
- 2** Connect the other end of the cable to the RJ11 adapter, and then connect the adapter to the wall jack.
- 3** If you want to connect another device with a non-RJ11 connector to the same wall jack, then connect it directly to the telephone adapter.

## Connecting the printer to a wall jack in Germany

The German wall jack has two kinds of ports. The N ports are for fax machines, modems, and answering machines. The F port is for telephones. Connect the printer to any of the N ports.

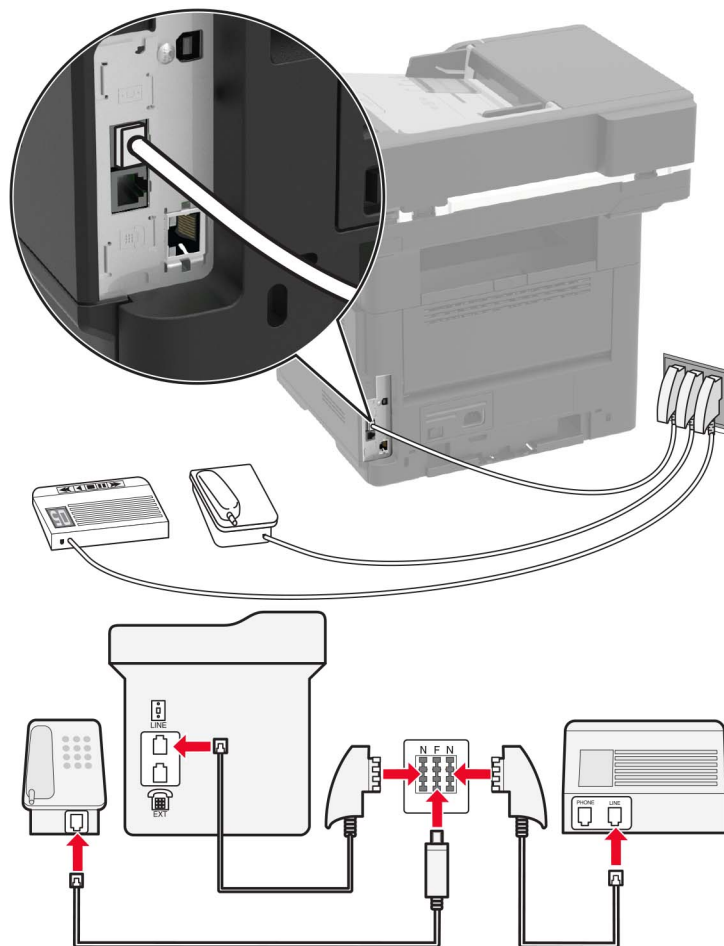

- 1 Connect one end of the telephone cable to the line port of the printer.
- 2 Connect the other end of the cable to the RJ11 adapter, and then connect the adapter to an N port.
- 3 If you want to connect a telephone and answering machine to the same wall jack, then connect the devices as shown.

## Connecting to a distinctive ring service

A distinctive ring service lets you have multiple telephone numbers on one telephone line. Each telephone number is assigned a different ring pattern.

- 1 From the home screen, touch **Settings > Fax > Analog Fax Setup > Fax Receive Settings > Admin Controls > Answer On**.
- 2 Select the ring pattern.
- 3 Apply the changes.

## Setting the fax date and time

- 1 From the home screen, touch **Settings** > **Device** > **Preferences** > **Date and Time** > **Configure**.
- 2 Configure the settings.

## Configuring daylight saving time

- 1 From the home screen, touch **Settings** > **Device** > **Preferences** > **Date and Time** > **Configure**.
- 2 In the Time Zone menu, select **Custom**.
- 3 Configure the settings.

## Sending a fax

### Using the control panel

- 1 Load the original document into the ADF tray or on the scanner glass.
- 2 From the home screen, touch **Fax**, and then enter the needed information.
- 3 If necessary, configure other fax settings.
- 4 Send the fax job.

### Using the computer

#### For Windows users

- 1 With a document open, click **File** > **Print**.
- 2 Select the printer, and then click **Properties**, **Preferences**, **Options**, or **Setup**.
- 3 Click **Fax** > **Enable fax**, and then enter the recipient number.
- 4 If necessary, configure other fax settings.
- 5 Send the fax job.

#### For Macintosh users

- 1 With a document open, choose **File** > **Print**.
- 2 Select the printer and enter the recipient number.
- 3 If necessary, configure other fax settings.
- 4 Send the fax job.

## Scheduling a fax

- 1 Load the original document into the ADF tray or on the scanner glass.
- 2 From the home screen, navigate to:  
**Fax** > enter the fax number > **Send Time**
- 3 Configure the date and time to send the fax.
- 4 If necessary, configure other fax settings.
- 5 Send the fax job.

## Creating a fax destination shortcut

- 1 From the home screen, touch **Fax** > **To**.
- 2 Enter the recipient number.

**Note:** To create a group of fax numbers, touch , and then enter another fax number.

- 3 Touch .
- 4 Enter a shortcut name.
- 5 Apply the changes.

## Changing the fax resolution

- 1 Load an original document into the ADF tray or on the scanner glass.
- 2 From the home screen, touch **Fax**, and then enter the needed information.
- 3 Adjust the Resolution setting.
- 4 Send the fax job.

## Adjusting the fax darkness

- 1 Load an original document into the ADF tray or on the scanner glass.
- 2 From the home screen, touch **Fax**, and then enter the needed information.
- 3 Adjust the Darkness setting.
- 4 Send the fax job.

## Viewing a fax log

- 1 Open a Web browser, and then type the printer IP address in the address field.

**Notes:**

- View the printer IP address on the printer home screen. The IP address appears as four sets of numbers separated by periods, such as 123.123.123.123.
- If you are using a proxy server, then temporarily disable it to load the Web page correctly.

**2** Click **Settings > Reports > Fax**.

**3** Click **Fax Job Log** or **Fax Call Log**.

## Blocking junk faxes

**1** From the home screen, touch **Settings > Fax > Analog Fax Setup > Fax Receive Settings > Admin Controls > Block No Name Fax**.

**2** Apply the changes.

## Holding faxes

**1** From the home screen, touch **Settings > Fax > Analog Fax Setup > Fax Receive Settings > Holding Faxes**.

**2** Select a mode.

## Forwarding a fax

**1** From the home screen, touch **Settings > Fax > Analog Fax Setup > Fax Receive Settings > Admin Controls**.

**2** Configure the Fax Forwarding, Forward To, and Forward to Shortcut settings.

**3** Apply the changes.

# Scanning

## Scanning to an FTP server

- 1 Load the original document into the ADF tray or on the scanner glass.
- 2 From the home screen, touch **FTP**, and then enter the needed information.
- 3 If necessary, configure other FTP settings.
- 4 Send the FTP job.

## Creating an FTP shortcut

- 1 From the home screen, touch **FTP**.
- 2 Enter the FTP server address, and then touch .
- 3 Enter a shortcut name.
- 4 Apply the changes.

## Scanning to a flash drive

- 1 Load an original document into the ADF tray or on the scanner glass.
- 2 Insert the flash drive.



- 3 Touch **Scan to USB** and adjust the settings if necessary.

**Note:** If the USB Drive screen does not appear, then touch **USB Drive** on the home screen.

#### 4 Scan the document.

**Warning—Potential Damage:** To avoid loss of data or printer malfunction, do not touch the flash drive or the printer in the area shown while actively printing, reading, or writing from the memory device.



## Sending scanned documents to a computer

- 1 Load an original document into the ADF tray or on the scanner glass.
- 2 From the home screen, touch **Scan Profiles > Scan To Computer**.
- 3 Select the scan profile where you want to save the document.



# Understanding the printer menus

**Note:** Some of the configuration menus are not displayed according to product firmware version.

## Menu map

Device	<ul style="list-style-type: none"> <li>• <a href="#">Preferences</a></li> <li>• <a href="#">Remote Operator Panel</a></li> <li>• <a href="#">Notifications</a></li> <li>• <a href="#">Power Management</a></li> <li>• <a href="#">Accessibility</a></li> </ul>	<ul style="list-style-type: none"> <li>• <a href="#">Restore Factory Defaults</a></li> <li>• <a href="#">Maintenance</a></li> <li>• <a href="#">Visible Home Screen Icons</a></li> <li>• <a href="#">About This Printer</a></li> </ul>
Print	<ul style="list-style-type: none"> <li>• <a href="#">Layout</a></li> <li>• <a href="#">Setup</a></li> <li>• <a href="#">Quality</a></li> <li>• <a href="#">Job Accounting</a></li> <li>• <a href="#">XPS</a></li> </ul>	<ul style="list-style-type: none"> <li>• <a href="#">PDF</a></li> <li>• <a href="#">PostScript</a></li> <li>• <a href="#">PCL</a></li> <li>• <a href="#">HTML</a></li> <li>• <a href="#">Image</a></li> </ul>
Paper	<ul style="list-style-type: none"> <li>• <a href="#">Tray Configuration</a></li> </ul>	<ul style="list-style-type: none"> <li>• <a href="#">Media Configuration</a></li> </ul>
Copy	<a href="#">Copy Defaults</a>	
Fax	<ul style="list-style-type: none"> <li>• <a href="#">Fax Mode</a></li> <li>• <a href="#">Analog Fax Setup</a></li> </ul>	<ul style="list-style-type: none"> <li>• <a href="#">Fax Server Setup</a></li> </ul>
E-mail	<ul style="list-style-type: none"> <li>• <a href="#">E-mail Setup</a></li> <li>• <a href="#">E-mail Defaults</a></li> </ul>	<ul style="list-style-type: none"> <li>• <a href="#">Web Link Setup</a></li> </ul>
FTP	<a href="#">FTP Defaults</a>	
Network/Ports	<ul style="list-style-type: none"> <li>• <a href="#">Network Overview</a></li> <li>• <a href="#">Wireless</a></li> <li>• <a href="#">Ethernet</a></li> <li>• <a href="#">TCP/IP</a></li> <li>• <a href="#">SNMP</a></li> <li>• <a href="#">IPSec</a></li> <li>• <a href="#">802.1x</a></li> </ul>	<ul style="list-style-type: none"> <li>• <a href="#">LPD Configuration</a></li> <li>• <a href="#">HTTP/FTP Settings</a></li> <li>• <a href="#">ThinPrint</a></li> <li>• <a href="#">USB</a></li> <li>• <a href="#">Google Cloud Print</a></li> <li>• <a href="#">Wi-Fi Direct</a></li> </ul>
Security	<ul style="list-style-type: none"> <li>• <a href="#">Login Methods</a></li> <li>• <a href="#">Schedule USB Devices</a></li> <li>• <a href="#">Security Audit Log</a></li> <li>• <a href="#">Login Restrictions</a></li> <li>• <a href="#">Confidential Print Setup</a></li> </ul>	<ul style="list-style-type: none"> <li>• <a href="#">Disk Encryption</a></li> <li>• <a href="#">Erase Temporary Data Files</a></li> <li>• <a href="#">Solutions LDAP Settings</a></li> <li>• <a href="#">Mobile Services Management</a></li> <li>• <a href="#">Miscellaneous</a></li> </ul>
Reports	<ul style="list-style-type: none"> <li>• <a href="#">Menu Settings Page</a></li> <li>• <a href="#">Device</a></li> <li>• <a href="#">Print</a></li> </ul>	<ul style="list-style-type: none"> <li>• <a href="#">Shortcuts</a></li> <li>• <a href="#">Fax</a></li> <li>• <a href="#">Network</a></li> </ul>

<a href="#">Help</a>	<ul style="list-style-type: none"> <li>• Print All Guides</li> <li>• Connection Guide</li> <li>• Copy Guide</li> <li>• E-mail Guide</li> <li>• Fax Guide</li> <li>• FTP Guide</li> </ul>	<ul style="list-style-type: none"> <li>• Information Guide</li> <li>• Media Guide</li> <li>• Mono Quality Guide</li> <li>• Moving Guide</li> <li>• Print Quality Guide</li> <li>• Supplies Guide</li> </ul>
<a href="#">Troubleshooting</a>	<ul style="list-style-type: none"> <li>• Print Quality Test Pages</li> </ul>	<ul style="list-style-type: none"> <li>• Cleaning the scanner</li> </ul>

## Device

### Preferences

Menu item	Description
<b>Display Language</b> [List of languages]	Set the language of the text that appears on the display.
<b>Country/Region</b> [List of countries or regions]	Identify the country or region where the printer is configured to operate.
<b>Run initial setup</b> On Off*	Run the setup wizard.
<b>Keyboard</b> Keyboard Type [List of languages]	Select a language as a keyboard type.  <b>Notes:</b> <ul style="list-style-type: none"> <li>• All the Keyboard Type values may not appear or may require special hardware to appear.</li> <li>• This menu item appears only in some printer models.</li> </ul>
<b>Displayed information</b> Display Text 1 [IP Address*] Display Text 2 [Date/Time*] Custom Text 1 Custom Text 2	Specify the information to appear on the home screen.  <b>Note:</b> Custom Text 1 and Custom Text 2 appear only in some printer models.
<b>Date and Time</b> Configure Current Date and Time Manually Set Date and Time Date Format [MM-DD-YYYY*] Time Format [12 hour A.M./P.M.*] Time Zone [GMT*]	Configure the printer date and time.
<b>Note:</b> An asterisk (*) next to a value indicates the factory default setting.	

Menu item	Description
<b>Date and Time</b> Network Time Protocol Enable NTP [On*] NTP Server Enable Authentication	Configure the settings for Network Time Protocol (NTP). <b>Notes:</b> <ul style="list-style-type: none"> <li>• Enable Authentication appears only in some printer models.</li> <li>• When Enable Authentication is set to MD5 key, Key ID and Password appear.</li> </ul>
<b>Paper Sizes</b> U.S.* Metric	Specify the unit of measurement for paper sizes. <b>Note:</b> The country or region selected in the initial setup wizard determines the initial paper size setting.
<b>Screen Brightness</b> 20–100% (100*)	Adjust the brightness of the display. <b>Note:</b> This menu item appears only in some printer models.
<b>Flash Drive Access</b> Enabled* Disabled	Enable access to the flash drive.
<b>Allow Background Removal</b> On* Off	Specify whether background removal is allowed.
<b>Allow Custom Job scans</b> On* Off	Scan multiple jobs to one file.
<b>One Page Flatbed Scanning</b> On Off*	Set copies from the scanner glass to only one page at a time.
<b>Audio Feedback</b> Button Feedback On* Off	Enable audio feedback for button presses, panel interactions, paper loaded prompts, and error notifications. <b>Note:</b> This menu item appears only in some printer models.
<b>Audio Feedback</b> Volume 1–10 (5*)	Adjust the volume of the printer speakers. <b>Notes:</b> <ul style="list-style-type: none"> <li>• Changes to the volume are applied after the current user session ends.</li> <li>• This menu item appears only in some printer models.</li> </ul>
<b>Screen Timeout</b> 10–300 (60*)	Set the idle time in seconds before the display shows the home screen, or before the printer logs off a user account automatically.
<b>Note:</b> An asterisk (*) next to a value indicates the factory default setting.	

## Remote Operator Panel

Menu item	Description
<b>External VNC Connection</b> Don't Allow* Allow	Connect an external Virtual Network Computing (VNC) client to the remote control panel.
<b>Authentication Type</b> None* Standard Authentication	Set the authentication type when accessing the VNC client server.
<b>VNC Password</b>	Specify the password to connect to the VNC client server. <b>Note:</b> This menu item appears only if Authentication Type is set to Standard Authentication.
<b>Note:</b> An asterisk (*) next to a value indicates the factory default setting.	

## Notifications

Menu item	Description
<b>Error Lighting</b> Off On*	Set the indicator light to come on when a printer error occurs. <b>Note:</b> This menu item appears only in some printer models.
<b>ADF Loaded Beep</b> Off On*	Enable a sound when loading paper into the ADF.
<b>Alarm Control</b> Off Single* Continuous	Set the number of times that the alarm sounds when the printer requires user intervention.
<b>Supplies</b> Show Supply Estimates Show estimates* Do not show estimates	Show the estimated status of the supplies.
<b>Supplies</b> Cartridge Alarm Off* Single Continuous	Set the number of times that the alarm sounds when the toner cartridge is low.
<b>E-mail Alerts Setup</b>	Configure the printer to send e-mail alerts to a list of contacts when the printer requires user intervention.
<b>Error Prevention</b> Jam Assist Off On*	Set the printer to flush automatically blank pages or pages with partial prints after a jammed page is cleared.
<b>Note:</b> An asterisk (*) next to a value indicates the factory default setting.	

Menu item	Description
<p><b>Error Prevention</b>                      Auto Continue                      Disabled                      5–255 (5*)</p>	<p>Let the printer to continue processing or printing a job automatically after clearing certain attendance conditions.</p>
<p><b>Error Prevention</b>                      Auto Reboot                      Auto Reboot                      Reboot when idle                      Reboot always*                      Reboot never</p>	<p>Set the printer to restart when an error occurs.</p>
<p><b>Error Prevention</b>                      Auto Reboot                      Max Auto Reboots                      1–20 (2*)</p>	<p>Set the number of automatic reboots that the printer can perform.</p>
<p><b>Error Prevention</b>                      Auto Reboot                      Auto Reboot Window                      1–525600 (720*)</p>	<p>Set the number of seconds before the printer performs an automatic reboot.</p>
<p><b>Error Prevention</b>                      Auto Reboot                      Auto Reboot Counter</p>	<p>Show a read-only information of the reboot counter.</p>
<p><b>Error Prevention</b>                      Auto Reboot                      Reset Auto Reboot Counter                      Cancel                      Continue</p>	<p>Reset Auto Reboot Counter.</p>
<p><b>Error Prevention</b>                      Display Short Paper Error                      On                      Auto-clear*</p>	<p>Set the printer to show a message when a short paper error occurs.  <b>Note:</b> Short paper refers to the size of the paper loaded.</p>
<p><b>Error Prevention</b>                      Page Protect                      Off*                      On</p>	<p>Set the printer to process the entire page into the memory before printing it.</p>
<p><b>Jam Content Recovery</b>                      Jam Recovery                      Off                      On                      Auto*</p>	<p>Set the printer to reprint jammed pages.</p>
<p><b>Note:</b> An asterisk (*) next to a value indicates the factory default setting.</p>	

Menu item	Description
<b>Jam Content Recovery</b> Scanner Jam Recovery Job level Page level*	Specify how to restart a scan job after resolving a paper jam.
<b>Note:</b> An asterisk (*) next to a value indicates the factory default setting.	

## Power Management

Menu item	Description
<b>Sleep Mode Profile</b> Print With Display Off Display on when printing Allow printing with display off*	Allow printing with the display turned off.
<b>Timeouts</b> Sleep Mode 1–120 minutes (15*)	Set the idle time before the printer begins operating in Sleep mode.
<b>Timeouts</b> Hibernate Timeout Disabled 1 hour 2 hours 3 hours 6 hours 1 day 2 days 3 days* 1 week 2 weeks 1 month	Set the time before the printer enters Hibernate mode.
<b>Timeouts</b> Hibernate Timeout on Connection Hibernate Do Not Hibernate*	Set the printer to Hibernate mode even when an active Ethernet connection exists.
<b>Eco-Mode</b> Off* Energy Energy/Paper Paper	Minimize the use of energy, paper, or specialty media.  <b>Note:</b> Setting Eco-Mode to Energy or Paper may affect printer performance, but not print quality.
<b>Schedule Power Modes</b> Schedules	Schedule the printer when to enter Sleep or Hibernate mode.  <b>Note:</b> This menu item appears only in some printer models.
<b>Note:</b> An asterisk (*) next to a value indicates the factory default setting.	

## Accessibility

Menu item	Description
<b>Duplicate Key Strike Interval</b> 0–5 (0*)	Set the interval in seconds during which the printer ignores duplicate key presses on an attached keyboard.
<b>Key Repeat Initial Delay</b> 0.25–5 (1*)	Set the initial length of delay in seconds before a repeating key starts repeating. <b>Note:</b> This menu item appears only when a keyboard is attached to the printer.
<b>Key Repeat Rate</b> 0.5–30 (30*)	Set the number of presses per second for a repeating key. <b>Note:</b> This menu item appears only when a keyboard is attached to the printer.
<b>Note:</b> An asterisk (*) next to a value indicates the factory default setting.	

## Restore Factory Defaults

Menu item	Description
<b>Restore Settings</b> Restore all settings Restore printer settings Restore network settings Restore fax settings Restore app settings	Restore the printer factory default settings. <b>Note:</b> The default value is the value selected during the initial setup.

## Maintenance

### Configuration Menu

Menu item	Description
<b>USB Configuration</b> USB PnP 1* 2	Change the USB driver mode of the printer to improve its compatibility with a personal computer.
<b>USB Configuration</b> USB Scan to Local On* Off	Set whether the USB device driver enumerates as a USB Simple device (single interface) or as a USB Composite device (multiple interfaces).
<b>USB Configuration</b> USB Speed Full Auto*	Set the USB port to run at full speed and disable its high-speed capabilities.
<b>Tray Configuration</b> Tray Linking Automatic* Off	Set the printer to link the trays that have the same paper type and paper size settings.
<b>Note:</b> An asterisk (*) next to a value indicates the factory default setting.	

Menu item	Description
<p><b>Tray Configuration</b></p> <ul style="list-style-type: none"> <li>Show Tray Insert Message                             <ul style="list-style-type: none"> <li>Off</li> <li>Only for unknown sizes*</li> <li>Always</li> </ul> </li> </ul>	<p>Show the <b>Tray Insert</b> message.</p>
<p><b>Tray Configuration</b></p> <ul style="list-style-type: none"> <li>A5 Loading                             <ul style="list-style-type: none"> <li>Short Edge*</li> <li>Long Edge</li> </ul> </li> </ul>	<p>Specify the page orientation when loading A5-size paper.</p>
<p><b>Tray Configuration</b></p> <ul style="list-style-type: none"> <li>Paper Prompts                             <ul style="list-style-type: none"> <li>Auto*</li> <li>Multipurpose Feeder</li> <li>Manual Paper</li> </ul> </li> <li>Envelope Prompts                             <ul style="list-style-type: none"> <li>Auto*</li> <li>Multipurpose Feeder</li> <li>Manual Envelope</li> </ul> </li> </ul>	<p>Set the paper source that the user fills when a prompt to load paper or envelope appears.</p> <p><b>Note:</b> For Multipurpose Feeder to appear, set Configure MP to Cassette from the Paper menu.</p>
<p><b>Tray Configuration</b></p> <ul style="list-style-type: none"> <li>Action for Prompts                             <ul style="list-style-type: none"> <li>Prompt user*</li> <li>Continue</li> <li>Use current</li> </ul> </li> </ul>	<p>Set the printer to resolve paper- or envelope-related change prompts.</p>
<p><b>Reports</b></p> <ul style="list-style-type: none"> <li>Menu Settings Page</li> <li>Event Log</li> <li>Event Log Summary</li> </ul>	<p>Print reports about printer menu settings, status, and event logs.</p>
<p><b>Supply Usage And Counters</b></p> <ul style="list-style-type: none"> <li>Clear Supply Usage History</li> <li>Reset Black Cartridge Counter</li> <li>Reset Black Imaging Unit Counter</li> <li>Reset Maintenance Counter</li> </ul>	<p>Reset the supply page counter or view the total printed pages.</p>
<p><b>Printer Emulations</b></p> <ul style="list-style-type: none"> <li>PPDS Emulation                             <ul style="list-style-type: none"> <li>Off*</li> <li>On</li> </ul> </li> </ul>	<p>Set the printer to recognize and use the PPDS data stream.</p>
<p><b>Fax Configuration</b></p> <ul style="list-style-type: none"> <li>Fax Low Power Support                             <ul style="list-style-type: none"> <li>Disable Sleep</li> <li>Permit Sleep</li> <li>Auto*</li> </ul> </li> </ul>	<p>Set the fax chip to enter low-power mode whenever the printer determines that it should.</p>
<p><b>Note:</b> An asterisk (*) next to a value indicates the factory default setting.</p>	



Menu item	Description
<b>Print Configuration</b> Font Sharpening 0–150(24*)	Set a text point-size value below which the high-frequency screens are used when printing font data.  For example, if the value is 24, then all fonts sized 24 points or less use the high-frequency screens.
<b>Print Configuration</b> Print Density 1–5 (3*) Copy Density 1–5 (3*)	Adjust the toner density when printing or copying documents.
<b>Device Operations</b> Quiet Mode Off* On	Set the printer to operate in Quiet Mode.
<b>Device Operations</b> Panel Menus Enable* Disable	Enable access to the control panel menus.
<b>Device Operations</b> Safe Mode Off* On	Set the printer to operate in a special mode, in which it attempts to continue offering as much functionality as possible, despite known issues.  For example, when set to On and the duplex motor is nonfunctional, the printer performs one-sided printing for a two-sided print job.
<b>Device Operations</b> Minimum Copy Memory 20MB* 30MB 50MB 80MB 100MB	Set the memory allocation for storing copy jobs.  <b>Note:</b> The values appear only if the amount of installed DRAM is at least twice the amount of the value.
<b>Device Operations</b> Clear Custom Status	Erase user-defined strings for the Default or Alternate custom messages.
<b>Device Operations</b> Clear all remotely-installed messages	Erase messages that were remotely installed.
<b>Device Operations</b> Automatically Display Error Screens On* Off	Show existing error messages on the display after the printer remains inactive on the home screen for a length of time equal to the Screen Timeout setting.
<b>Device Operations</b> Honor orientation on fast path copy Off* On	Enable the printer to use the Orientation setting under the Copy menu when sending quick copy jobs.
<b>Note:</b> An asterisk (*) next to a value indicates the factory default setting.	

Menu item	Description
<b>Scanner Configuration</b> Scanner Manual Registration Front ADF Registration Rear ADF Registration Flatbed Registration	Manually register the flatbed and ADF after replacing the ADF, scanner glass, or controller board.
<b>Scanner Configuration</b> Edge Erase ADF Edge Erase 0–6 (3*) Flatbed Edge Erase 0–6 (3*)	Set the size, in millimeters, of the no-print area around an ADF or flatbed scan job.
<b>Scanner Configuration</b> Disable Scanner Enabled* Disabled ADF Disabled	Disable the scanner if it is not working properly.
<b>Scanner Configuration</b> Scanner Manual Registration Print Quick Test	Print a test page that shows the scanner margin settings.
<b>Scanner Configuration</b> Tiff Byte Order CPU Endianness* Little Endian Big Endian	Determine the byte order of a TIFF-formatted scan output.
<b>Scanner Configuration</b> Exact Tiff Rows Per Strip On* Off	Set the RowsPerStrip tag value of a TIFF-formatted scan output.

**Note:** An asterisk (\*) next to a value indicates the factory default setting.

### Out of Service Erase

Menu item	Description
<b>Out of Service Erase</b> Memory Last Sanitized Hard Disk Last Sanitized	Show information on when the printer memory or hard disk was last sanitized.  <b>Note:</b> Hard Disk Last Sanitized appears only in printers with a hard disk installed.
<b>Out of Service Erase</b> Sanitize all information on nonvolatile memory Sanitize all information on hard disk Erase all printer and network settings	Clear all settings and applications that are stored in the printer memory or hard disk.  <b>Note:</b> Sanitize all information on hard disk appears only in printers with a hard disk installed.

## Visible Home Screen Icons

Menu	Description
Copy E-mail Fax Status/Supplies Job Queue Change Language Shortcut Center Address Book Bookmarks Held Jobs USB FTP	Specify which icons to show on the home screen.

## About this Printer

Menu item	Description
<b>Asset Tag</b>	Show the serial number of the printer.
<b>Printer's Location</b>	Identify the printer location. Maximum length is 63 characters.
<b>Contact</b>	Personalize the printer name. Maximum length is 63 characters.
<b>Export Configuration File to USB</b>	Export configuration files to a flash drive.
<b>Export Compressed Logs to USB</b>	Export compressed log files to a flash drive.

## Print

### Layout

Menu item	Description
<b>Sides</b> 1-sided* 2-sided	Specify whether to print on one side or two sides of the paper.
<b>Flip Style</b> Long Edge* Short Edge	Determine which side of the paper (long edge or short edge) is bound when performing two-sided printing.  <b>Note:</b> Depending on the option selected, the printer automatically offsets each printed information of the page to bind the job correctly.
<b>Blank Pages</b> Print Do Not Print*	Print blank pages that are included in a print job.
<b>Note:</b> An asterisk (*) next to a value indicates the factory default setting.	

Menu item	Description
<b>Collate</b> Off [1,1,1,2,2,2]* On [1,2,1,2,1,2]	Keep the pages of a print job stacked in sequence, particularly when printing multiple copies of the job.
<b>Separator Sheets</b> None* Between Copies Between Jobs Between Pages	Insert blank separator sheets when printing.
<b>Separator Sheet Source</b> Tray [x] (1*) Multipurpose Feeder	Specify the paper source for the separator sheet. <b>Note:</b> The multipurpose feeder is available only in some printer models.
<b>Pages per Side</b> Off* 2 pages per side 3 pages per side 4 pages per side 6 pages per side 9 pages per side 12 pages per side 16 pages per side	Print multiple page images on one side of a sheet of paper.
<b>Pages per Side Ordering</b> Horizontal* Reverse Horizontal Vertical Reverse Vertical	Specify the positioning of multiple page images when using Pages per Side. <b>Note:</b> The positioning depends on the number of page images and their page orientation.
<b>Pages per Side Orientation</b> Auto* Landscape Portrait	Specify the orientation of a multiple-page document when using Pages per Side.
<b>Pages per Side Border</b> None* Solid	Print a border around each page image when using Pages per Side.
<b>Copies</b> 1–9999 (1*)	Specify the number of copies for each print job.
<b>Print Area</b> Normal* Fit to page Whole Page	Set the printable area on a sheet of paper.
<b>Note:</b> An asterisk (*) next to a value indicates the factory default setting.	

## Setup

Menu item	Description
<b>Printer Language</b> PCL Emulation PS Emulation*	Set the printer language. <b>Note:</b> Setting a printer language default does not prevent a software program from sending print jobs that use another printer language.
<b>Job Waiting</b> Off* On	Preserve print jobs requiring supplies so that jobs not requiring the missing supplies can print. <b>Note:</b> This menu item appears only when a printer hard disk is installed.
<b>Job Hold Timeout</b> 0–255 (30*)	Set the time in seconds that the printer waits for user intervention before it holds jobs that require unavailable resources and continues to print other jobs in the print queue. <b>Note:</b> This menu item appears only when a printer hard disk is installed.
<b>Download Target</b> RAM* Disk	Specify where to save all permanent resources, such as fonts and macros, that have been downloaded to the printer. <b>Note:</b> This menu item appears only when a printer hard disk is installed.
<b>Resource Save</b> Off* On	Determine what the printer does with downloaded resources, such as fonts and macros, when it receives a job that requires more than the available memory. <b>Notes:</b> <ul style="list-style-type: none"> <li>• When set to Off, the printer retains downloaded resources only until memory is needed. Resources associated with the inactive printer language are deleted.</li> <li>• When set to On, the printer preserves all the permanent downloaded resources across all language switches. When necessary, the printer shows memory full messages instead of deleting permanent resources.</li> </ul>
<b>Print All Order</b> Alphabetical* Newest First Oldest First	Specify the order in which held and confidential jobs are printed when Print All is selected. <b>Note:</b> This menu item appears only when a printer hard disk is installed.
<b>Note:</b> An asterisk (*) next to a value indicates the factory default setting.	

## Quality

Menu item	Description
<b>Print Resolution</b> 600 dpi* 1200 Image Q 2400 Image Q 1200 dpi 300 dpi	Set the resolution for the text and images on the printed output. <b>Note:</b> Resolution is determined in dots per inch or image quality.
<b>Note:</b> An asterisk (*) next to a value indicates the factory default setting.	

Menu item	Description
<b>Pixel Boost</b> Off* Fonts Horizontally Vertically Both directions	Enable more pixels to print in clusters for clarity, in order to enhance text and images.
<b>Toner Darkness</b> 1–10 (8*)	Determine the lightness or darkness of text images.
<b>Halftone</b> Normal* Detail	Enhance the printed output to have smoother lines with sharper edges.
<b>Brightness</b> -6 to 6 (0*)	Adjust the brightness of the printed output.
<b>Contrast</b> 0 to 5 (0*)	Adjust the contrast of the printed output.
<b>Gray Correction</b> Off Auto*	Adjust the contrast enhancement applied to images.
<b>Note:</b> An asterisk (*) next to a value indicates the factory default setting.	

## Job Accounting

Menu item	Description
<b>Job Accounting</b> Off* On	Set the printer to create a log of the print jobs that it receives.
<b>Accounting Log Frequency</b> Daily Weekly Monthly*	Specify how often the printer creates a log file.
<b>Log Action at End of Frequency</b> None* E-mail Current Log E-mail & Delete Current Log Post Current Log Post & Delete Current Log	Specify how the printer responds when the frequency threshold expires. <b>Note:</b> The value defined in Accounting Log Frequency determines when this action is triggered.
<b>Log Near Full Level</b> Off On*	Specify the maximum size of the log file before the printer executes the Log Action at Near Full.
<b>Note:</b> An asterisk (*) next to a value indicates the factory default setting.	

Menu item	Description
<b>Log Action at Near Full</b> None* E-mail Current Log E-mail & Delete Current Log E-mail & Delete Oldest Log Post Current Log Post & Delete Current Log Post & Delete Oldest Log Delete Current Log Delete Oldest Log Delete All Logs Delete All But Current	Specify how the printer responds when the hard disk is nearly full. <b>Note:</b> The value defined in Log Near Full Level determines when this action is triggered.
<b>Log Action at Full</b> None* E-mail & Delete Current Log E-mail & Delete Oldest Log Post & Delete Current Log Post & Delete Oldest Log Delete Current Log Delete Oldest Log Delete All Logs Delete All But Current	Specify how the printer responds when disk usage reaches the maximum limit.
<b>URL to Post Log</b>	Specify where the printer posts job accounting logs.
<b>E-mail Address to Send Logs</b>	Specify the e-mail address to which the printer sends job accounting logs.
<b>Log File Prefix</b>	Specify the prefix for the log file name. <b>Note:</b> The current host name defined in the TCP/IP menu is used as the default log file prefix.
<b>Note:</b> An asterisk (*) next to a value indicates the factory default setting.	

## XPS

Menu item	Description
<b>Print Error Pages</b> Off* On	Print a test page that contains information on errors, including XML markup errors.
<b>Minimum Line Width</b> 1–30 (2*)	Set the minimum stroke width of any job printed in 1200 dpi.
<b>Note:</b> An asterisk (*) next to a value indicates the factory default setting.	

## PDF

Menu item	Description
<b>Scale to Fit</b> Off* On	Scale the page content to fit the selected paper size.
<b>Annotations</b> Do Not Print* Print	Specify whether to print annotations in the PDF.
<b>Note:</b> An asterisk (*) next to a value indicates the factory default setting.	

## PostScript

Menu item	Description
<b>Print PS Error</b> On Off*	Print a test page that contains the PostScript error.
<b>Minimum Line Width</b> 1–30 (2*)	Set the minimum stroke width of any job printed in 1200 dpi.
<b>Lock PS Startup Mode</b> On Off*	Disable the SysStart file.
<b>Font Priority</b> Resident* Flash/Disk	Establish the font search order. <b>Notes:</b> <ul style="list-style-type: none"> <li>Resident sets the printer to search its memory for the requested font before searching the flash memory.</li> <li>Flash/Disk sets the printer to search the flash memory for the requested font before searching the printer memory.</li> <li>This menu item appears only when a flash memory is installed.</li> </ul>
<b>Wait Timeout</b> Disabled 15–65535 (40*)	Set the printer to wait for additional data before canceling a print job.
<b>Note:</b> An asterisk (*) next to a value indicates the factory default setting.	



## PCL

Menu item	Description
<b>Font Source</b> Resident* Disk Download Flash All	Choose the source which contains the default font selection.  <b>Notes:</b> <ul style="list-style-type: none"> <li>Flash and Disk appear only in some printer models.</li> <li>For Flash and Disk to appear, make sure that they are not read- or write-protected.</li> </ul>
<b>Font Name</b> [List of available fonts]	Select a font from the specified font source.
<b>Symbol Set</b> [List of available symbol set]	Specify the symbol set for each font name.  <b>Note:</b> A symbol set is a set of alphabetic and numeric characters, punctuation, and special symbols. Symbol sets support the different languages or specific programs such as math symbols for scientific text.
<b>Pitch</b> 0.08–100 (10*)	Specify the font pitch for scalable monospaced fonts.  <b>Note:</b> Pitch refers to the number of fixed-space characters in a horizontal inch of type.
<b>Orientation</b> Portrait* Landscape	Specify the orientation of text and graphics on the page.
<b>Lines per Page</b> 1–255	Specify the number of lines of text for each page printed through the PCL® datastream.  <b>Notes:</b> <ul style="list-style-type: none"> <li>This menu item activates vertical escapement that causes the selected number of requested lines to print between the default margins of the page.</li> <li>60 is the U.S. factory default setting. 64 is the international factory default setting.</li> </ul>
<b>PCL5 Minimum Line Width</b> 1–30 (2*)	Set the initial minimum stroke width.  <b>Notes:</b>
<b>PCLXL Minimum Line Width</b> 1–30 (2*)	<ul style="list-style-type: none"> <li>Jobs printed in 1200 dpi use the value directly.</li> <li>Jobs printed in 4800CQ use half the value.</li> </ul>
<b>A4 Width</b> 198 mm* 203 mm	Set the width of the logical page on A4-size paper.  <b>Note:</b> Logical page is the space on the physical page where data is printed.
<b>Auto CR after LF</b> Off* On	Set the printer to perform a carriage return after a line feed control command.  <b>Note:</b> Carriage return is a mechanism that commands the printer to move the position of the cursor to the first position on the same line.
<b>Note:</b> An asterisk (*) next to a value indicates the factory default setting.	

Menu item	Description
<b>Auto LF after CR</b> Off* On	Set the printer to perform a line feed after a carriage return control command.
<b>Tray Renumber</b> Assign MP Feeder Off* None 0–201 Assign Tray [x] Off* None 0–201 Assign Manual Paper Off* None 0–201 Assign Manual Envelope Off* None 0–201	Configure the printer to work with print drivers or applications that use different source assignments for the paper source.
<b>Tray Renumber</b> View Factory Defaults Restore Defaults	Show the factory default setting assigned for each paper source.
<b>Tray Renumber</b> Restore Defaults	Return all tray assignments to factory default values.
<b>Print Timeout</b> Disabled 1–255 (90*)	Set the printer to end a print job after it has been idle for the specified amount of time in seconds.
<b>Note:</b> An asterisk (*) next to a value indicates the factory default setting.	

## HTML

Menu item	Description
<b>Font Name</b> [List of fonts] (Times*)	Set the font to use for HTML documents.
<b>Font Size</b> 1–255 (12*)	Set the font size to use for HTML documents.
<b>Scale</b> 1–400% (100*)	Scale HTML documents.
<b>Note:</b> An asterisk (*) next to a value indicates the factory default setting.	

Menu item	Description
<b>Orientation</b> Portrait* Landscape	Set the page orientation for HTML documents.
<b>Margin Size</b> 8–255 mm (19*)	Set the page margin for HTML documents.
<b>Backgrounds</b> Do Not Print Print*	Print background information or graphics for HTML documents.
<b>Note:</b> An asterisk (*) next to a value indicates the factory default setting.	

## Image

Menu item	Description
<b>Auto Fit</b> Off On*	Select the best available paper size and orientation setting for an image. <b>Note:</b> When set to On, this menu item overrides the scaling and orientation settings for the image.
<b>Invert</b> Off* On	Invert bitonal monochrome images. <b>Note:</b> This menu item does not apply to GIF or JPEG image formats.
<b>Scaling</b> Best Fit* Anchor Top Left Anchor Center Fit Height/Width Fit Height Fit Width	Adjust the image to fit the printable area. <b>Note:</b> When Auto Fit is set to On, Scaling is automatically set to Best Fit.
<b>Orientation</b> Portrait* Landscape Reverse Portrait Reverse Landscape	Specify the orientation of text and graphics on the page.
<b>Note:</b> An asterisk (*) next to a value indicates the factory default setting.	

# Paper

## Tray Configuration

Menu item	Description
<p><b>Default Source</b></p> <ul style="list-style-type: none"> <li>Tray [x] (1*)</li> <li>Multipurpose Feeder</li> <li>Manual Paper</li> <li>Manual Envelope</li> </ul>	<p>Set the paper source for all print jobs.</p> <p><b>Note:</b> Multipurpose Feeder appears only when Configure MP is set to Cassette.</p>
<p><b>Paper Size/Type</b></p> <ul style="list-style-type: none"> <li>Tray [x]</li> <li>Multipurpose Feeder</li> <li>Manual Paper</li> <li>Manual Envelope</li> </ul>	<p>Specify the paper size or paper type loaded in each paper source.</p>
<p><b>Configure MP</b></p> <ul style="list-style-type: none"> <li>Cassette*</li> <li>Manual</li> <li>First</li> </ul>	<p>Set the printer when to pick paper from the multipurpose feeder.</p> <p><b>Notes:</b></p> <ul style="list-style-type: none"> <li>• When set to Cassette, the printer treats the multipurpose feeder like a tray.</li> <li>• When set to Manual, the printer treats the multipurpose feeder like a manual feeder.</li> <li>• When set to First, the printer picks paper from the multipurpose feeder until it is empty, regardless of the required paper source or paper size.</li> </ul>
<p><b>Substitute Size</b></p> <ul style="list-style-type: none"> <li>Off</li> <li>Statement/A5</li> <li>Letter/A4</li> <li>All Listed*</li> </ul>	<p>Set the printer to substitute a specified paper size if the requested size is not loaded in any paper source.</p> <p><b>Notes:</b></p> <ul style="list-style-type: none"> <li>• Off prompts the user to load the required paper size.</li> <li>• Statement/A5 prints A5-size document on statement when loading statement and statement-size jobs on A5 paper size when loading A5.</li> <li>• Letter/A4 prints A4-size document on letter when loading letter and letter-size jobs on A4 paper size when loading letter.</li> <li>• All Listed substitutes Letter/A4.</li> </ul>

**Note:** An asterisk (\*) next to a value indicates the factory default setting.

## Media Configuration

### Universal Setup

Menu item	Description
<b>Units of Measure</b> Inches Millimeters	Specify the unit of measurement for the universal paper. <b>Note:</b> Inches is the U.S. factory default setting. Millimeters is the international factory default setting.
<b>Portrait Width</b> 3–52 inches (8.50*) 76–1321 mm (216*)	Set the portrait width of the universal paper.
<b>Portrait Height</b> 3–52 inches (14*) 76–1321 mm (356*)	Set the portrait height of the universal paper.
<b>Feed Direction</b> Short Edge* Long Edge	Set the printer to pick paper from the short edge or long edge direction. <b>Note:</b> Long Edge appears only when the longest edge is shorter than the maximum width supported.
<b>Note:</b> An asterisk (*) next to a value indicates the factory default setting.	

### Custom Scan Sizes

Menu item	Description
<b>Custom Scan Size [x]</b> Scan Size Name Width 1–8.50 inches (8.50*) 25–216 mm (216*) Height 1–14 inches (14*) 25–356 mm (297*) Orientation Portrait* Landscape 2 scans per side Off* On	Assign a scan size name and configure the scan settings.

## Media Types

Menu item	Description
Plain Paper	Specify the texture and weight of the paper loaded. Select from the following options: Paper Texture Smooth Normal* Rough Paper Weight Light Normal* Heavy
Card Stock	
Transparency	
Recycled	
Labels	
Bond	
Envelope	
Rough Envelope	
Letterhead	
Preprinted	
Colored Paper	
Light	
Heavy	
Rough/Cotton	
Custom Type [x]	

**Note:** An asterisk (\*) next to a value indicates the factory default setting.

## Copy

### Copy Defaults

Menu item	Description
<b>Content Type</b> Text Text/Photo* Photo Graphics	Improve the output result based on the content of the original document.
<b>Content Source</b> Black and White Laser* Color Laser Inkjet Photo/Film Magazine Newspaper Press Other	

**Note:** An asterisk (\*) next to a value indicates the factory default setting.

Menu item	Description
<b>Sides</b> 1 sided to 1 sided* 1 sided to 2 sided 2 sided to 1 sided 2 sided to 2 sided	Specify the scanning behavior based on the original document.
<b>Separator Sheets</b> None* Between Copies Between Jobs Between Pages	Specify whether to insert blank separator sheets when printing.
<b>Separator Sheet Source</b> Tray [x] (1*) Multipurpose Feeder	Specify the paper source for the separator sheet.
<b>Pages per Side</b> Off* 2 Portrait pages 4 Portrait pages 2 Landscape pages 4 Landscape pages	Specify the number of page images to print on one side of a sheet of paper.
<b>Print Page Borders</b> Off* On	Place a border around each image when printing multiple pages on a single page.
<b>Collate</b> Off [1,1,1,2,2,2] On [1,2,1,2,1,2]*	Print multiple copies in sequence.
<b>“Copy from” Size</b> [List of paper sizes]	Set the paper size of the original document.  <b>Notes:</b> <ul style="list-style-type: none"> <li>• Letter is the U.S. factory default setting. A4 is the international factory default setting.</li> <li>• This menu item may vary depending on your printer model.</li> </ul>
<b>“Copy to” Source</b> Tray [x] (1*) Multipurpose Feeder Auto Size Match	Specify the paper source for the copy job.
<b>Darkness</b> -4 to 4 (0*)	Adjust the darkness of the scanned image.
<b>Number of Copies</b> 1–9999 (1*)	Specify the number of copies.
<b>Note:</b> An asterisk (*) next to a value indicates the factory default setting.	

Menu item	Description
<b>Header/Footer</b> Top left Top middle Top right Bottom left Bottom middle Bottom right	Apply a header or footer on the printed output.
<b>Overlay</b> Confidential Copy Draft Urgent Custom Off*	Specify the overlay text printed on each page of the copy job.
<b>Custom overlay</b>	Type a custom overlay text.
<b>Note:</b> An asterisk (*) next to a value indicates the factory default setting.	

**Advanced Imaging**

Menu item	Description
<b>Color Dropout</b> None* Red Green Blue  <b>Default Red Threshold</b> 0–255 (128*)  <b>Default Green Threshold</b> 0–255 (128*)  <b>Default Blue Threshold</b> 0–255 (128*)	Specify which color to drop during scanning, and adjust the dropout setting for that color.
<b>Contrast</b> Best for Content* 0 1 2 3 4 5	Specify the contrast of the output.
<b>Note:</b> An asterisk (*) next to a value indicates the factory default setting.	



Menu item	Description
<b>Background Removal</b> Background Detection Level	Adjust the amount of background visible on a scanned image.
<b>Auto Center</b> Off* On	Align the content at the center of the page.
<b>Mirror Image</b> Off* On	Create a mirror image of the original document.
<b>Negative Image</b> Off* On	Create a negative image of the original document.
<b>Shadow Detail</b> -4 to 4 (0*)	Adjust the amount of shadow detail visible on a scanned image.
<b>Scan Edge to Edge</b> Off* On	Allow edge-to-edge scanning of the original document.
<b>Sharpness</b> 1–5 (3*)	Adjust the sharpness of a scanned image.
<b>Note:</b> An asterisk (*) next to a value indicates the factory default setting.	

### Admin Controls

Menu item	Description
<b>Transparency Separators</b> Off On*	Insert a blank sheet between transparencies.
<b>Allow Priority Copies</b> Off On*	Interrupt a print job to copy a page or document.
<b>Custom Job Scanning</b> Off* On	Turn on scanning of custom jobs by default.
<b>Allow Save as Shortcut</b> Off On*	Save custom copy settings as shortcuts.
<b>Sample Copy</b>	Print a sample copy.
<b>Note:</b> An asterisk (*) next to a value indicates the factory default setting.	

# Fax

## Fax Mode

Menu item	Description
<b>Fax Mode</b> Analog* Fax Server Disabled	Select a fax mode.
<b>Note:</b> An asterisk (*) next to a value indicates the factory default setting.	

## Analog Fax Setup

### General Fax Settings

Menu item	Description
<b>Fax Name</b>	Identify your fax machine.
<b>Fax Number</b>	Identify your fax number.
<b>Fax ID</b> Fax Name Fax Number*	Notify fax recipients of your fax name or fax number.
<b>Enable Manual Fax</b> Off* On	Set the printer to fax manually.  <b>Notes:</b> <ul style="list-style-type: none"> <li>• This menu item does not appear if Fax Transport is set to T.38 or G711.</li> <li>• This menu item requires a line splitter and a telephone handset.</li> <li>• Use a regular telephone line to answer an incoming fax job and to dial a fax number.</li> <li>• To go directly to the Manual Fax function, touch # and 0 on the keypad.</li> </ul>
<b>Memory Use</b> All receive Mostly receive Equal* Mostly send All send	Set the amount of internal printer memory allocated for faxing.  <b>Note:</b> This menu item prevents memory buffer conditions and failed faxes.
<b>Cancel Faxes</b> Allow* Don't Allow	Cancel outgoing faxes before they are transmitted, or cancel incoming faxes before they finish printing.
<b>Note:</b> An asterisk (*) next to a value indicates the factory default setting.	

Menu item	Description
<b>Caller ID</b> Off On* Alternate	Show the telephone number of the person sending the fax.
<b>Fax Number Masking</b> Off* From Left From Right	Specify the format for masking an outgoing fax number.
<b>Digits to Mask</b> 0–58 (0*)	Specify the number of digits to mask in an outgoing fax number.
<b>Enable Line Connected Detection</b> Off On*	Determine whether a telephone line is connected to the printer. <b>Notes:</b> <ul style="list-style-type: none"> <li>• Detection takes place when turning on the printer and before each call.</li> <li>• This menu item does not appear if Fax Transport is set to T.38.</li> </ul>
<b>Enable Line In Wrong Jack Detection</b> Off* On	Determine whether a telephone line is connected to the correct port on the printer. <b>Notes:</b> <ul style="list-style-type: none"> <li>• Detection takes place when turning on the printer and before each call.</li> <li>• This menu item does not appear if Fax Transport is set to T.38.</li> </ul>
<b>Enable Extension in Use Support</b> Off On*	Determine whether a telephone line is used by another device such as another phone on the same line. <b>Notes:</b> <ul style="list-style-type: none"> <li>• This menu item is monitored continuously after turning on the printer.</li> <li>• This menu item does not appear if Fax Transport is set to T.38.</li> </ul>
<b>Optimize Fax Compatibility</b>	Configure the printer fax functionality for optimal compatibility with other fax machines.
<b>Note:</b> An asterisk (*) next to a value indicates the factory default setting.	

### Fax Send Settings

Menu item	Description
<b>Resolution</b> Standard* Fine Super Fine Ultra Fine	Set the resolution of the scanned image. <b>Note:</b> A higher resolution increases fax transmission time and requires higher memory.
<b>Original Size</b> [List of paper sizes]	Specify the size of the original document. <b>Note:</b> Mixed Sizes is the U.S. factory default setting. A4 is the international factory default setting.
<b>Note:</b> An asterisk (*) next to a value indicates the factory default setting.	

Menu item	Description
<b>Orientation</b> Portrait* Landscape	Specify the orientation of the original document.
<b>Sides</b> Off* Long Edge Short Edge	Specify the page orientation of text and graphics when scanning a two-sided document.
<b>Content Type</b> Text* Text/Photo Photo Graphics	Improve the output result based on the content of the original document.
<b>Content Source</b> Black and White Laser Color Laser* Inkjet Photo/Film Magazine Newspaper Press Other	Improve the output result based on the source of the original document.
<b>Darkness</b> 1–9 (5*)	Adjust the darkness of the scanned image.
<b>Behind a PABX</b> On Off*	Set the printer to dial a fax number without waiting to recognize the dial tone. <b>Note:</b> Private Automated Branch Exchange (PABX) is a telephone network that allows a single access number to offer multiple lines to outside callers.
<b>Dial Mode</b> Tone* Pulse	Specify the dial mode for incoming or outgoing faxes.
<b>Note:</b> An asterisk (*) next to a value indicates the factory default setting.	

**Advanced Imaging**

Menu item	Description
<b>Color Dropout</b> None* Red Green Blue  <b>Default Red Threshold</b> 0–255 (128*)  <b>Default Green Threshold</b> 0–255 (128*)  <b>Default Blue Threshold</b> 0–255 (128*)	Specify which color to drop during scanning, and adjust the dropout setting for that color.
<b>Contrast</b> Best for Content* 0 1 2 3 4 5	Set the contrast of the output.
<b>Background Removal</b> Background Detection Content-based* Fixed Level -4 to 4 (0*)	Adjust the amount of background visible on a scanned image.  <b>Note:</b> If you want to remove the background color from the original document, then set Background Detection to Content-based. If you want to remove image noise from a photo, then set Background Detection to Fixed.
<b>Mirror Image</b> On Off*	Create a mirror image of the original document.
<b>Negative Image</b> On Off*	Create a negative image of the original document.
<b>Shadow Detail</b> -4 to 4 (0*)	Adjust the amount of shadow detail visible on a scanned image.
<b>Scan Edge to Edge</b> On Off*	Allow edge-to-edge scanning of the original document.
<b>Sharpness</b> 1–5 (3*)	Adjust the sharpness of the scanned image.
<b>Note:</b> An asterisk (*) next to a value indicates the factory default setting.	

Menu item	Description
<b>Temperature</b> -4 to 4 (0*)	Specify whether to generate a cooler or warmer output.
<b>Note:</b> An asterisk (*) next to a value indicates the factory default setting.	

**Admin Controls**

Menu item	Description
<b>Automatic Redial</b> 0–9 (5*)	Adjust the number of redial attempts based on the activity levels of recipient fax machines.
<b>Redial Frequency</b> 1–200 minutes (3*)	Increase the time between redial attempts to increase the chance of sending fax successfully.
<b>Enable ECM</b> On* Off	Activate Error Correction Mode (ECM) for fax jobs. <b>Note:</b> ECM detects and corrects errors in the fax transmission process that are caused by telephone line noise and poor signal strength.
<b>Enable Fax Scans</b> On* Off	Fax documents that are scanned at the printer.
<b>Driver to Fax</b> On* Off	Allow the print driver to send fax.
<b>Allow Save as Shortcut</b> On* Off	Save fax numbers as shortcuts in the printer.
<b>Max Speed</b> 33600* 14400 9600 4800 2400	Set the maximum speed for sending fax.
<b>Enable Color Fax Scans</b> Off by default* On by default Never use Always use	Enable color scans for fax.
<b>Auto Convert Color Faxes to Mono Faxes</b> On* Off	Convert all outgoing color faxes to black and white.
<b>Confirm Fax Number</b> Off* On	Ask the user to confirm the fax number.
<b>Note:</b> An asterisk (*) next to a value indicates the factory default setting.	

Menu item	Description
<b>Dial Prefix</b>	Set a dialing prefix.
<b>Note:</b> An asterisk (*) next to a value indicates the factory default setting.	

## Fax Receive Settings

Menu item	Description
<b>Fax Job Waiting</b> None* Toner Toner and Supplies	Remove fax jobs that request specific unavailable resources from the print queue.
<b>Rings to Answer</b> 1–25 (3*)	Set the number of rings for incoming fax.
<b>Auto Reduction</b> On* Off	Scale incoming fax to fit on the page.
<b>Paper Source</b> Tray [x] MP Feeder Auto*	Set the paper source for printing incoming fax.
<b>Sides</b> On Off*	Print on both sides of the paper.
<b>Separator Sheets</b> Off* Before Job After Job	Specify whether to insert blank separator sheets when printing.
<b>Separator Sheet Source</b> Tray [x] (1*) MP Feeder	Specify the paper source for the separator sheet.
<b>Output Bin</b> Standard Bin* Bin [x]	Specify the output bin for received faxes.
<b>Fax Footer</b> On Off*	Print the transmission information at the bottom of each page from a received fax.
<b>Fax Footer Time Stamp</b> Receive* Print	Print the time stamp at the bottom of each page from a received fax.
<b>Note:</b> An asterisk (*) next to a value indicates the factory default setting.	

Menu item	Description
<b>Holding Faxes</b> Held Fax Mode Off* Always On Manual Scheduled	Hold received faxes from printing until they are released.
<b>Note:</b> An asterisk (*) next to a value indicates the factory default setting.	

**Admin Controls**

Menu item	Description
<b>Enable Fax Receive</b> On* Off	Set the printer to receive fax.
<b>Enable Caller ID</b> Off On*	Show the number that is sending the incoming fax.
<b>Block No Name Fax</b> On Off*	Block incoming faxes sent from devices with no station ID or fax ID specified.
<b>Banned Fax List</b> Add Banned Fax	Specify the phone numbers that you want to block.
<b>Answer On</b> All Rings* Single Ring Only Double Ring Only Triple Ring Only Single or Double Rings Only Single or Triple Rings Only Double or Triple Rings Only	Set a distinctive ring pattern for incoming fax.
<b>Auto Answer</b> On* Off	Set the printer to receive fax automatically.
<b>Manual Answer Code</b> 0–9 (9*)	Manually enter a code on the telephone number pad to begin receiving fax.  <b>Notes:</b> <ul style="list-style-type: none"> <li>• This menu item appears only when the printer shares a line with a telephone.</li> <li>• This menu item appears only when you set the printer to receive fax manually.</li> </ul>
<b>Note:</b> An asterisk (*) next to a value indicates the factory default setting.	



Menu item	Description
<b>Fax Forwarding</b> Print Print and Forward Forward*	Specify how to forward received fax.
<b>Forward to</b> Destination [x] Type Shortcut Number	Specify where to forward received fax.
<b>Confirmation E-mail</b>	Send a confirmation e-mail when fax forwarding is successful. <b>Note:</b> The e-mail is sent only when forwarding to FTP or Network Share destinations.
<b>Max Speed</b> 33600* 14400 9600 4800 2400	Set the maximum speed for transmitting fax.
<b>Note:</b> An asterisk (*) next to a value indicates the factory default setting.	

## Fax Cover Page

Menu item	Description
<b>Fax Cover Page</b> Off by Default* On by Default Never Use Always Use	Configure the settings for the fax cover page.
<b>Include To field</b> Off* On	
<b>Include From field</b> Off* On	
<b>From</b>	
<b>Include Message Field</b> Off* On	
<b>Message:</b>	
<b>Include Logo</b> Off* On	
<b>Include Footer [x]</b> Off* On	
<b>Footer [x]</b>	
<b>Note:</b> An asterisk (*) next to a value indicates the factory default setting.	

## Fax Log Settings

Menu item	Description
<b>Transmission Log</b> Print log* Do Not Print Log Print Only For Error	Print a log for successful fax transmission or transmission error.
<b>Receive Error Log</b> Print Never* Print on Error	
<b>Auto Print Logs</b> On* Off	
<b>Note:</b> An asterisk (*) next to a value indicates the factory default setting.	

Menu item	Description
<b>Log Paper Source</b> Tray [x] (1*) Multipurpose Feeder	Specify the paper source for printing logs.
<b>Logs Display</b> Remote Fax Name* Dialed Number	Identify the sender by remote fax name or fax number.
<b>Enable Job Log</b> On* Off	View a summary of all fax jobs.
<b>Enable Call Log</b> On* Off	View a summary of fax dialing history.
<b>Log Output Bin</b> Standard Bin* Bin [x]	Specify the output bin for printed logs.
<b>Note:</b> An asterisk (*) next to a value indicates the factory default setting.	

## Speaker Settings

Menu item	Description
<b>Speaker Mode</b> Always Off Always On On until Connected*	Set the fax speaker mode.
<b>Speaker Volume</b> Low* High	Adjust the fax speaker volume.
<b>Ringer Volume</b> Off On*	Enable the ringer volume.
<b>Note:</b> An asterisk (*) next to a value indicates the factory default setting.	

## Fax Server Setup

### General Fax Settings

Menu item	Description
<b>To Format</b>	Specify a fax recipient.  <b>Note:</b> If you want to use the fax number, then type the number sign (#) before a number.
<b>Note:</b> An asterisk (*) next to a value indicates the factory default setting.	

Menu item	Description
<b>Reply Address</b>	Specify a reply address for sending fax.
<b>Subject</b>	Specify the fax subject and message.
<b>Message</b>	
<b>Enable analog receive</b> Off* On	Set the printer to receive analog faxes.
<b>Note:</b> An asterisk (*) next to a value indicates the factory default setting.	

### Fax Server E-mail Settings

Menu item	Description
<b>Primary SMTP Gateway</b>	Type the IP address or host name of the primary Simple Mail Transfer Protocol (SMTP) server for sending e-mail.
<b>Primary SMTP Gateway Port</b> 1–65535 (25*)	Enter the port number of the primary SMTP server.
<b>Secondary SMTP Gateway</b>	Type the server IP address or host name of your secondary or backup SMTP server.
<b>Secondary SMTP Gateway Port</b> 1–65535 (25*)	Enter the server port number of your secondary or backup SMTP server.
<b>SMTP Timeout</b> 5–30 (30*)	Set the time before the printer times out if the SMTP server does not respond.
<b>Reply Address</b>	Specify a reply address for sending fax.
<b>Always use SMTP default Reply Address</b> Off On*	Specify the SMTP reply address for sending fax.
<b>Use SSL/TLS</b> Disabled* Negotiate Required	Specify whether to send fax using an encrypted link.
<b>Require Trusted Certificate</b> Off On*	Specify a trusted certificate when accessing the SMTP server.
<b>SMTP Server Authentication</b> No authentication required* Login / Plain NTLM CRAM-MD5 Digest-MD5 Kerberos 5	Set the authentication type for the SMTP server.
<b>Note:</b> An asterisk (*) next to a value indicates the factory default setting.	

Menu item	Description
<b>Device-Initiated E-mail</b> None* Use Device SMTP Credentials	Specify whether credentials are required for device-initiated e-mail.
<b>User-Initiated E-mail</b> None* Use Device SMTP Credentials Use Session User ID and Password Use Session E-mail address and Password Prompt user	Specify whether credentials are required for user-initiated e-mail.
<b>Use Active Directory Device Credentials</b> Off On*	Enable user credentials and group destinations to connect to the SMTP server.
<b>Device Userid</b>	Specify the user ID and password to connect to the SMTP server.
<b>Device Password</b>	
<b>Kerberos 5 REALM</b>	Specify the realm for the Kerberos 5 authentication protocol.
<b>NTLM Domain</b>	Specify the domain name for the NTLM security protocol.
<b>Disable "SMTP server not set up" error</b> Off* On	Hide the "SMTP server not set up" error message.
<b>Note:</b> An asterisk (*) next to a value indicates the factory default setting.	

### Fax Server Scan Settings

Menu item	Description
<b>Image Format</b> TIFF (.tif) PDF (.pdf)* XPS (.xps) TXT (.txt) RTF (.rtf) DOCX (.docx)	Specify the file format for the scanned image.
<b>Content Type</b> Text Text/Photo* Photo Graphics	Improve the output result based on the content of the original document.
<b>Note:</b> An asterisk (*) next to a value indicates the factory default setting.	

Menu item	Description
<b>Content Source</b> Black and White Laser Color Laser* Inkjet Photo/Film Magazine Newspaper Press Other	Improve the output result based on the source of the original document.
<b>Fax Resolution</b> Standard* Fine Super Fine Ultra Fine	Set the fax resolution.
<b>Darkness</b> 1–9 (5*)	Set the darkness of the output.
<b>Orientation</b> Portrait* Landscape	Specify the orientation of text and graphics on the page.
<b>Original Size</b> [List of paper sizes]	Set the paper size of the original document.  <b>Notes:</b> <ul style="list-style-type: none"> <li>• Mixed Sizes is the U.S. factory default setting. A4 is the international factory default setting.</li> <li>• This setting may vary depending on your printer model.</li> </ul>
<b>Use Multi-Page TIFF</b> Off On*	Choose between single- and multiple-page TIFF files.
<b>Note:</b> An asterisk (*) next to a value indicates the factory default setting.	

## E-mail

### E-mail Setup

Menu item	Description
<b>Primary SMTP Gateway</b>	Type the IP address or host name of the primary SMTP server for sending e-mail.
<b>Primary SMTP Gateway Port</b> 1–65535 (25*)	Enter the port number of the primary SMTP server.
<b>Note:</b> An asterisk (*) next to a value indicates the factory default setting.	

Menu item	Description
<b>Secondary SMTP Gateway</b>	Type the server IP address or host name of your secondary or backup SMTP server.
<b>Secondary SMTP Gateway Port</b> 1–65535 (25*)	Enter the server port number of your secondary or backup SMTP server.
<b>SMTP Timeout</b> 5–30 seconds (30*)	Set the time before the printer times out if the SMTP server does not respond.
<b>Reply Address</b>	Specify a reply address in the e-mail.
<b>Always use SMTP default Reply Address</b> On* Off	Always use the default reply address in the SMTP server.
<b>Use SSL/TLS</b> Disabled* Negotiate Required	Specify whether to send e-mail using an encrypted link.
<b>Require Trusted Certificate</b> Off On*	Require a trusted certificate when accessing the SMTP server.
<b>SMTP Server Authentication</b> No authentication required* Login / Plain NTLM CRAM-MD5 Digest-MD5 Kerberos 5	Set the authentication type for the SMTP server.
<b>Device-Initiated E-mail</b> None* Use Device SMTP Credentials	Specify whether credentials are required for device-initiated e-mail.
<b>User-Initiated E-mail</b> None* Use Device SMTP Credentials Use Session User ID and Password Use Session E-mail address and Password Prompt user	Specify whether credentials are required for user-initiated e-mail.
<b>Use Active Directory Device Credentials</b> Off On*	Enable user credentials and group designations to connect to the SMTP server.

**Note:** An asterisk (\*) next to a value indicates the factory default setting.

Menu item	Description
<b>Device Userid</b>	Specify the user ID and password to connect to the SMTP server.
<b>Device Password</b>	
<b>Kerberos 5 REALM</b>	Specify the realm for the Kerberos 5 authentication protocol.
<b>NTLM Domain</b>	Specify the domain name for the NTLM security protocol.
<b>Disable "SMTP server not set up" error</b> Off* On	Hide the "SMTP server not set up" error message.
<b>Note:</b> An asterisk (*) next to a value indicates the factory default setting.	

## E-mail Defaults

Menu item	Description
<b>Subject</b>	Specify the e-mail subject and message.
<b>Message</b>	
<b>File Name</b>	Specify the file name for the scanned image.
<b>Format</b> PDF (.pdf)* TIFF (.tif) JPEG (.jpg) XPS (.xps) TXT (.txt) RTF (.rtf) DOC (.docx)	Specify the file format for the scanned image.
<b>Global OCR Settings</b> Recognized Languages Auto Rotate Despeckle Auto Contrast Enhance	Configure the settings for optical character recognition (OCR). <b>Note:</b> This menu item appears only if you have purchased and installed an OCR solution.
<b>Note:</b> An asterisk (*) next to a value indicates the factory default setting.	



Menu item	Description
<b>PDF Settings</b> PDF Version 1.3 1.4 1.5* 1.6 1.7 Archival Version A-1a* A-1b Highly Compressed Off* On Secure Off* On Searchable Off* On Archival (PDF/A) Off* On	Set the PDF format of the scanned image.
<b>Content Type</b> Text Text/Photo* Photo Graphics	Improve the output result based on the content of the original document.
<b>Content Source</b> Black and White Laser* Color Laser Inkjet Photo/Film Magazine Newspaper Press Other	Improve the output result based on the original document.
<b>Color</b> Black and White Gray Color* Auto	Specify the color when scanning an image.
<b>Note:</b> An asterisk (*) next to a value indicates the factory default setting.	

Menu item	Description
<b>Resolution</b> 75 dpi 150 dpi* 200 dpi 300 dpi 400 dpi 600 dpi	Set the resolution of the scanned image.
<b>Darkness</b> -4 to 4 (0*)	Adjust the darkness of the scanned image.
<b>Orientation</b> Portrait* Landscape	Specify the orientation of text and graphics on the page.
<b>Original Size</b> [List of paper sizes]	Set the paper size of the original document. <b>Note:</b> Mixed Sizes is the factory default setting.
<b>Sides</b> Off* Long Edge Short Edge	Specify the page orientation of text and graphics when scanning a two-sided document.
<b>Note:</b> An asterisk (*) next to a value indicates the factory default setting.	

**Advanced Imaging**

Menu item	Description
<b>Color Dropout</b> Color Dropout None* Red Green Blue Default Red Threshold 0–255 (128*) Default Green Threshold 0–255 (128*) Default Blue Threshold 0–255 (128*)	Specify which color to drop during scanning, and adjust the dropout setting for that color.
<b>Auto Color Detect</b> Color Sensitivity 1–9 (5*) Area Sensitivity 1–9 (5*)	Set the amount of color that the printer detects from the original document. <b>Note:</b> This menu item appears only when Color is set to Auto.
<b>Note:</b> An asterisk (*) next to a value indicates the factory default setting.	

Menu item	Description
<b>JPEG Quality</b> Best for content* 5–95	Set the quality of a JPEG-format scanned image.  <b>Notes:</b> <ul style="list-style-type: none"> <li>• 5 reduces the file size, but lessens the image quality.</li> <li>• 95 provides the best image quality, but produces a large file size.</li> </ul>
<b>Contrast</b> Best for content* 0 1 2 3 4 5	Specify the contrast of the output.
<b>Background Removal</b> Background Detection Content-based* Fixed Level -4 to 4 (0*)	Adjust the amount of background visible on a scanned image.  <b>Note:</b> If you want to remove the background color from the original document, then set Background Detection to Content-based. If you want to remove image noise from a photo, then set Background Detection to Fixed.
<b>Mirror Image</b> Off* On	Create a mirror image of the original document.
<b>Negative Image</b> Off* On	Create a negative image of the original document.
<b>Shadow Detail</b> -4 to 4 (0*)	Adjust the amount of shadow detail visible on a scanned image.
<b>Scan Edge to Edge</b> Off* On	Allow edge-to-edge scanning of the original document.
<b>Sharpness</b> 1–5 (3*)	Adjust the sharpness of a scanned image.
<b>Temperature</b> -4 to 4 (0*)	Specify whether to generate a cooler or warmer output.
<b>Blank Pages</b> Blank Page Removal Blank Page Sensitivity	Specify whether to include blank pages.
<b>Note:</b> An asterisk (*) next to a value indicates the factory default setting.	

## Admin Controls

Menu item	Description
<b>Max E-mail Size</b> 0–65535 (0*)	Set the allowable file size for each e-mail.
<b>Size Error Message</b>	Specify an error message that the printer sends when an e-mail exceeds its allowable file size. <b>Note:</b> You can type up to 1024 characters.
<b>Limit Destinations</b>	Limit sending of e-mail only to the specified list of domain names. <b>Note:</b> Use a comma to separate each domain.
<b>Send Me a Copy</b> Never appears* On by Default Off by Default Always On	Send a copy of the e-mail to yourself.
<b>Limit E-mail Recipients</b> Off* On	Limit the number of e-mail recipients.
<b>Use cc:/bcc:</b> Off* On	Enable carbon copy and blind carbon copy in e-mail.
<b>Use Multi-Page TIFF</b> On* Off	Choose between single- and multiple-page TIFF files.
<b>TIFF Compression</b> LZW* JPEG	Set a compression option for TIFF files.
<b>Text Default</b> 5–95 (75*)	Set the quality of text on a scanned image.
<b>Text/Photo Default</b> 5–95 (75*)	Set the quality of text or photo on a scanned image.
<b>Photo Default</b> 5–95 (50*)	Set the quality of a photo on a scanned image.
<b>E-mail Bit Depth</b> 1 bit 8 bit*	Enable the Text/Photo mode to produce smaller file sizes by using 1-bit image. <b>Note:</b> This menu item appears only when Color is set to Gray.
<b>Transmission Log</b> Print log* Do Not Print Log Print Only For Error	Print a log for successful e-mail transmission.
<b>Note:</b> An asterisk (*) next to a value indicates the factory default setting.	

Menu item	Description
<b>Log Paper Source</b> Tray [x] (1*) Multipurpose Feeder	Specify the paper source for printing logs.
<b>Custom Job Scanning</b> Off* On	Turn on scanning of custom jobs by default. <b>Note:</b> This menu item appears only when a hard disk is installed.
<b>Scan Preview</b> Off On*	Show the scan preview on the display. <b>Note:</b> This menu item appears only when a printer hard disk is installed.
<b>Allow Save as Shortcut</b> Off On*	Save e-mail addresses as shortcuts. <b>Note:</b> When set to Off, the Save As Shortcut button does not appear on the e-mail Destination screen.
<b>E-mail Images Sent As</b> Attachment* Web Link	Specify how to send the images in e-mail.
<b>Note:</b> An asterisk (*) next to a value indicates the factory default setting.	

## Web Link Setup

Menu item	Description
<b>Server</b>	Set the printer to send e-mail as a web link.
<b>Login</b>	
<b>Password</b>	
<b>Path</b>	
<b>File Name</b>	
<b>Web Link</b>	

## FTP

### FTP Defaults

Menu item	Description
<b>Format</b> PDF (.pdf)* TIFF (.tif) JPEG (.jpg) XPS (.xps)	Specify the file format for the scanned image.
<b>Note:</b> An asterisk (*) next to a value indicates the factory default setting.	

Menu item	Description
<p><b>PDF Settings</b></p> <ul style="list-style-type: none"> <li>PDF Version                             <ul style="list-style-type: none"> <li>1.3</li> <li>1.4</li> <li>1.5*</li> <li>1.6</li> <li>1.7</li> </ul> </li> <li>Archival Version                             <ul style="list-style-type: none"> <li>A-1a*</li> <li>A-1b</li> </ul> </li> <li>Secure                             <ul style="list-style-type: none"> <li>Off*</li> <li>On</li> </ul> </li> <li>Archival (PDF/A)                             <ul style="list-style-type: none"> <li>Off*</li> <li>On</li> </ul> </li> </ul>	<p>Set the PDF format for the scanned image.</p>
<p><b>Content Type</b></p> <ul style="list-style-type: none"> <li>Text</li> <li>Text/Photo*</li> <li>Graphics</li> <li>Photo</li> </ul>	<p>Improve the output result based on the content of the original document.</p>
<p><b>Content Source</b></p> <ul style="list-style-type: none"> <li>Black and White Laser</li> <li>Color Laser*</li> <li>Inkjet</li> <li>Photo/Film</li> <li>Magazine</li> <li>Newspaper</li> <li>Press</li> <li>Other</li> </ul>	<p>Improve the output result based on the source of the original document.</p>
<p><b>Color</b></p> <ul style="list-style-type: none"> <li>Black and White</li> <li>Gray</li> <li>Color*</li> <li>Auto</li> </ul>	<p>Specify the color when scanning an image.</p>
<p><b>Resolution</b></p> <ul style="list-style-type: none"> <li>75 dpi</li> <li>150 dpi*</li> <li>200 dpi</li> <li>300 dpi</li> <li>400 dpi</li> <li>600 dpi</li> </ul>	<p>Set the resolution of the scanned image.</p>
<p><b>Note:</b> An asterisk (*) next to a value indicates the factory default setting.</p>	

Menu item	Description
<b>Darkness</b> -4 to 4 (0*)	Adjust the darkness of the scanned image.
<b>Orientation</b> Portrait* Landscape	Specify the orientation of text and graphics on the page.
<b>Original Size</b> [List of paper sizes]	Set the paper size of the original document. <b>Notes:</b> <ul style="list-style-type: none"> <li>• Letter is the U.S. factory default setting. A4 is the international factory default setting.</li> <li>• The menu items may vary depending on your printer model.</li> </ul>
<b>Sides</b> Off* Long Edge Short Edge	Specify the page orientation of text and graphics when scanning a two-sided document.
<b>File Name</b>	Specify the file name of the scanned image.
<b>Note:</b> An asterisk (*) next to a value indicates the factory default setting.	

### Advanced Imaging

Menu item	Description
<b>Color Balance</b> -4 to 4 (0*)	Adjust the amount of toner used for each color in scan output.
<b>Color Dropout</b> Color Dropout None* Red Green Blue Default Red Threshold 0–255 (128*) Default Green Threshold 0–255 (128*) Default Blue Threshold 0–255 (128*)	Specify which color to drop during scanning, and adjust the dropout setting for that color.
<b>Auto Color Detect</b> Color Sensitivity 1–9 (5*) Area Sensitivity 1–9 (5*)	Set the amount of color that the printer detects from the original document. <b>Note:</b> This menu item appears only when Color is set to Auto.
<b>Note:</b> An asterisk (*) next to a value indicates the factory default setting.	

Menu item	Description
<b>JPEG Quality</b> Best for content* 5–95	Set the quality of a JPEG-format image. <b>Notes:</b> <ul style="list-style-type: none"> <li>• 5 reduces the file size, but lessens the image quality.</li> <li>• 90 provides the best image quality, but produces a large file size.</li> </ul>
<b>Contrast</b> Best for content* 0 1 2 3 4 5	Specify the contrast of the output.
<b>Background Removal</b> Background Detection Content-based* Fixed Level -4 to 4 (0*)	Adjust the amount of background visible on a scanned image. <b>Note:</b> If you want to remove the background color from the original document, then set Background Detection to Content-based. If you want to remove image noise from a photo, then set Background Detection to Fixed.
<b>Mirror Image</b> Off* On	Create a mirror image of the original document.
<b>Negative Image</b> Off* On	Create a negative image of the original document.
<b>Shadow Detail</b> -4 to 4 (0*)	Adjust the amount of shadow detail visible on a scanned image.
<b>Scan Edge to Edge</b> Off* On	Allow edge-to-edge scanning of the original document.
<b>Sharpness</b> 1–5 (3*)	Adjust the sharpness of a scanned image.
<b>Temperature</b> -4 to 4 (0*)	Specify whether to generate a cooler or warmer output.
<b>Blank Pages</b> Blank Page Removal Blank Page Sensitivity	Specify whether to include blank pages.
<b>Note:</b> An asterisk (*) next to a value indicates the factory default setting.	



## Admin Controls

Menu item	Description
<b>Text Default</b> 5–95 (75*)	Set the quality of text on a scanned image.
<b>Text/Photo Default</b> 5–95 (75*)	Set the quality of text or photo image on a scanned image.
<b>Photo Default</b> 5–95 (50*)	Set the quality of a photo image on a scanned image.
<b>Use Multi-Page TIFF</b> On* Off	Choose between single- and multiple-page TIFF files.
<b>TIFF Compression</b> LZW* JPEG	Set a compression option for TIFF files.
<b>Transmission Log</b> Print Log* Do Not Print Log Print Only For Error	Print a log for successful FTP scan transmission.
<b>Log Paper Source</b> Tray [x] (1*) Multipurpose Feeder	Specify the paper source for printing FTP logs.
<b>FTP Bit Depth</b> 1 bit 8 bit*	Enable the Text/Photo mode to have smaller file sizes by using 1-bit image. <b>Note:</b> This menu item appears only when Color is set to Gray.
<b>Custom Job Scanning</b> Off* On	Turn on scanning of custom jobs by default. <b>Note:</b> This menu item appears only when a hard disk is installed.
<b>Scan Preview</b> Off On*	Show a preview of the scan on the display. <b>Note:</b> This menu item appears only when a hard disk is installed.
<b>Allow Save as Shortcut</b> Off On*	Save custom FTP settings as shortcuts.
<b>Note:</b> An asterisk (*) next to a value indicates the factory default setting.	

# USB Drive

## Flash Drive Scan

Menu item	Description
<b>Format</b> PDF (.pdf)* TIFF (.tif) JPEG (.jpg) XPS (.xps)	Specify the file format for the scanned image.
<b>PDF Settings</b> PDF Version 1.3 1.4 1.5* 1.6 1.7 Archival Version A-1a* A-1b Secure Off* On Archival (PDF/A) Off* On	Set the PDF format for the scanned image.
<b>Content Type</b> Text Text/Photo* Graphics Photo	Improve the output result based on the content of the original document.
<b>Content Source</b> Black and White Laser Color Laser* Inkjet Photo/Film Magazine Newspaper Press Other	Improve the output result based on the source of the original document.
<b>Note:</b> An asterisk (*) next to a value indicates the factory default setting.	

Menu item	Description
<b>Color</b> Black and White Gray Color* Auto	Specify the color when scanning an image.
<b>Resolution</b> 75 dpi 150 dpi* 200 dpi 300 dpi 400 dpi 600 dpi	Set the resolution of the scanned image.
<b>Darkness</b> 1–9 (5*)	Adjust the darkness of the scanned image.
<b>Orientation</b> Portrait* Landscape	Specify the orientation of text and graphics on the page.
<b>Original Size</b> [List of paper sizes]	Set the paper size of the original document. <b>Notes:</b> <ul style="list-style-type: none"> <li>• Letter is the U.S. factory default setting. A4 is the international factory default setting.</li> <li>• These settings may vary depending on your printer model.</li> </ul>
<b>Sides</b> Off* Long edge Short edge	Specify the page orientation of text and graphics when scanning a two-sided document.
<b>File Name</b>	Specify the file name of the scanned image.
<b>Note:</b> An asterisk (*) next to a value indicates the factory default setting.	

## Advanced Imaging

Menu item	Description
<b>Color Dropout</b> Color Dropout None* Red Green Blue Default Red Threshold 0–255 (128*) Default Green Threshold 0–255 (128*) Default Blue Threshold 0–255 (128*)	Specify which color to drop during scanning, and adjust the dropout setting for that color.
<b>Auto Color Detect</b> Color Sensitivity 1–9 (5*) Area Sensitivity 1–9 (5*)	Set the amount of color that the printer detects from the original document. <b>Note:</b> This menu item appears only when Color is set to Auto.
<b>JPEG Quality</b> Best for content* 5–95	Set the quality of a JPEG-format image. <b>Notes:</b> <ul style="list-style-type: none"> <li>• 5 reduces the file size, but lessens the image quality.</li> <li>• 90 provides the best image quality, but produces a large file size.</li> </ul>
<b>Contrast</b> Best for content* 0 1 2 3 4 5	Specify the contrast of the output.
<b>Background Removal</b> -4 to 4 (0*)	Adjust the amount of background visible on a scanned image.
<b>Mirror Image</b> Off* On	Create a mirror image of the original document.
<b>Negative Image</b> Off* On	Create a negative image of the original document.
<b>Shadow Detail</b> -4 to 4 (0*)	Adjust the amount of shadow detail visible on a scanned image.
<b>Note:</b> An asterisk (*) next to a value indicates the factory default setting.	

Menu item	Description
<b>Scan Edge to Edge</b> Off* On	Allow edge-to-edge scanning of the original document.
<b>Sharpness</b> 1–5 (3*)	Adjust the sharpness of a scanned image.
<b>Temperature</b> -4 to 4 (0*)	Specify whether to generate a cooler or warmer output.
<b>Blank Pages</b> Blank Page Removal Blank Page Sensitivity	Specify whether to include blank pages.
<b>Note:</b> An asterisk (*) next to a value indicates the factory default setting.	

### Admin Controls

Menu item	Description
<b>Text Default</b> 5–95 (75*)	Set the quality of text on a scanned image.
<b>Text/Photo Default</b> 5–95 (75*)	Set the quality of text or photo on a scanned image.
<b>Photo Default</b> 5–95 (75*)	Set the quality of a photo on a scanned image.
<b>Use Multi-Page TIFF</b> On* Off	Choose between single- and multiple-page TIFF files.
<b>TIFF Compression</b> LZW* JPEG	Set the compression for TIFF files.
<b>Scan Bit Depth</b> 1 bit 8 bit*	Enable the Text/Photo mode to have smaller file sizes by using 1-bit image. <b>Note:</b> This menu item appears only when Color is set to Gray.
<b>Custom Job Scanning</b> Off* On	Turn on scanning of custom jobs by default. <b>Note:</b> This menu item appears only when a hard disk is installed.
<b>Scan Preview</b> Off On*	Show a preview of the scan on the display. <b>Note:</b> This menu item appears only when a formatted, working printer hard disk is installed.
<b>Note:</b> An asterisk (*) next to a value indicates the factory default setting.	

## Flash Drive Print

Menu item	Description
<b>Number of Copies</b> 1–9999 (1*)	Set the number of copies.
<b>Paper Source</b> Tray [x] (1*) Multipurpose Feeder Manual Paper Manual Envelope	Specify the paper source for the print job.
<b>Collate</b> Off [1,1,1,2,2,2] On [1,2,1,2,1,2]*	Print multiple copies in a sequence.
<b>Sides</b> 1-Sided* 2-Sided	Specify whether to print on one side or two sides of the paper.
<b>Flip Style</b> Long Edge* Short Edge	Determine which side of the paper (long edge or short edge) is bound when performing two-sided printing.  <b>Note:</b> Depending on the option selected, the printer automatically offsets each printed information of the page to bind the job correctly.
<b>Pages per Side</b> Off* 2-Up 3-Up 4-Up 6-Up 9-Up 12-Up 16-Up	Print multiple page images on a sheet of paper.
<b>Pages per Side Ordering</b> Horizontal* Reverse Horizontal Reverse Vertical Vertical	Specify the positioning of multiple page images when using Pages per Side.  <b>Note:</b> The positioning depends on the number of page images and their page orientation.
<b>Pages per Side Orientation</b> Auto* Landscape Portrait	Specify the orientation of a multiple-page document when using Pages per Side.
<b>Pages per Side Border</b> None* Solid	Print a border around each page image when using Pages per Side.
<b>Note:</b> An asterisk (*) next to a value indicates the factory default setting.	

Menu item	Description
<b>Separator Sheets</b> Off* Between Copies Between Jobs Between Pages	Specify whether to insert blank separator sheets when printing.
<b>Separator Sheet Source</b> Tray [x] (1*) Multipurpose Feeder	Specify the paper source for the separator sheet.  <b>Note:</b> For Multipurpose Feeder to appear, set Configure MP to Cassette from the Paper menu.
<b>Blank Pages</b> Do Not Print* Print	Specify whether to include blank pages in a print job.
<b>Note:</b> An asterisk (*) next to a value indicates the factory default setting.	

## Network/Ports

### Network Overview

Menu item	Description
<b>Active Adapter</b> Auto* Standard Network Wireless	Choose the network connection that the printer connects to.
<b>Network Status</b>	Show the connection status of the printer network.
<b>Display Network Status on Printer</b> Off On*	Show the network status on the display.
<b>Speed, Duplex</b>	Show the speed of the currently active network card.
<b>IPv4</b>	Show the IPv4 address.
<b>All IPv6 Addresses</b>	Show all IPv6 addresses.
<b>Reset Print Server</b> Start	Reset all active network connections to the printer.  <b>Note:</b> This setting removes all network configuration settings.
<b>Network Job Timeout</b> Off On* (90 seconds)	Set the time before the printer cancels a network print job.
<b>Banner Page</b> Off On*	Print a banner page.
<b>Note:</b> An asterisk (*) next to a value indicates the factory default setting.	

## Wireless

**Note:** This menu is available only in printers connected to a wireless network.

Menu item	Description
<b>Setup On Printer Panel</b> Choose Network Add Wi-Fi Network Network Name Network Mode Infrastructure* Ad hoc Wireless Security Mode Disabled* WEP WPA2/WPA - Personal WPA2 - Personal	Configure the wireless connection using the control panel.
<b>Wi-Fi Protected Setup</b> Start Push Button Method Start PIN Method	Establish a wireless network and enable network security.  <b>Notes:</b> <ul style="list-style-type: none"> <li>• Start Push-Button Method connects the printer to a wireless network when buttons on both the printer and the access point (wireless router) are pressed within a given period of time.</li> <li>• Start PIN Method connects the printer to a wireless network when a PIN on the printer is entered into the wireless settings of the access point.</li> </ul>
<b>Network Mode</b> BSS Type Infrastructure* Ad hoc Preferred Channel Number Auto* 1–11	Specify the network mode.  <b>Note:</b> Preferred Channel Number only appears if BSS Type is set to Ad hoc.
<b>Enable Wi-Fi Direct</b> On Off*	Set the printer to connect directly to Wi-Fi devices.
<b>Compatibility</b> 802.11b/g/n (2.4GHz)* 802.11a/b/g/n/ac (2.4GHz/5GHz) 802.11a/n/ac (5GHz)	Specify the wireless standard for the wireless network.  <b>Note:</b> 802.11a/b/g/n and 802.11a/n are selectable only if the Enable Wi-Fi Direct setting is disabled.
<b>Wireless Security Mode</b> Disabled* WEP WPA2/WPA - Personal WPA2 - Personal 802.1x - RADIUS	Set the type of security for connecting the printer to wireless devices.



Menu item	Description
<b>WEP Authentication Mode</b> Auto* Open Shared	Set the type of Wireless Encryption Protocol (WEP) used by the printer.  <b>Note:</b> This menu item appears only if Wireless Security Mode is set to WEP.
<b>Set WEP Key</b>	Specify a WEP password for secure wireless connection.
<b>WPA2/WPA - Personal</b> AES	Enable wireless security through Wi-Fi Protected Access (WPA).  <b>Note:</b> This menu item appears only if the Wireless Security Mode is set to WPA2/WPA-Personal or WPA2-Personal.
<b>Set Pre-Shared Key</b>	Set the password for secure wireless connection.
<b>WPA2 - Personal</b> AES	Enable wireless security through WPA2.  <b>Note:</b> This menu item appears only if the Wireless Security Mode is set to WPA2/WPA-Personal or WPA2-Personal.
<b>802.1x Encryption Mode</b> WPA+ WPA2*	Enable wireless security through 802.1x standard.  <b>Note:</b> This menu item appears only if the Wireless Security Mode is set to 802.1x - Radius.
<b>IPv4</b> Enable DHCP On* Off Set Static IP Address IP Address Netmask Gateway	Enable and configure IPv4 settings in the printer.
<b>IPv6</b> Enable IPv6 On* Off Enable DHCPv6 On Off* Stateless Address Autoconfiguration On* Off DNS Server Address Manually Assigned IPv6 Address Manually Assigned IPv6 Router Address Prefix All IPv6 Addresses All IPv6 Router Addresses	Enable and configure IPv6 settings in the printer.
<b>Network Address</b> UAA LAA	View the network addresses.

Menu item	Description
<b>PCL Smartswitch</b> On* Off*	Set the printer to switch automatically to PCL emulation when a print job requires it, regardless of the default printer language.  <b>Note:</b> If PCL SmartSwitch is off, then the printer does not examine incoming data and uses the default printer language specified in the Setup menu.
<b>PS Smartswitch</b> On* Off*	Set the printer to switch automatically to PS emulation when a print job requires it, regardless of the default printer language.  <b>Note:</b> If PS SmartSwitch is off, then the printer does not examine incoming data and uses the default printer language specified in the Setup menu.
<b>Job Buffering</b> On Off*	Temporarily store print jobs in the printer hard disk before printing.  <b>Note:</b> This menu item appears only when a hard disk is installed.
<b>Mac Binary PS</b> Auto* On	Set the printer to process Macintosh binary PostScript print jobs.  <b>Note:</b> On processes raw binary PostScript print jobs.

## Ethernet

Menu item	Description
<b>Network Speed</b>	Show the speed of an active network adapter.
<b>IPv4</b> Enable DHCP On* Off	Enable Dynamic Host Configuration Protocol (DHCP).  <b>Note:</b> DHCP is a standard protocol that allows a server to dynamically distribute IP addressing and configuration information to clients.
<b>IPv4</b> Set Static IP Address IP Address Netmask Gateway	Set the static IP address of your printer.
<b>Enable IPv6</b> On* Off	Configure IPv6 in the printer.
<b>Enable DHCPv6</b> On Off*	Run DHCPv6 in an IPv6 network.
<b>Stateless Address Autoconfiguration</b> On* Off	Set the network adapter to accept the automatic IPv6 address configuration entries provided by a router.
<b>Note:</b> An asterisk (*) next to a value indicates the factory default setting.	

Menu item	Description
<b>DNS Address</b>	Specify the DNS server address, IP address, and the router for IPv6 network.
<b>Manually Assigned IPv6 Address</b>	
<b>Manually Assigned IPv6 Router</b>	
<b>Address Prefix</b> 0–128 (64*)	
<b>All IPv6 Addresses</b>	Show all IP and router addresses used in an IPv6 network.
<b>All IPv6 Router Addresses</b>	
<b>Network Address</b> UAA LAA	Show the printer Media Access Control (MAC) addresses: Locally Administered Address (LAA) and Universally Administered Address (UAA). <b>Note:</b> You can change the printer LAA manually.
<b>PCL SmartSwitch</b> On* Off	Set the printer to switch automatically to PCL emulation when a print job requires it, regardless of the default printer language. <b>Note:</b> If PCL SmartSwitch is off, then the printer does not examine incoming data and uses the default printer language specified in the Setup menu.
<b>PS SmartSwitch</b> On* Off	Set the printer to switch automatically to PS emulation when a print job requires it, regardless of the default printer language. <b>Note:</b> If PS SmartSwitch is off, then the printer does not examine incoming data and uses the default printer language specified in the Setup menu.
<b>Mac Binary PS</b> Auto* On Off	Set the printer to process Macintosh binary PostScript print jobs. <b>Notes:</b> <ul style="list-style-type: none"> <li>• On processes raw binary PostScript print jobs.</li> <li>• Off filters print jobs using the standard protocol.</li> </ul>
<b>Energy Efficient Ethernet</b> On* Off	Reduce power consumption when the printer receives no data from the Ethernet network.
<b>Note:</b> An asterisk (*) next to a value indicates the factory default setting.	

## TCP/IP

**Note:** This menu appears only in network printers or printers attached to print servers.

Menu item	Description
<b>Set Hostname</b>	Set the current TCP/IP host name.
<b>Domain Name</b>	Set the domain name.
<b>Allow DHCP/BOOTP to update NTP server</b> On* Off	Allow the DHCP and BOOTP clients to update the NTP settings of the printer.
<b>Note:</b> An asterisk (*) next to a value indicates the factory default setting.	

Menu item	Description
<b>Zero Configuration Name</b>	Specify a service name for the zero configuration network.
<b>Enable Auto IP</b> On* Off	Assign an IP address automatically.
<b>DNS Address</b>	Specify the current Domain Name System (DNS) server address.
<b>Backup DNS Address</b>	Specify the backup DNS server addresses.
<b>Backup DNS Address 2</b>	
<b>Backup DNS Address 3</b>	
<b>Domain Search Order</b>	Specify a list of domain names to locate the printer and its resources that reside in different domains on the network.
<b>Enable DDNS</b> On* Off	Update Dynamic DNS settings.
<b>DDNS TTL</b>	Specify the current DDNS settings.
<b>Default TTL</b>	
<b>DDNS Refresh Time</b>	
<b>Enable mDNS</b> Off On*	Update multicast DNS settings.
<b>WINS Address</b>	Specify a server address for Windows Internet Name Service (WINS).
<b>Enable BOOTP</b> Off* On	Allow the BOOTP to assign a printer IP address.
<b>Restricted Server List</b>	Specify an IP address for the TCP connections. <b>Notes:</b> <ul style="list-style-type: none"> <li>• Use a comma to separate each IP address.</li> <li>• You can add up to 50 IP addresses.</li> </ul>
<b>Restricted Server List Options</b> Block All Ports* Block Printing Only Block Printing and HTTP Only	Specify how the IP addresses in the list can access the printer functionality.
<b>MTU</b>	Specify a maximum transmission unit (MTU) parameter for the TCP connections.
<b>Raw Print Port</b> 1–65535 (9100*)	Specify a raw port number for printers connected on a network.
<b>Outbound Traffic Maximum Speed</b> Off* 100 to 1000000	Enable the printer maximum transfer rate.
<b>Note:</b> An asterisk (*) next to a value indicates the factory default setting.	

Menu item	Description
<b>Enhanced TLS Security</b> On Off*	Enhance printer privacy and data integrity.
<b>Resolve Hostnames Using DNS</b> Off On*	Use DNS to resolve host names to IP addresses.
<b>Note:</b> An asterisk (*) next to a value indicates the factory default setting.	

## SNMP

**Note:** This menu appears only in network printers or printers that are attached to print servers.

Menu item	Description
<b>SNMP Versions 1 and 2c</b> Enabled Off On* Allow SNMP Set Off On* Enable PPM MIB Off On* SNMP Community	Configure Simple Network Management Protocol (SNMP) versions 1 and 2c to install print drivers and applications.
<b>Note:</b> An asterisk (*) next to a value indicates the factory default setting.	

Menu item	Description
<b>SNMP Version 3</b> Enabled Off On* Set Read/Write Credentials User Name Password Set Read-only Credentials User Name Password Authentication Hash MD5 SHA1* Minimum Authentication Level No Authentication, No Privacy Authentication, No Privacy Authentication, Privacy* Privacy Algorithm DES AES-128*	Configure SNMP version 3 to install and update printer security.
<b>Note:</b> An asterisk (*) next to a value indicates the factory default setting.	

## IPSec

**Note:** This menu appears only in network printers or printers that are attached to print servers.

Menu item	Description
<b>Enable IPSec</b> Off* On	Enable Internet Protocol Security (IPSec).
<b>Base Configuration</b> Default* Compatibility Secure	Set the IPSec base configuration.  <b>Note:</b> This menu item appears only when Enable IPSec is set to On.
<b>DH (Diffie-Hellman) Group Proposal</b> modp2048 (14)* modp3072 (15) modp4069 (16) modp6144 (17) modp8192 (18)	Set the IPSec encryption.  <b>Note:</b> This menu item appears only when Base Configuration is set to Compatibility.
<b>Note:</b> An asterisk (*) next to a value indicates the factory default setting.	

Menu item	Description
<b>IKE SA Lifetime (Hours)</b> 1 2 4 8 24*	Set the amount of time before a new authentication key is generated. <b>Note:</b> These menu items appear only when Base Configuration is set to Secure.
<b>IPSec SA Lifetime (Hours)</b> 1 2 4 8 24*	
<b>Proposed Encryption Method</b> 3DES AES*	Specify the encryption and authentication methods to connect to a network securely. <b>Note:</b> These menu items appear only when Base Configuration is set to Compatibility.
<b>Proposed Authentication Method</b> SHA1 SHA256* SHA512	
<b>IPSec Device Certificate</b>	Specify an IPSec certificate. <b>Note:</b> This menu item appears only when Base Configuration is set to Compatibility.
<b>Pre-Shared Key Authenticated Connections</b> Host [x] Address Key	Configure the authenticated connections of the printer. <b>Note:</b> These menu items appear only when Enable IPSec is set to On.
<b>Certificate Authenticated Connections</b> Host [x] Address[/subnet] Address[/subnet]	
<b>Note:</b> An asterisk (*) next to a value indicates the factory default setting.	

## 802.1x

**Note:** This menu appears only in network printers or printers that are attached to print servers.

Menu item	Description
<b>Active</b> Off* On	Let the printer join networks that require authentication before allowing access. <b>Note:</b> To configure the settings of this menu item, access the Embedded Web Server.
<b>Note:</b> An asterisk (*) next to a value indicates the factory default setting.	

## LPD Configuration

**Note:** This menu appears only in network printers or printers that are attached to print servers.

Menu item	Description
<b>LPD Timeout</b> 0–65535 seconds (90*)	Set the time-out value to stop the Line Printer Daemon (LPD) server from waiting indefinitely for hung or invalid print jobs.
<b>LPD Banner Page</b> Off* On	Print a banner page for all LPD print jobs. <b>Note:</b> A banner page is the first page of a print job used as a separator of print jobs and to identify the originator of the print job request.
<b>LPD Trailer Page</b> Off* On	Print a trailer page for all LPD print jobs. <b>Note:</b> A trailer page is the last page of a print job.
<b>LPD Carriage Return Conversion</b> Off* On	Enable carriage return conversion. <b>Note:</b> Carriage return is a mechanism that commands the printer to move the position of the cursor to the first position on the same line.
<b>Note:</b> An asterisk (*) next to a value indicates the factory default setting.	

## HTTP/FTP Settings

**Note:** This menu appears only in network printers or printers attached to print servers.

Menu item	Description
<b>Enable HTTP Server</b> Off On*	Access the Embedded Web Server to monitor and manage the printer.
<b>Enable HTTPS</b> Off On*	Configure the Hypertext Transfer Protocol Secure (HTTPS) settings.
<b>Enable FTP/TFTP</b> Off On*	Send files using FTP.
<b>Local Domains</b>	Specify domain names for HTTP and FTP servers. <b>Note:</b> This menu item appears only in some printer models.
<b>Note:</b> An asterisk (*) next to a value indicates the factory default setting.	



Menu item	Description
<b>HTTP Proxy IP Address</b>	Configure the HTTP and FTP server settings. <b>Note:</b> These menu items appear only in some printer models.
<b>FTP Proxy IP Address</b>	
<b>HTTP Default IP Port</b> 1–65535 (80*)	
<b>HTTPS Device Certificate</b>	
<b>FTP Default IP Port</b> 1–65535 (21*)	
<b>Timeout for HTTP/FTP Requests</b> 1–299 (30*)	Specify the amount of time before the server connection stops.
<b>Retries for HTTP/FTP Requests</b> 1–299 (3*)	Set the number of retries to connect to the HTTP/FTP server.
<b>Note:</b> An asterisk (*) next to a value indicates the factory default setting.	

## ThinPrint

Menu item	Description
<b>Enable ThinPrint</b> Off On*	Print using ThinPrint.
<b>Port Number</b> 4000–4999 (4000*)	Set the port number for the ThinPrint server.
<b>Bandwidth (bits/sec)</b> 0* 100–1000000	Set the speed to transmit data in a ThinPrint environment.
<b>Packet Size (kbytes)</b> 0–64000 (0*)	Set the packet size for data transmission.
<b>Note:</b> An asterisk (*) next to a value indicates the factory default setting.	

## USB

Menu item	Description
<b>PCL SmartSwitch</b> On* Off	Set the printer to switch to PCL emulation when a print job received through a USB port requires it, regardless of the default printer language. <b>Note:</b> If PCL SmartSwitch is off, then the printer does not examine incoming data and uses the default printer language specified in the Setup menu.
<b>Note:</b> An asterisk (*) next to a value indicates the factory default setting.	

Menu item	Description
<b>PS SmartSwitch</b> On* Off	Set the printer to switch to PS emulation when a print job received through a USB port requires it, regardless of the default printer language.  <b>Note:</b> If PS SmartSwitch is off, then the printer does not examine incoming data and uses the default printer language specified in the Setup menu.
<b>Mac Binary PS</b> Auto* On Off	Set the printer to process Macintosh binary PostScript print jobs.  <b>Notes:</b> <ul style="list-style-type: none"> <li>• On processes raw binary PostScript print jobs.</li> <li>• Off filters print jobs using the standard protocol.</li> </ul>
<b>Enable USB Port</b> Enable* Disable	Enable the standard USB port.
<b>Note:</b> An asterisk (*) next to a value indicates the factory default setting.	

## Google Cloud Print

Menu item	Description
<b>Registration</b> Register	Register the printer to the Google Cloud server.
<b>Options</b> Enable Google Cloud Print Off On*	Print directly from your Google account.
<b>Options</b> Enable Local Discovery Off On*	Allow higher bandwidth for data transmission.
<b>Options</b> Enable SSL Peer Verification Off On*	Verify authenticity of the peer certificate to connect to your Google account.
<b>Options</b> Always Print As Image Off* On	Save the scanned output into image files.
<b>Note:</b> An asterisk (*) next to a value indicates the factory default setting.	

## Wi-Fi Direct

**Note:** This menu appears only when a direct Wi-Fi network is the active network.

Menu item	Description
<b>SSID</b>	Specify the service set identifier (SSID) of the Wi-Fi network.
<b>Set Preshared Key</b>	Set the preshared key (PSK) to authenticate and validate users on a Wi-Fi connection.
<b>Show PSK on Setup Page</b> On* Off	Show the PSK on the Network Setup Page.
<b>Group Owner IP Address</b>	Specify the IP address of the group owner.
<b>Auto-Accept Push Button Requests</b> On Off*	Accept requests to connect to the network automatically. <b>Note:</b> Accepting clients automatically is not secured.
<b>Note:</b> An asterisk (*) next to a value indicates the factory default setting.	

## Security

### Login Methods

### Manage Permissions

Menu item	Description
<b>Function Access</b> Access Address Book in Apps Modify Address Book Manage Shortcuts Create Profiles Manage Bookmarks Flash Drive Print Flash Drive Scan Copy Function Color Dropout E-mail Function Fax Function FTP Function Release Held Faxes Held Jobs Access User Profiles Cancel Jobs at the Device Change Language Internet Printing Protocol (IPP) Initiate Scans Remotely B/W Print	Control access to the printer functions.

Menu item	Description
<p><b>Administrative Menus</b></p> <ul style="list-style-type: none"> <li>Security Menu</li> <li>Network/Ports Menu</li> <li>Paper Menu</li> <li>Reports Menu</li> <li>Function Configuration Menus</li> <li>Supplies Menu</li> <li>Option Card Menu</li> <li>SE Menu</li> <li>Device Menu</li> </ul>	<p>Control access to the printer menu settings.</p>
<p><b>Device Management</b></p> <ul style="list-style-type: none"> <li>Remote Management</li> <li>Firmware Updates</li> <li>Apps Configuration</li> <li>Operator Panel Lock</li> <li>Import/Export All Settings</li> <li>Out of Service Erase</li> </ul>	<p>Control access to the printer management options.</p>
<p><b>Apps</b></p> <ul style="list-style-type: none"> <li>New Apps</li> <li>Slideshow</li> <li>Change Wallpaper</li> <li>Screen Saver</li> <li>Card Copy</li> <li>Scan Center</li> <li>Scan Center Custom 1</li> <li>Scan Center Custom 2</li> <li>Scan Center Custom 3</li> <li>Scan Center Custom 4</li> <li>Scan Center Custom 5</li> <li>Scan Center Custom 6</li> <li>Scan Center Custom 7</li> <li>Scan Center Custom 8</li> <li>Scan Center Custom 9</li> <li>Scan Center Custom 10</li> <li>Forms and Favorites</li> </ul>	<p>Control access to printer applications.</p>

## Local Accounts

Menu item	Description
<b>Manage Groups/Permissions</b> Add Group Import Access Controls Function Access Administrative Menus Device Management Apps All Users Import Access Controls Function Access Administrative Menus Device Management Apps Admin	Control group or user access to the printer functions, applications, and security settings.
<b>Add User</b> User Name/Password User Name Password PIN	Create local accounts to manage access to the printer functions.
<b>User Name/Password Accounts</b> Add User	
<b>User Name Accounts</b> Add User	
<b>Password Accounts</b> Add User	
<b>PIN Accounts</b> Add User	

## Schedule USB Devices

Menu item	Description
<b>Schedules</b> Add New Schedule	Schedule access to the USB ports.

## Security Audit Log

Menu item	Description
<b>Enable Audit</b> Off* On	Record the events in the secure audit log and remote syslog.
<b>Enable Remote Syslog</b> Off* On	Send audit logs to a remote server.
<b>Remote Syslog Server</b>	Specify the remote syslog server and port.
<b>Remote Syslog Port</b> 1–65535 (514*)	
<b>Remote Syslog Method</b> Normal UDP* Stunnel	Specify a syslog method to transmit logged events to a remote server.
<b>Remote Syslog Facility</b> 0 - Kernel Messages 1 - User-Level Messages 2 - Mail System 3 - System Daemons 4 - Security/Authorization Messages* 5 - Messages Generated Internally by Syslogs 6 - Line Printer Subsystem 7 - Network News Subsystem 8 - UUCP Subsystem 9 - Clock Daemon 10 - Security/Authorization Messages 11 - FTP Daemon 12 - NTP Subsystem 13 - Log Audit 14 - Log Alert 15 - Clock Daemon 16 - Local Use 0 (local0) 17 - Local Use 1 (local1) 18 - Local Use 2 (local2) 19 - Local Use 3 (local3) 20 - Local Use 4 (local4) 21 - Local Use 5 (local5) 22 - Local Use 6 (local6) 23 - Local Use 7 (local7)	Specify a facility code that the printer uses when sending log events to a remote server.
<b>Note:</b> An asterisk (*) next to a value indicates the factory default setting.	

Menu item	Description
<b>Severity of Events to Log</b> 0 - Emergency 1 - Alert 2 - Critical 3 - Error 4 - Warning* 5 - Notice 6 - Informational 7 - Debug	Specify the priority level cutoff for logging messages and events.  <b>Notes:</b> <ul style="list-style-type: none"> <li>• 0 - Emergency is the highest severity. 7 - Debug is the lowest.</li> <li>• The selected severity level and anything higher are logged. For example, selecting 4 - Warning logs the severity levels from 0 to 4.</li> </ul>
<b>Remote Syslog Non-Logged Events</b> Off* On	Send all events, regardless of severity level, to the remote server.
<b>Admin's E-mail Address</b>	Send e-mail notification of logged events to the administrator.
<b>E-mail Log Cleared Alert</b> Off* On	Send e-mail notification to the administrator when a log entry is deleted.
<b>E-mail Log Wrapped Alert</b> Off* On	Send e-mail notification to the administrator when the log becomes full and begins to overwrite the oldest entries.
<b>Log Full Behavior</b> Wrap Over Older Entries* E-mail Log Then Delete All Entries	Resolve log storage issues when the log fills its allotted memory.
<b>E-mail % Full Alert</b> Off* On	Send e-mail notification to the administrator when the log fills its allotted memory.
<b>% Full Alert Level</b> 1–99 (90%*)	
<b>E-mail Log Exported Alert</b> Off* On	Send e-mail notification to the administrator when a log is exported.
<b>E-mail Log Settings Changed Alert</b> Off* On	Send e-mail notification to the administrator when Enable Audit is set.
<b>Log Line Endings</b> LF (\n)* CR (\r) CRLF (\r\n)	Specify how the log file terminates the end of each line.
<b>Note:</b> An asterisk (*) next to a value indicates the factory default setting.	

Menu item	Description
<b>Digitally Sign Exports</b> Off* On	Add a digital signature to each exported log file.
<b>Clear Log</b> Start	Delete all audit logs.
<b>Export Log</b> Syslog (RFC 5424) Syslog (RFC 3164) CSV	Export a security log to a flash drive.
<b>Note:</b> An asterisk (*) next to a value indicates the factory default setting.	

## Login Restrictions

Menu item	Description
<b>Login failures</b> 1–10 (3*)	Specify the number of failed login attempts before the user gets locked out.
<b>Failure time frame</b> 1–60 minutes (5*)	Specify the time frame between failed login attempts before the user gets locked out.
<b>Lockout time</b> 1–60 minutes (5*)	Specify the lockout duration.
<b>Web Login Timeout</b> 1–120 minutes (10*)	Specify the delay for a remote login before the user is logged off automatically.
<b>Note:</b> An asterisk (*) next to a value indicates the factory default setting.	

## Confidential Print Setup

Menu item	Description
<b>Max Invalid PIN</b> 2–10	<p>Set the number of times an invalid PIN can be entered.</p> <p><b>Notes:</b></p> <ul style="list-style-type: none"> <li>• A value of zero turns off this setting.</li> <li>• When the limit is reached, the print jobs for that user name and PIN are deleted.</li> <li>• This menu item appears only when a hard disk is installed.</li> </ul>
<b>Note:</b> An asterisk (*) next to a value indicates the factory default setting.	



Menu item	Description
<b>Confidential Job Expiration</b> Off* 1 Hour 4 Hours 24 Hours 1 Week	Set the expiration time for confidential print jobs.  <b>Notes:</b> <ul style="list-style-type: none"> <li>• If this menu item is changed while confidential print jobs reside in the printer memory or hard disk, then the expiration time for those print jobs does not change to the new default value.</li> <li>• If the printer is turned off, then all confidential jobs held in the printer memory are deleted.</li> </ul>
<b>Repeat Job Expiration</b> Off* 1 Hour 4 Hours 24 Hours 1 Week	Set the expiration time for a print job that you want to repeat.
<b>Verify Job Expiration</b> Off* 1 Hour 4 Hours 24 Hours 1 Week	Set the expiration time that the printer prints a copy for the user to examine its quality, before printing the remaining copies.
<b>Reserve Job Expiration</b> Off* 1 Hour 4 Hours 24 Hours 1 Week	Set the expiration time that the printer stores print jobs for printing later.
<b>Require All Jobs to be Held</b> Off* On	Set the printer to hold all print jobs.
<b>Keep duplicate documents</b> Off* On	Set the printer to print other documents with the same file name without overwriting any of the print jobs.
<b>Note:</b> An asterisk (*) next to a value indicates the factory default setting.	

## Disk Encryption

**Note:** This menu appears only when a printer hard disk is installed.

Menu item	Description
<b>Status</b> Enabled Disabled	Determine whether Disk Encryption is enabled.

Menu item	Description
<b>Start encryption</b>	Prevent the loss of sensitive data in case the printer or its hard disk is stolen. <b>Note:</b> Enabling disk encryption erases all contents in the hard disk. If necessary, back up important data from the printer before starting the encryption.

### Erase Temporary Data Files

Menu item	Description
<b>Stored in onboard memory</b> Off* On	Delete all files stored on the printer memory.
<b>Stored on hard disk</b> 1 Pass Erase* 3 Pass Erase 7 Pass Erase	Delete all files stored on the printer hard disk.
<b>Note:</b> An asterisk (*) next to a value indicates the factory default setting.	

### Solutions LDAP Settings

Use	To
<b>Follow LDAP Referrals</b> Off* On	Search the different servers in the domain for the logged-in user account.
<b>LDAP Certificate Verification</b> No* Yes	Enable verification of LDAP certificates.

### Mobile Services Management

Use	To
<b>AirPrint</b> Print Scan Fax	Enable functions in the AirPrint software feature.

### Miscellaneous

Menu item	Description
<b>Protected Features</b> Show Hide*	Show secured applications or functions on the home screen. <b>Note:</b> This menu item appears only in some printer models.
<b>Note:</b> An asterisk (*) next to a value indicates the factory default setting.	

Menu item	Description
<b>Print Permission</b> Off* On	Allow users to print.
<b>Default Print Permission Login</b>	Set the login credentials that allow users to print. <b>Note:</b> This menu item appears only in some printer models.
<b>Security Reset Jumper</b> Enable "Guest" access* No Effect	Specify the effect of using the security reset jumper. <b>Notes:</b> <ul style="list-style-type: none"> <li>• The jumper is located beside a lock icon on the controller board.</li> <li>• Enable "Guest" access provides guests with full access control.</li> <li>• No Effect means that the reset has no effect on the printer security configuration.</li> </ul>
<b>Minimum Password Length</b> 0–32 (0*)	Specify the minimum characters allowed for a password.
<b>Show Log Out Confirmation</b> Off On*	Show or hide the logout confirmation prompt.
<b>Note:</b> An asterisk (*) next to a value indicates the factory default setting.	

## Reports

### Menu Settings Page

Menu item	Description
<b>Menu Settings Page</b>	Print a report that contains the printer menus.

### Device

Menu item	Description
<b>Device Information</b>	Print a report that contains information about the printer.
<b>Device Statistics</b>	Print a report about printer usage and supply status.
<b>Profile List</b>	Print a list of profiles that are stored in the printer.
<b>Asset Report</b>	Print a report that contains the printer serial number and model name.

## Print

Menu item	Description
<b>Print Fonts</b> PCL Fonts PS Fonts	Print a list of supported fonts.

## Shortcuts

Menu item	Description
<b>All Shortcuts</b>	Print a report that lists the shortcuts that are stored in the printer.
<b>Fax Shortcuts</b>	
<b>Copy Shortcuts</b>	
<b>E-mail Shortcuts</b>	
<b>FTP Shortcuts</b>	
<b>Network Folder Shortcuts</b>	

## Fax

Menu item	Description
<b>Fax Job Log</b>	Print a report about the last 200 completed fax jobs. <b>Note:</b> This menu item appears only when Enable Job Log is set to On.
<b>Fax Call Log</b>	Print a report about the last 100 attempted, received, and blocked calls. <b>Note:</b> This menu item appears only when Enable Job Log is set to On.

## Network

Menu item	Description
<b>Network Setup Page</b>	Print a page that shows the configured network and wireless settings on the printer. <b>Note:</b> This menu item appears only in network printers or printers connected to print servers.

## Help

Menu item	Description
Print All Guides	Prints all the guides
Connection Guide	Provides information about connecting the printer locally (USB) or to a network
Copy Guide	Provides information about making copies and configuring the settings
E-mail Guide	Provides information about sending e-mails and configuring the settings

Menu item	Description
Fax Guide	Provides information about sending faxes and configuring the settings
FTP Guide	Provides information about scanning documents and configuring the settings
Information Guide	Provides more information sources about the printer
Media Guide	Provides information about loading paper and specialty media
Mono Quality Guide	Provides information about mono print quality settings
Moving Guide	Provides information about moving, locating, or shipping the printer
Print Quality Guide	Provides information about solving print quality issues
Supplies Guide	Provides information about ordering supplies

## Troubleshooting

### Troubleshooting

Menu item	Description
<b>Print Quality Test Pages</b>	Print sample pages to identify and correct print quality defects.
<b>Cleaning the Scanner</b>	Print instructions on how to clean the scanner.

# Securing the printer

## Locating the security slot

The printer is equipped with a security lock feature. Attach a security lock compatible with most laptop computers in the location shown to secure the printer in place.

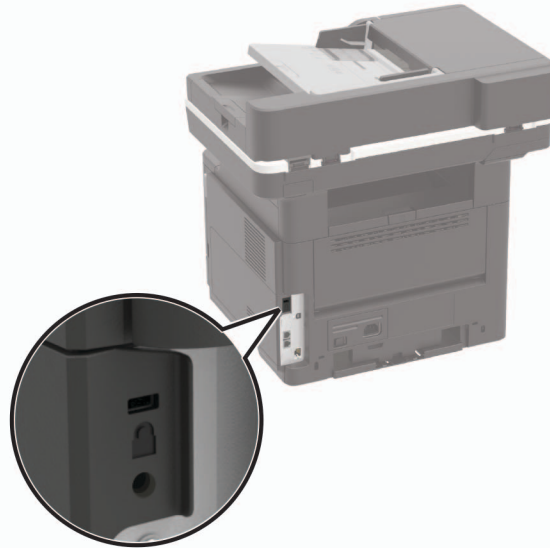

## Erasing printer memory

To erase volatile memory or buffered data in your printer, turn off the printer.

To erase non-volatile memory or individual settings, device and network settings, security settings, and embedded solutions, do the following:

- 1 From the home screen, touch **Settings** > **Device** > **Maintenance** > **Out of Service Erase**.
- 2 Select the **Sanitize all information on nonvolatile memory** check box, and then touch **ERASE**.
- 3 Follow the instructions on the display.

## Erasing printer hard disk memory

- 1 From the home screen, touch **Settings** > **Device** > **Maintenance** > **Out of Service Erase**.
- 2 Select the **Sanitize all information on hard disk** check box, and then touch **ERASE**.
- 3 Follow the instructions on the display.

**Note:** This process can take from several minutes to more than an hour, making the printer unavailable for other tasks.

## Configuring printer hard disk encryption

1 From the home screen, touch **Settings > Security > Disk Encryption > Start Encryption**.

**Note:** Enabling disk encryption erases the contents of the hard disk. If necessary, back up important data from the printer before starting the encryption.

2 Follow the instructions on the display.

**Notes:**

- Do not turn off the printer during the encryption process. Loss of data can occur.
- Disk encryption can take from several minutes to more than an hour, making the printer unavailable for other tasks.
- After encryption, the printer returns to the home screen.

## Restoring factory default settings

From the home screen, touch **Settings > Device > Restore Factory Defaults > Restore Settings > Restore all settings > RESTORE > Start**.

For more information, see [“Erasing printer memory” on page 130](#).

## Statement of Volatility

Your printer contains various types of memory that can store device and network settings, and user data.

Type of memory	Description
Volatile memory	Your printer uses standard <i>random access memory</i> (RAM) to temporarily buffer user data during simple print jobs.
Non-volatile memory	Your printer may use two forms of non-volatile memory: EEPROM and NAND (flash memory). Both types are used to store the operating system, device settings, network information and bookmark settings, and embedded solutions.
Hard disk memory	Some printers have a hard disk drive installed. The printer hard disk is designed for printer-specific functionality. This lets the printer retain buffered user data from complex print jobs, as well as form data, and font data.

Erase the content of any installed printer memory in the following circumstances:

- The printer is being decommissioned.
- The printer hard disk is being replaced.
- The printer is being moved to a different department or location.
- The printer is being serviced by someone from outside your organization.
- The printer is being removed from your premises for service.
- The printer is being sold to another organization.

## Disposing of a printer hard disk

**Note:** Some printer models may not have a printer hard disk installed.

In high-security environments, it may be necessary to take additional steps to make sure that confidential data stored in the printer hard disk cannot be accessed when the printer—or its hard disk—is removed from your premises.

- **Degaussing**—Flushes the hard disk with a magnetic field that erases stored data
- **Crushing**—Physically compresses the hard disk to break component parts and render them unreadable
- **Milling**—Physically shreds the hard disk into small metal bits

**Note:** Most data can be erased electronically, but the only way to guarantee that all data are completely erased is to physically destroy each hard disk where data is stored.



# Maintaining the printer

**Warning—Potential Damage:** Failure to maintain optimum printer performance, or to replace parts and supplies, may cause damage to your printer.

## Networking

### Preparing to set up the printer on an Ethernet network

Before connecting your printer to an Ethernet network, make sure to have the following information:

- A valid, unique IP address for the printer to use on the network
- The network gateway
- The network mask
- A nickname for the printer (optional)

**Note:** A printer nickname makes it easier to identify your printer on the network.

You need an Ethernet cable to connect the printer to the network and an available port where the printer can physically connect to the network. Use a new network cable when possible to avoid potential problems caused by a damaged cable.

### Preparing to set up the printer on a wireless network

#### Notes:

- Make sure that your wireless network adapter is installed in your printer and working properly. For more information, see the instruction sheet that came with the adapter.
- The wireless network adapter is standard in some printer models.
- Make sure that your access point (wireless router) is turned on and working properly.

Make sure to have the following information:

- **SSID**—The SSID is also referred to as the network name.
- **Wireless Mode (or Network Mode)**—The mode is either infrastructure or ad hoc.
- **Channel (for ad hoc networks)**—The channel defaults to automatic for infrastructure networks.

Some ad hoc networks also require the automatic setting. Check with your administrator if you are not sure which channel to select.

- **Security Method**—Select one of the following:

- WEP key

If your network uses more than one WEP key, then enter up to four keys. Select the key currently in use on the network by selecting the default WEP transmit key.

- WPA or WPA2 preshared key or passphrase

WPA includes encryption as an extra layer of security. Set the same encryption type on the router and on the printer, for the printer to communicate with the network.

- 802.1X—RADIUS

If you are installing the printer on an 802.1X network, then you need the following:

- Authentication type
  - Inner authentication type
  - 802.1X user name and password
  - Certificates
- No security

If your wireless network does not use any type of security, then you do not have any security information.

**Note:** Do not use an unsecured wireless network.

#### Notes:

- If you do not know the SSID of the network that your computer is connected to, then launch the wireless utility of the computer network adapter, and then look for the network name. If you cannot find the SSID or the security information for your network, then see the documentation that came with the access point, or contact your administrator.
- To find the WPA/WPA2 preshared key or passphrase for the wireless network, see the documentation that came with the access point, see the Embedded Web Server associated with the access point, or contact your administrator.

## Connecting the printer to a wireless network using Wi-Fi Protected Setup (WPS)

Before you begin, make sure that:

- The access point (wireless router) is WPS-certified or WPS-compatible. For more information, see the documentation that came with your access point.
- A wireless network adapter is installed in your printer. For more information, see the instructions that came with the adapter.

### Using the Push Button method

- 1 From the control panel, navigate to:  
**Settings > Network/Ports > Wireless > Wi-Fi Protected Setup > Start Push Button Method**
- 2 Follow the instructions on the display.

### Using the personal identification number (PIN) method

- 1 From the control panel, navigate to:  
**Settings > Network/Ports > Wireless > Wi-Fi Protected Setup > Start PIN Method**
- 2 Copy the eight-digit WPS PIN.
- 3 Open a Web browser, and then type the IP address of your access point in the address field.

#### Notes:

- View the printer IP address on the printer home screen. The IP address appears as four sets of numbers separated by periods, such as 123.123.123.123.
- If you are using a proxy server, then temporarily disable it to load the Web page correctly.

- 4 Access the WPS settings. For more information, see the documentation that came with your access point.
- 5 Enter the eight-digit PIN, and then save the changes.

## Cleaning printer parts

### Cleaning the printer

 **CAUTION—SHOCK HAZARD:** To avoid the risk of electrical shock when cleaning the exterior of the printer, unplug the power cord from the electrical outlet and disconnect all cables from the printer before proceeding.

#### Notes:

- Perform this task after every few months.
- Damage to the printer caused by improper handling is not covered by the printer warranty.

- 1 Turn off the printer, and then unplug the power cord from the electrical outlet.
- 2 Remove paper from the standard bin and multipurpose feeder.
- 3 Remove any dust, lint, and pieces of paper around the printer using a soft brush or vacuum.
- 4 Wipe the outside of the printer with a damp, soft, lint-free cloth.

#### Notes:

- Do not use household cleaners or detergents, as they may damage the finish of the printer.
- Make sure that all areas of the printer are dry after cleaning.

- 5 Connect the power cord to the electrical outlet, and then turn on the printer.

 **CAUTION—POTENTIAL INJURY:** To avoid the risk of fire or electrical shock, connect the power cord to an appropriately rated and properly grounded electrical outlet that is near the product and easily accessible.

## Cleaning the scanner

- 1 Open the scanner cover.



- 2 Using a damp, soft, lint-free cloth, wipe the following areas:

- ADF glass



- ADF glass pad



- Scanner glass



- Scanner glass pad



**3** Close the scanner cover.

**4** Open the ADF cover.



**5** Using a damp, soft, lint-free cloth, wipe the following areas:

- ADF glass pad in the ADF cover

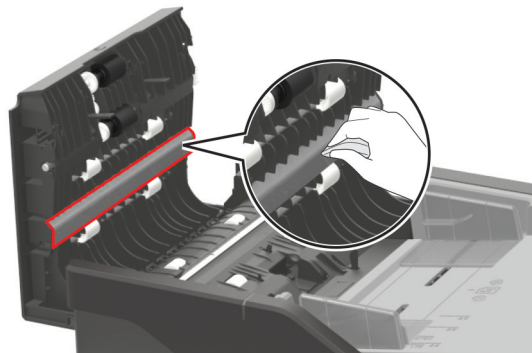

- ADF glass in the ADF cover

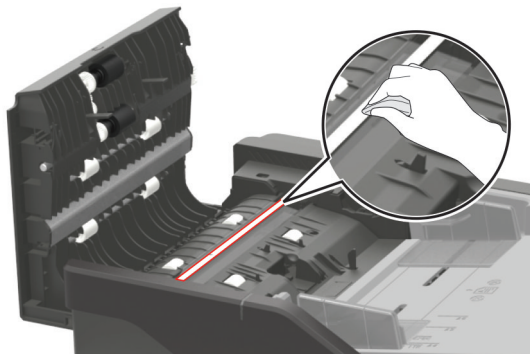

**6** Close the ADF cover.

## Ordering parts and supplies

To order supplies, contact the place where you purchased the printer.

**Note:** All life estimates for printer supplies assume printing on letter- or A4-size plain paper.

### Using genuine KONICA MINOLTA parts and supplies

Your KONICA MINOLTA printer is designed to function best with genuine KONICA MINOLTA supplies and parts. Use of third-party supplies or parts may affect the performance, reliability, or life of the printer and its imaging components. Use of third-party supplies or parts can affect warranty coverage. Damage caused by the use of third-party supplies and parts is not covered by the warranty. All life indicators are designed to function with KONICA MINOLTA supplies and parts, and may deliver unpredictable results if third-party supplies and parts are used. Imaging component usage beyond the intended life may damage your KONICA MINOLTA printer or its associated components.

### Ordering a toner cartridge

**Notes:**

- The estimated cartridge yield is based on the ISO/IEC 19752 standard.
- Extremely low print coverage for extended periods of time may negatively affect actual yield.

To order a toner cartridge, contact the place where you purchased the printer.

### Ordering an imaging unit

To order an imaging unit, contact the place where you purchased the printer.

### Checking the status of parts and supplies

- 1** From the home screen, touch **Status/Supplies**.
- 2** Select the parts or supplies that you want to check.

**Note:** You can also access this setting by touching the top section of the home screen.

## Configuring supply notifications

1 Open a web browser, and then type the printer IP address in the address field.

**Notes:**

- View the printer IP address on the printer home screen. The IP address appears as four sets of numbers separated by periods, such as 123.123.123.123.
- If you are using a proxy server, then temporarily disable it to load the web page correctly.

2 Click **Settings** > **Device** > **Notifications**.

3 From the Supplies menu, click **Custom Supply Notifications**.

4 Select a notification for each supply item.

5 Apply the changes.

## Replacing parts and supplies

### Replacing the toner cartridge

1 Open the front door.

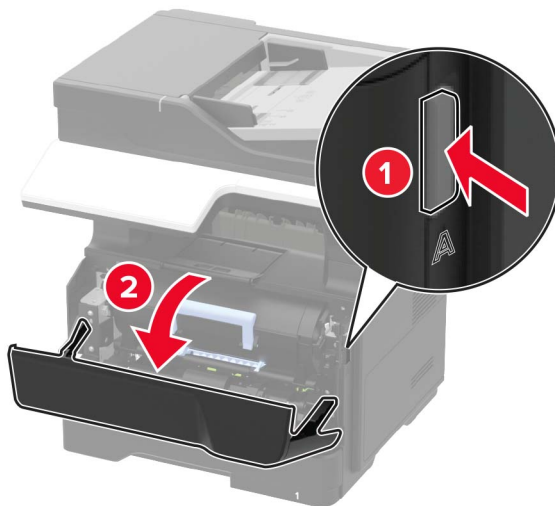

- 2 Remove the used toner cartridge.

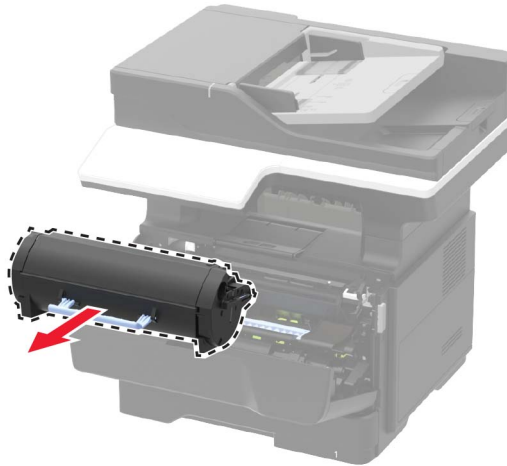

- 3 Unpack the new toner cartridge, and then shake it three times to redistribute the toner.

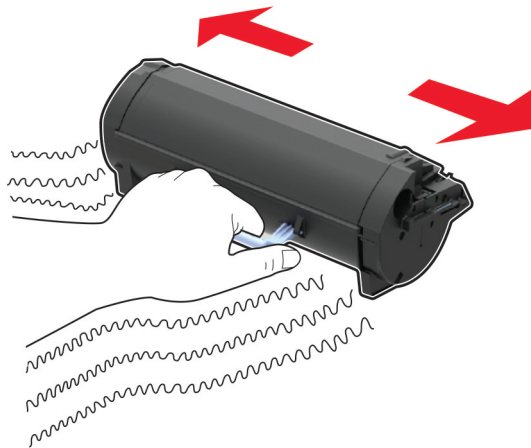

- 4 Insert the new toner cartridge.

**Note:** Use the arrows inside the printer as guides.





5 Close the front door.

**Note:** Dispose of the empty toner cartridge according to your local regulations. Do not burn the cartridge.

**CAUTION—POTENTIAL INJURY:** If you get toner in your eyes, wash it out immediately with cool water and consult a doctor.

## Replacing the imaging unit

1 Open the front door.

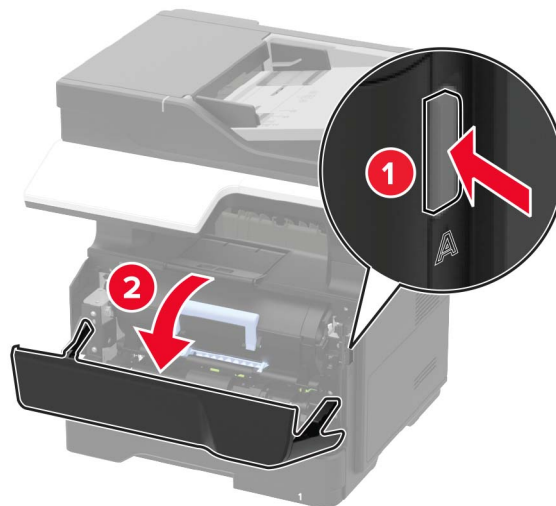

- 2 Remove the toner cartridge.

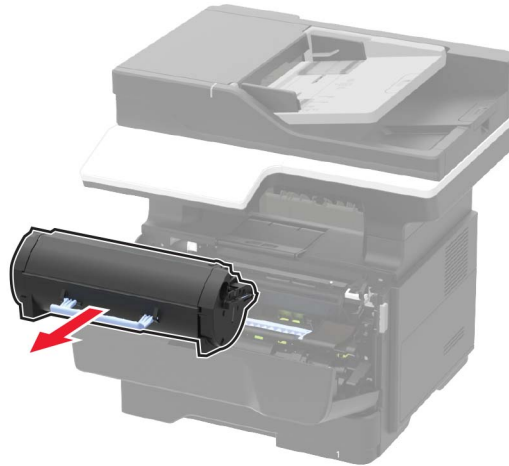

- 3 Remove the used imaging unit.

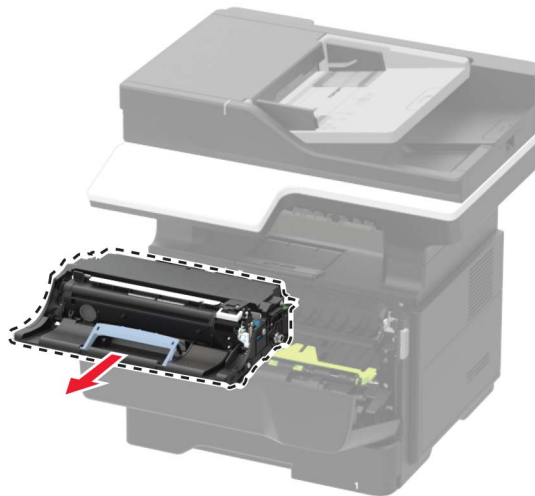

- 4 Unpack the new imaging unit, and then shake it three times to redistribute the toner.

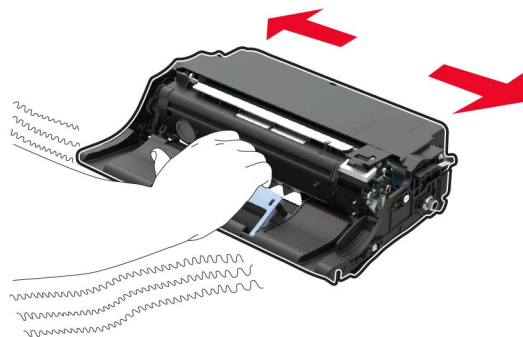

**Warning—Potential Damage:** Do not expose the imaging unit to direct light for more than 10 minutes. Extended exposure to light may cause print quality problems.

**Warning—Potential Damage:** Do not touch the photoconductor drum. Doing so may affect the quality of future print jobs.



**5** Insert the new imaging unit.

**Note:** Use the arrows inside the printer as guides.



**6** Insert the toner cartridge.

**Note:** Use the arrows inside the printer as guides.



**7** Close the front door.

**Note:** Dispose of the used imaging unit according to your local regulations. Do not burn the imaging unit.

## Replacing the pick tires

- 1** Turn off the printer.
- 2** Unplug the power cord from the electrical outlet, and then from the printer.
- 3** Remove the tray.

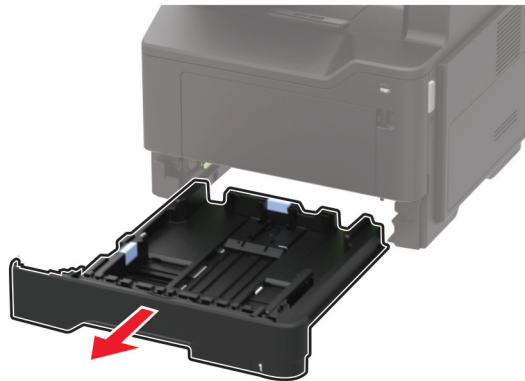

4 Remove the used pick tires one after the other.

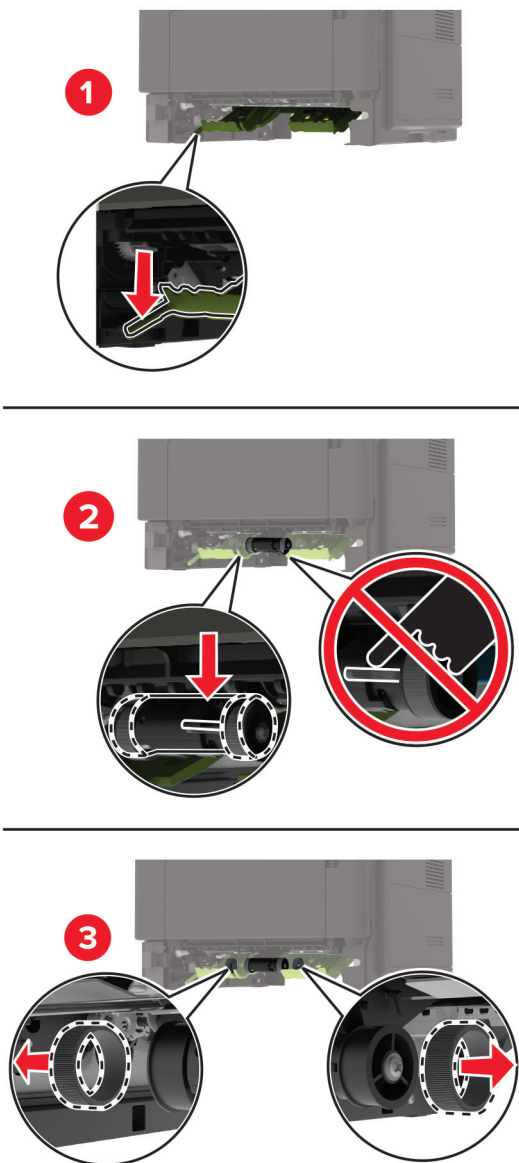

5 Unpack the new pick tires.

- 6 Insert the new pick tires.

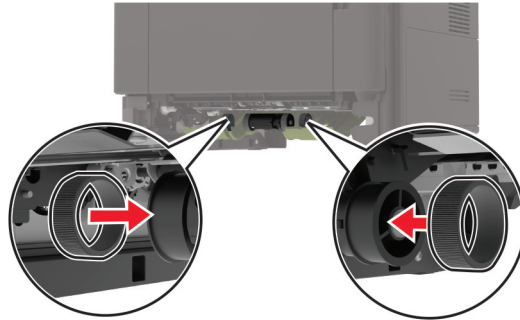

- 7 Insert the tray.
- 8 Connect the power cord to the printer, and then to the electrical outlet.

**⚠ CAUTION—POTENTIAL INJURY:** To avoid the risk of fire or electrical shock, connect the power cord to an appropriately rated and properly grounded electrical outlet that is near the product and easily accessible.

- 9 Turn on the printer.

## Replacing the pick roller assembly

- 1 Turn off the printer.
- 2 Unplug the power cord from the electrical outlet, and then from the printer.
- 3 Remove the optional tray.

**⚠ CAUTION—POTENTIAL INJURY:** If the printer weight is greater than 18 kg (40 lb), then it requires two or more trained personnel to lift it safely.



**4** Remove the tray insert, and then flip the tray base.

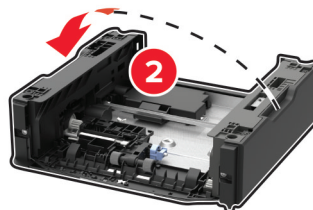
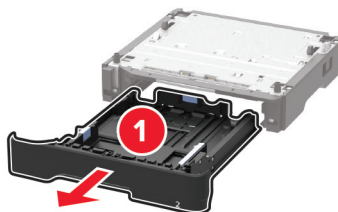

**5** Remove the used pick roller assembly.

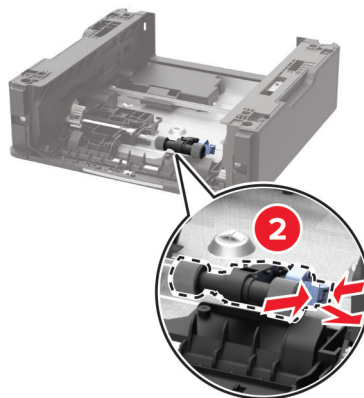
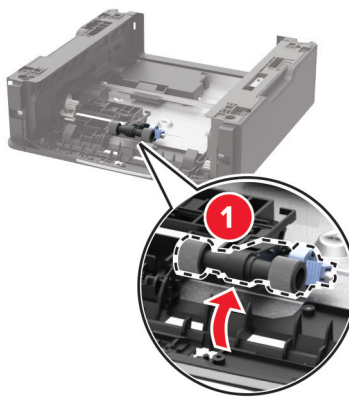

**6** Unpack the new pick roller assembly.



**7** Insert the new pick roller assembly.

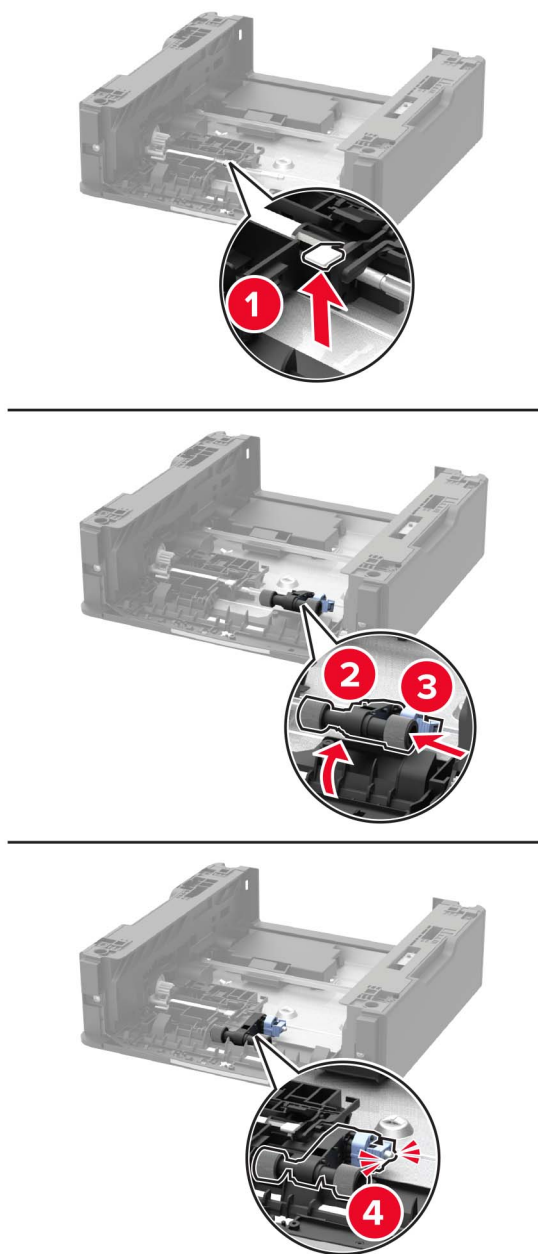

**8** Flip the tray base, and then insert the tray insert.

- 9 Align the printer with the optional tray, and then lower the printer until it *clicks* into place.



- 10 Connect the power cord to the printer, and then to the electrical outlet.

**CAUTION—POTENTIAL INJURY:** To avoid the risk of fire or electrical shock, connect the power cord to an appropriately rated and properly grounded electrical outlet that is near the product and easily accessible.

- 11 Turn on the printer.

## Moving the printer

### Moving the printer to another location

**CAUTION—POTENTIAL INJURY:** If the printer weight is greater than 18 kg (40 lb), then it requires two or more trained personnel to lift it safely.

**CAUTION—POTENTIAL INJURY:** To avoid the risk of fire or electrical shock, use only the power cord provided with this product or the manufacturer's authorized replacement.

**CAUTION—POTENTIAL INJURY:** When moving the printer, follow these guidelines to avoid personal injury or printer damage:

- Make sure that all doors and trays are closed.
- Turn off the printer, and then unplug the power cord from the electrical outlet.
- Disconnect all cords and cables from the printer.
- If the printer has separate floor-standing optional trays or output options attached to it, then disconnect them before moving the printer.
- If the printer has a caster base, then carefully roll it to the new location. Use caution when passing over thresholds and breaks in flooring.
- If the printer does not have a caster base but is configured with optional trays or output options, then remove the output options and lift the printer off the trays. Do not try to lift the printer and any options at the same time.

- Always use the handholds on the printer to lift it.
- Any cart used to move the printer must have a surface able to support the full footprint of the printer.
- Any cart used to move the hardware options must have a surface able to support the dimensions of the options.
- Keep the printer in an upright position.
- Avoid severe jarring movements.
- Make sure that your fingers are not under the printer when you set it down.
- Make sure that there is adequate clearance around the printer.

**Note:** Damage to the printer caused by improper moving is not covered by the printer warranty.

## Shipping the printer

When shipping the printer, use the original packaging or contact the place where you purchased the printer.

## Saving energy and paper

### Configuring the power save mode settings

#### Eco-Mode

- 1 From the home screen, touch **Settings > Device > Power Management > Eco-Mode**.
- 2 Select a setting.

#### Sleep mode

- 1 From the home screen, touch **Settings > Device > Power Management > Timeouts > Sleep Mode**.
- 2 Specify the amount of time that the printer stays idle before it enters Sleep mode.

#### Hibernate mode

- 1 From the home screen, touch **Settings > Device > Power Management > Timeouts > Hibernate Timeout**.
- 2 Select the amount of time that the printer stays idle before it enters Hibernate mode.

#### Notes:

- For Hibernate Timeout to work, set Hibernate Timeout on Connection to Hibernate.
- The Embedded Web Server is disabled when the printer is in Hibernate mode.

## Adjusting the brightness of the printer display

- 1 From the home screen, touch **Settings > Device > Preferences > Screen Brightness**.
- 2 Adjust the setting.

## Conserving supplies

- Print on both sides of the paper.

**Note:** Two-sided printing is the default setting in the print driver.

- Print multiple pages on a single sheet of paper.
- Use the preview feature to see how the document looks like before printing it.
- Print one copy of the document to check its content and format for accuracy.

# Clearing jams

## Avoiding jams

### Load paper properly

- Make sure that the paper lies flat in the tray.

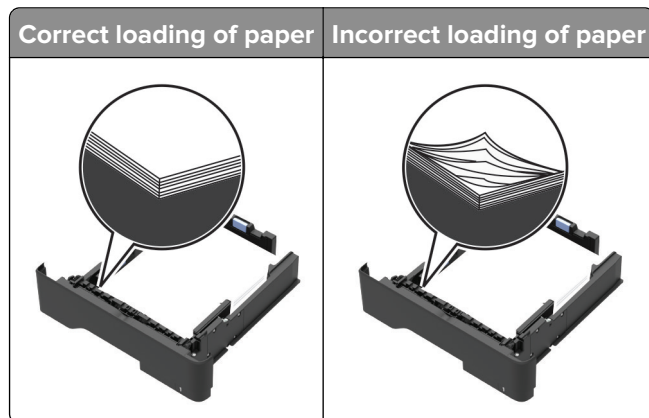

- Do not load or remove a tray while the printer is printing.
- Do not load too much paper. Make sure that the stack height is below the maximum paper fill indicator.
- Do not slide paper into the tray. Load paper as shown in the illustration.



- Make sure that the paper guides are positioned correctly and are not pressing tightly against the paper or envelopes.
- Push the tray firmly into the printer after loading paper.

### Use recommended paper

- Use only recommended paper or specialty media.
- Do not load paper that is wrinkled, creased, damp, bent, or curled.

- Flex, fan, and align the paper edges before loading.

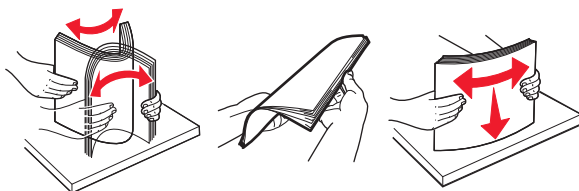

- Do not use paper that has been cut or trimmed by hand.
- Do not mix paper sizes, weights, or types in the same tray.
- Make sure that the paper size and type are set correctly on the computer or printer control panel.
- Store paper according to manufacturer recommendations.

## Identifying jam locations

### Notes:

- When Jam Assist is set to On, the printer automatically flushes blank pages or partially printed pages with after a jammed page is cleared. Check your printed output for blank pages.
- When Jam Recovery is set to On or Auto, the printer reprints jammed pages.

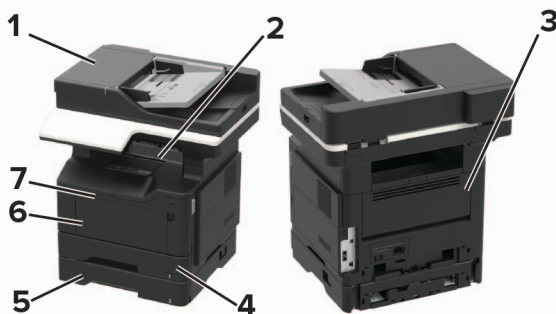

	Jam location
1	Automatic document feeder
2	Standard bin
3	Rear door
4	Duplex unit
5	Tray
6	Multipurpose feeder
7	Front door

## Paper jam in the front door

- 1 Remove the tray.



- 2 Open the front door.

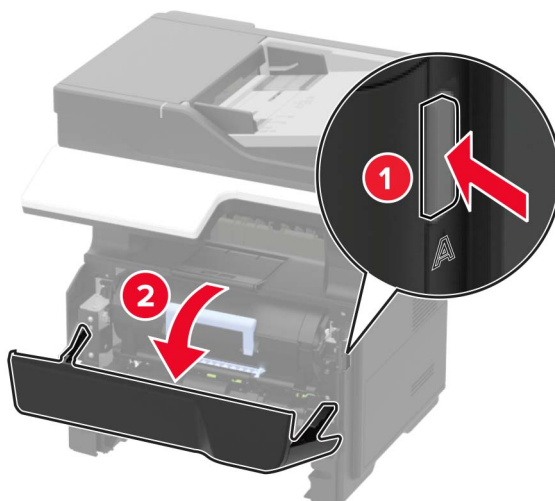

- 3 Remove the toner cartridge.

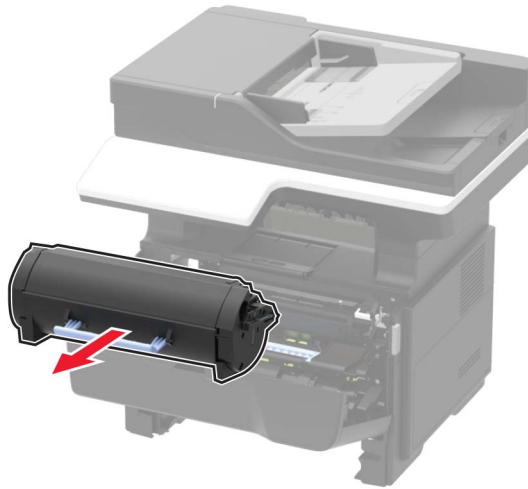

- 4 Remove the imaging unit.

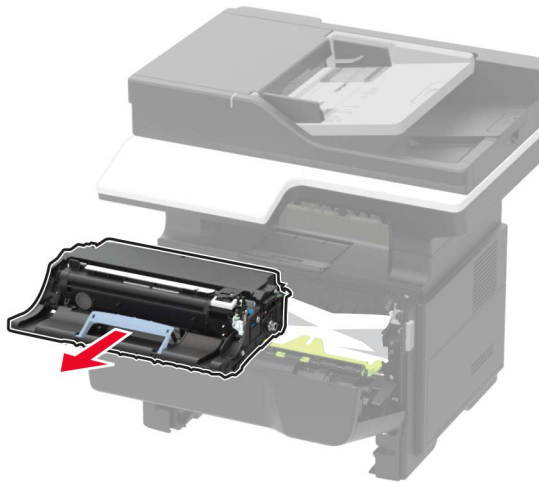

**Warning—Potential Damage:** Do not expose the imaging unit to direct light for more than 10 minutes. Extended exposure to light may cause print quality problems.

**Warning—Potential Damage:** Do not touch the photoconductor drum. Doing so may affect the quality of future print jobs.





**5** Remove the jammed paper.

**Note:** Make sure that all paper fragments are removed.

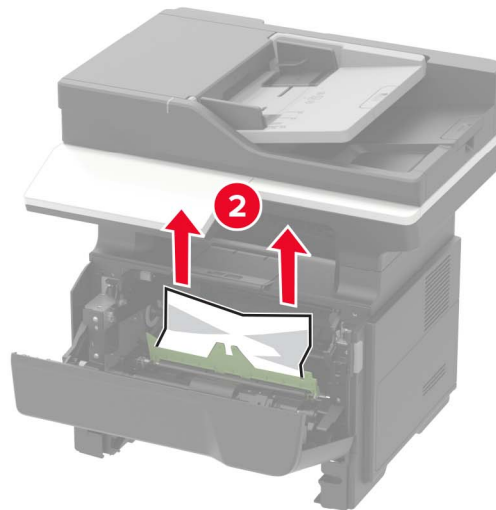
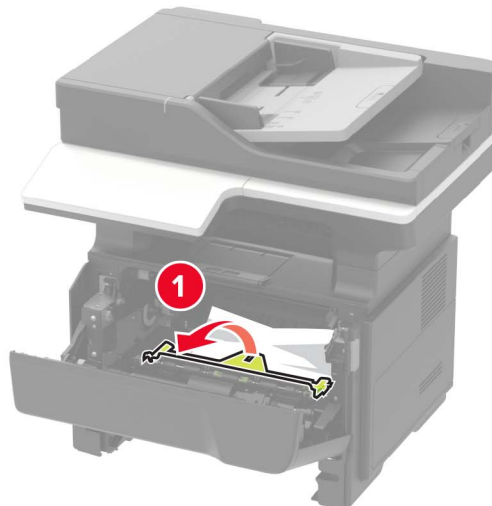

**6** Insert the imaging unit.

**Note:** Use the arrows inside the printer as guides.

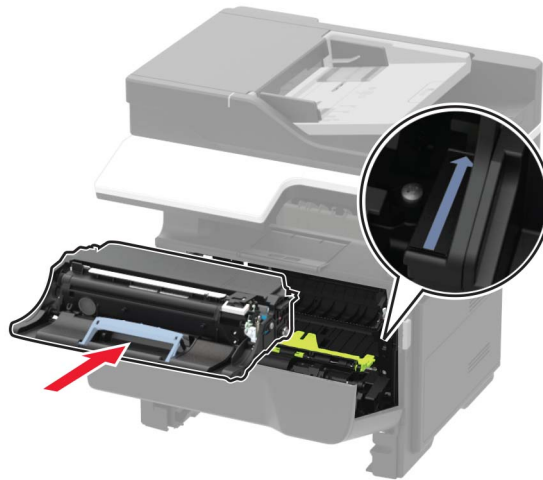

7 Insert the toner cartridge.

**Note:** Use the arrows inside the printer as guides.



8 Close the front door.

9 Insert the tray.

## Paper jam in the rear door

1 Open the rear door.

 **CAUTION—HOT SURFACE:** The inside of the printer might be hot. To reduce the risk of injury from a hot component, allow the surface to cool before touching it.

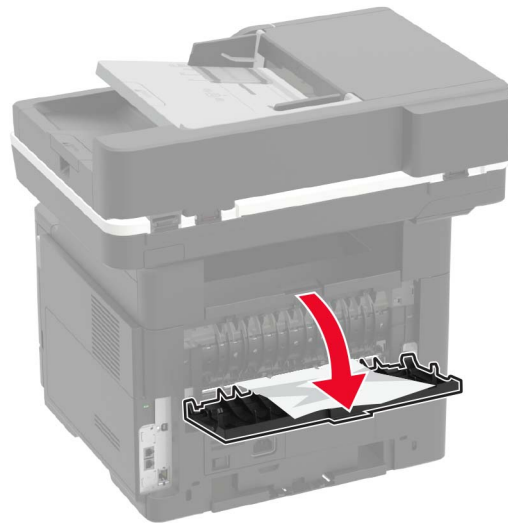

**2** Remove the jammed paper.

**Note:** Make sure that all paper fragments are removed.

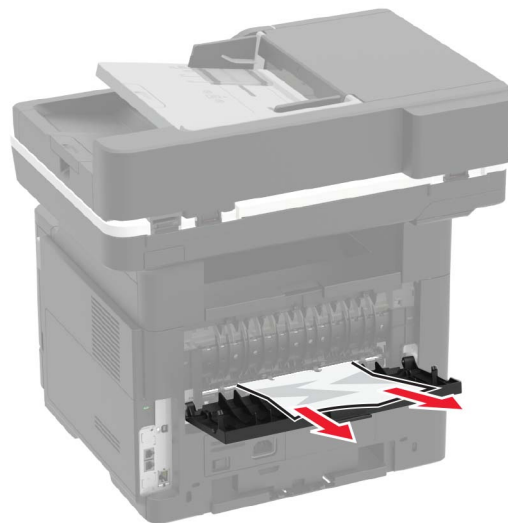

**3** Close the rear door.

## Paper jam in the standard bin

Remove the jammed paper.

**Note:** Make sure that all paper fragments are removed.

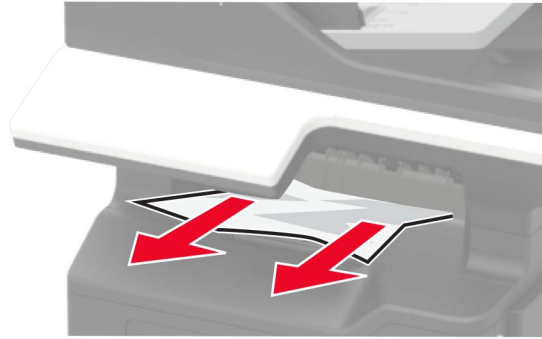

## Paper jam in the duplex unit

1 Remove the tray.



2 Remove the jammed paper.

**Note:** Make sure that all paper fragments are removed.

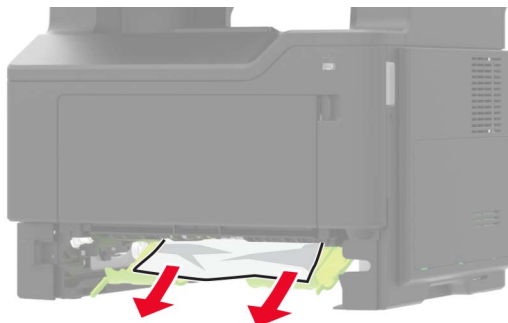

3 Insert the tray.

## Paper jam in trays

- 1 Remove the tray.



- 2 Remove the jammed paper.

**Note:** Make sure that all paper fragments are removed.

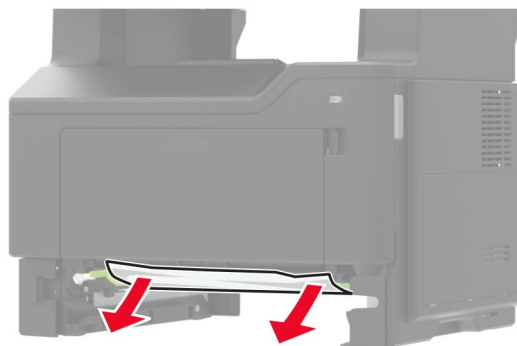

- 3 Insert the tray.

## Paper jam in the multipurpose feeder

- 1 Remove paper from the multipurpose feeder.
- 2 Remove the jammed paper.

**Note:** Make sure that all paper fragments are removed.



**3** Flex, fan, and align the paper edges before loading.

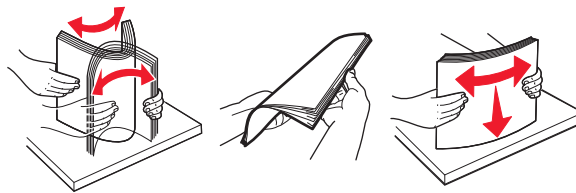

**4** Reload paper, and then adjust the paper guide.



## Paper jam in the automatic document feeder

- 1** Remove all original documents from the ADF tray.
- 2** Open the ADF cover.

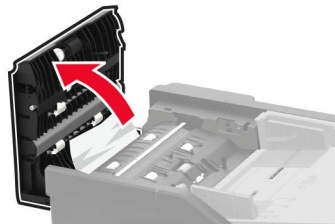

**3** Remove the jammed paper.

**Note:** Make sure that all paper fragments are removed.

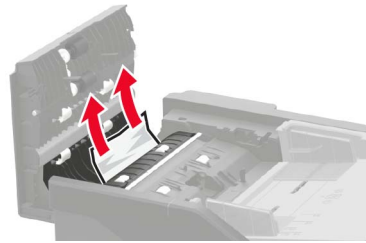

**4** Close the ADF cover.

# Troubleshooting

## Network connection problems

### Cannot open Embedded Web Server

Action	Yes	No
<p><b>Step 1</b></p> <p>Check if you are using a supported browser:</p> <ul style="list-style-type: none"> <li>• Internet Explorer® version 9 or later</li> <li>• Safari version 8.0.3 or later</li> <li>• Google Chrome™</li> <li>• Mozilla Firefox</li> </ul> <p>Is your browser supported?</p>	Go to step 2.	Install a supported browser.
<p><b>Step 2</b></p> <p>Make sure that the printer IP address is correct.</p> <p>View the printer IP address:</p> <ul style="list-style-type: none"> <li>• From the home screen</li> <li>• From the TCP/IP section in the Network/Ports menu</li> <li>• By printing a network setup page or menu settings page, and then finding the TCP/IP section</li> </ul> <p><b>Note:</b> An IP address appears as four sets of numbers separated by periods, such as 123.123.123.123.</p> <p>Is the printer IP address correct?</p>	Go to step 3.	Type the correct printer IP address in the address field.
<p><b>Step 3</b></p> <p>Check if the printer is on.</p> <p>Is the printer on?</p>	Go to step 4.	Turn on the printer.
<p><b>Step 4</b></p> <p>Check if the network connection is working.</p> <p>Is the network connection working?</p>	Go to step 5.	Contact your administrator.
<p><b>Step 5</b></p> <p>Make sure that the cable connections to the printer and print server are secure.</p> <p>For more information, see the setup documentation that came with the printer.</p> <p>Are the cable connections secure?</p>	Go to step 6.	Secure the cable connections.



Action	Yes	No
<p><b>Step 6</b> Check if the web proxy servers are disabled.</p> <p>Are the web proxy servers disabled?</p>	Go to step 7.	Contact your administrator.
<p><b>Step 7</b> Access the Embedded Web Server.</p> <p>Did the Embedded Web Server open?</p>	The problem is solved.	Contact <a href="#">customer support</a> .

### Unable to read flash drive

Action	Yes	No
<p><b>Step 1</b> Check if the flash drive is inserted into the front USB port.</p> <p><b>Note:</b> The flash drive does not work when it is inserted into the rear USB port.</p> <p>Is the flash drive inserted into the correct port?</p>	Go to step 2.	Insert the flash drive into the correct port.
<p><b>Step 2</b> Check if the flash drive is supported. For more information, see <a href="#">“Supported flash drives and file types” on page 28</a>.</p> <p>Is the flash drive supported?</p>	Go to step 3.	Insert a supported flash drive.
<p><b>Step 3</b></p> <p><b>a</b> Check if the USB port is enabled. For more information, see <a href="#">“Enabling the USB port” on page 165</a>.</p> <p><b>b</b> Remove, and then insert the flash drive.</p> <p>Does the printer recognize the flash drive?</p>	The problem is solved.	Contact <a href="#">customer support</a> .

### Enabling the USB port

From the home screen, touch **Settings > Network/Ports > USB > Enable USB Port**.

### Checking the printer connectivity

- 1 From the home screen, touch **Settings > Reports > Network > Network Setup Page**.
- 2 Check the first section of the network setup page, and confirm that the status is connected.  
If the status is not connected, then the LAN drop may be inactive, or the network cable may be malfunctioning. Contact your administrator for assistance.

# Internal option problems

## Cannot detect internal option

Action	Yes	No
<p><b>Step 1</b> Turn off the printer, wait for about 10 seconds, and then turn it back on.</p> <p>Does the internal option operate correctly?</p>	The problem is solved.	Go to step 2.
<p><b>Step 2</b> Print a menu settings page, and then check if the internal option appears in the Installed Features list.</p> <p>Is the internal option listed in the menu settings page?</p>	Go to step 4.	Go to step 3.
<p><b>Step 3</b> Check if the internal option is properly installed in the controller board.</p> <ul style="list-style-type: none"> <li><b>a</b> Turn off the printer, and then unplug the power cord from the electrical outlet.</li> <li><b>b</b> Make sure that the internal option is installed in the appropriate connector in the controller board.</li> <li><b>c</b> Connect the power cord to the electrical outlet, and then turn on the printer.</li> </ul> <p> <b>CAUTION—POTENTIAL INJURY:</b> To avoid the risk of fire or electrical shock, connect the power cord to an appropriately rated and properly grounded electrical outlet that is near the product and easily accessible.</p> <p>Does the internal option operate correctly?</p>	The problem is solved.	Go to step 4.
<p><b>Step 4</b></p> <ul style="list-style-type: none"> <li><b>a</b> Check if the internal option is available in the print driver. <b>Note:</b> If necessary, manually add the internal option in the print driver to make it available for print jobs. For more information, see <a href="#">“Adding available options in the print driver” on page 213.</a></li> <li><b>b</b> Resend the print job.</li> </ul> <p>Does the internal option operate correctly?</p>	The problem is solved.	Contact <a href="#">customer support</a> .

## Paper feed problems

### Envelope seals when printing

Action	Yes	No
<p><b>1</b> Use envelopes that have been stored in a dry environment.</p> <p><b>Note:</b> Printing on envelopes with high moisture content can seal the flaps.</p> <p><b>2</b> Resend the print job.</p> <p>Does the envelope seal when printing?</p>	<p>Contact <a href="#">customer support</a>.</p>	<p>The problem is solved.</p>

### Collated printing does not work

Action	Yes	No
<p><b>Step 1</b></p> <p><b>a</b> From the home screen, touch <b>Settings &gt; Print &gt; Layout &gt; Collate</b>.</p> <p><b>b</b> Set Collate to On.</p> <p><b>c</b> Print the document.</p> <p>Are the pages collated correctly?</p>	<p>The problem is solved.</p>	<p>Go to step 2.</p>
<p><b>Step 2</b></p> <p><b>a</b> From the document that you are trying to print, open the Print dialog, and then select Collate.</p> <p><b>b</b> Print the document.</p> <p>Are the pages collated correctly?</p>	<p>The problem is solved.</p>	<p>Go to step 3.</p>
<p><b>Step 3</b></p> <p><b>a</b> Reduce the number of pages to print.</p> <p><b>b</b> Print the document.</p> <p>Are the pages collated correctly?</p>	<p>The problem is solved.</p>	<p>Contact <a href="#">customer support</a>.</p>

### Tray linking does not work

Action	Yes	No
<p><b>Step 1</b></p> <p><b>a</b> Check if the trays have the same paper size and type.</p> <p><b>b</b> Check if the paper guides are positioned correctly.</p> <p><b>c</b> Print the document.</p> <p>Do the trays link correctly?</p>	<p>The problem is solved.</p>	<p>Go to step 2.</p>

Action	Yes	No
<p><b>Step 2</b></p> <p><b>a</b> From the home screen, touch <b>Settings &gt; Paper &gt; Tray Configuration &gt; Paper Size/Type</b>.</p> <p><b>b</b> Set the paper size and type to match the paper loaded in the linked trays.</p> <p><b>c</b> Print the document.</p> <p>Do the trays link correctly?</p>	<p>The problem is solved.</p>	<p>Contact <a href="#">customer support</a>.</p>

## Paper frequently jams

Action	Yes	No
<p><b>Step 1</b></p> <p><b>a</b> Pull out the tray.</p> <p><b>b</b> Check if the paper is loaded correctly.</p> <p><b>Notes:</b></p> <ul style="list-style-type: none"> <li>• Make sure that the paper guides are positioned correctly.</li> <li>• Make sure that the stack height is below the maximum paper fill indicator.</li> <li>• Make sure to print on recommended paper size and type.</li> </ul> <p><b>c</b> Insert the tray.</p> <p><b>d</b> Print the document.</p> <p>Do paper jams still occur frequently?</p>	<p>Go to step 2.</p>	<p>The problem is solved.</p>
<p><b>Step 2</b></p> <p><b>a</b> From the Paper menu on the control panel, check if the printer is detecting the correct paper size.</p> <p><b>b</b> Resend the print job.</p> <p>Do paper jams still occur frequently?</p>	<p>Go to step 3.</p>	<p>The problem is solved.</p>
<p><b>Step 3</b></p> <p><b>a</b> Load paper from a fresh package.</p> <p><b>b</b> Print the document.</p> <p>Do paper jams still occur frequently?</p>	<p>Contact <a href="#">customer support</a>.</p>	<p>The problem is solved.</p>

## Jammed pages are not reprinted

Action	Yes	No
<p><b>a</b> From the home screen, touch <b>Settings &gt; Device &gt; Notifications &gt; Jam Content Recovery</b>.</p> <p><b>b</b> Select <b>On</b> or <b>Auto</b>.</p> <p><b>c</b> Apply the changes.</p> <p>Are the jammed pages reprinted?</p>	The problem is solved.	Contact <a href="#">customer support</a> .

## Printing problems

### Confidential and other held documents do not print

Action	Yes	No
<p><b>Step 1</b></p> <p><b>a</b> From the control panel, check if the documents appear in the Held Jobs list.</p> <p><b>Note:</b> If the documents are not listed, then print the documents using the Print and Hold options.</p> <p><b>b</b> Print the documents.</p> <p>Are the documents printed?</p>	The problem is solved.	Go to step 2.
<p><b>Step 2</b></p> <p>The print job may contain a formatting error or invalid data.</p> <ul style="list-style-type: none"> <li>Delete the print job, and then send it again.</li> <li>For PDF files, generate a new file, and then print the documents.</li> </ul> <p>Are the documents printed?</p>	The problem is solved.	Go to step 3.

Action	Yes	No
<p><b>Step 3</b></p> <p>If you are printing from the Internet, then the printer may be reading the multiple job titles as duplicates.</p> <p><b>For Windows users</b></p> <ul style="list-style-type: none"> <li><b>a</b> Open the Printing Preferences dialog.</li> <li><b>b</b> From the Print and Hold section, select <b>Keep duplicate documents</b>.</li> <li><b>c</b> Enter a PIN.</li> <li><b>d</b> Resend the print job.</li> </ul> <p><b>For Macintosh users</b></p> <ul style="list-style-type: none"> <li><b>a</b> Save and name each job differently.</li> <li><b>b</b> Send the job individually.</li> </ul> <p>Are the documents printed?</p>	The problem is solved.	Go to step 4.
<p><b>Step 4</b></p> <ul style="list-style-type: none"> <li><b>a</b> Delete some held jobs to free up printer memory.</li> <li><b>b</b> Resend the print job.</li> </ul> <p>Are the documents printed?</p>	The problem is solved.	Go to step 5.
<p><b>Step 5</b></p> <ul style="list-style-type: none"> <li><b>a</b> Add printer memory.</li> <li><b>b</b> Resend the print job.</li> </ul> <p>Are the documents printed?</p>	The problem is solved.	Contact <a href="#">customer support</a> .

## Slow printing

Action	Yes	No
<p><b>Step 1</b></p> <ul style="list-style-type: none"> <li><b>a</b> Make sure that the printer is not in Eco-Mode and Quiet Mode.</li> <li><b>b</b> Print the document.</li> </ul> <p>Is the printer still printing slow?</p>	Go to step 2.	The problem is solved.

Action	Yes	No
<p><b>Step 2</b></p> <p><b>a</b> Depending on your operating system, specify the paper type from the Printing Preferences or Print dialog.</p> <p><b>Notes:</b></p> <ul style="list-style-type: none"> <li>• Make sure that the setting matches the paper loaded in the tray.</li> <li>• You can also change the setting from the Paper menu on the printer control panel.</li> </ul> <p><b>b</b> Print the document.</p> <p>Is the printer still printing slow?</p>	Go to step 3.	The problem is solved.
<p><b>Step 3</b></p> <p><b>a</b> Reduce the number of pages to print.</p> <p><b>b</b> Print the document.</p> <p>Is the printer still printing slow?</p>	Go to step 4.	The problem is solved.
<p><b>Step 4</b></p> <p><b>a</b> Connect the printer cable securely to the printer and the computer, print server, option, or other network device.</p> <p><b>b</b> Print the document.</p> <p>Is the printer still printing slow?</p>	Go to step 5.	The problem is solved.
<p><b>Step 5</b></p> <p><b>a</b> From the Quality menu on the control panel, set Print Resolution to 600 dpi.</p> <p><b>b</b> Print the document.</p> <p>Is the printer still printing slow?</p>	Go to step 6.	The problem is solved.
<p><b>Step 6</b></p> <p><b>a</b> Make sure that the printer is not overheating.</p> <p><b>Notes:</b></p> <ul style="list-style-type: none"> <li>• Allow the printer to cool down after a very long print job.</li> <li>• Observe the recommended ambient temperature for the printer. For more information, see <a href="#">“Selecting a location for the printer” on page 9.</a></li> </ul> <p><b>b</b> Print the document.</p> <p>Is the printer still printing slow?</p>	Go to step 7.	The problem is solved.
<p><b>Step 7</b></p> <p><b>a</b> Add more printer memory.</p> <p><b>b</b> Print the document.</p> <p>Is the printer still printing slow?</p>	Contact <a href="#">customer support</a> .	The problem is solved.

## Print jobs do not print

Action	Yes	No
<p><b>Step 1</b></p> <p><b>a</b> From the document that you are trying to print, open the Print dialog, and then check if you selected the correct printer.</p> <p><b>b</b> Print the document.</p> <p>Is the document printed?</p>	The problem is solved.	Go to step 2.
<p><b>Step 2</b></p> <p><b>a</b> Check if the printer is on.</p> <p><b>b</b> Resolve any error messages that appear on the display.</p> <p><b>c</b> Print the document.</p> <p>Is the document printed?</p>	The problem is solved.	Go to step 3.
<p><b>Step 3</b></p> <p><b>a</b> Check if the ports are working, and if the cables are securely connected to the computer and the printer. For more information, see the setup documentation that came with the printer.</p> <p><b>b</b> Print the document.</p> <p>Is the document printed?</p>	The problem is solved.	Go to step 4.
<p><b>Step 4</b></p> <p><b>a</b> Turn off the printer, wait for about 10 seconds, and then turn it back on.</p> <p><b>b</b> Print the document.</p> <p>Is the document printed?</p>	The problem is solved.	Go to step 5.
<p><b>Step 5</b></p> <p><b>a</b> Remove, and then install the printer software.</p> <p><b>b</b> Print the document.</p> <p>Is the document printed?</p>	The problem is solved.	Contact <a href="#">customer support</a> .



## Print quality is poor

### Blank or white pages





**Note:** Before solving the problem, print the Print Quality Test Pages. From the control panel, navigate to **Settings > Troubleshooting > Print Quality Test Pages**. For non-touch-screen printer models, press **OK** to navigate through the settings.

Action	Yes	No
<p><b>Step 1</b></p> <p><b>a</b> Check if the printer is using a genuine and supported toner cartridge.</p> <p><b>Note:</b> If the cartridge is not supported, then install a supported one.</p> <p><b>b</b> Print the document.</p> <p>Is the printer printing blank or white pages?</p>	Go to step 2.	The problem is solved.
<p><b>Step 2</b></p> <p><b>a</b> Remove any packing material that is left on the imaging unit.</p> <p><b>1</b> Remove the toner cartridge, and then remove the imaging unit.</p> <p><b>Warning—Potential Damage:</b> Do not expose the imaging unit to direct light for more than 10 minutes. Extended exposure to light may cause print quality problems.</p> <p><b>Warning—Potential Damage:</b> Do not touch the photoconductor drum under the imaging unit. Doing so may affect the quality of future print jobs.</p> <p><b>2</b> Check the imaging unit for signs of damage, and replace if necessary.</p> <p><b>Note:</b> Make sure that the photoconductor drum contact is not bent or out of place.</p> <p><b>3</b> Firmly shake the imaging unit to redistribute the toner.</p> <p><b>4</b> Insert the imaging unit, and then insert the toner cartridge.</p> <p><b>b</b> Print the document.</p> <p>Is the printer printing blank or white pages?</p>	Go to step 3.	The problem is solved.

Action	Yes	No
<p><b>Step 3</b>                      Check the status of the toner cartridge, and replace if necessary.</p> <ul style="list-style-type: none"> <li><b>a</b> From the control panel, navigate to:  <b>Status/Supplies &gt; Supplies</b></li> <li><b>b</b> Print the document.</li> </ul> <p>Is the printer printing blank or white pages?</p>	<p>Contact <a href="#">customer support</a>.</p>	<p>The problem is solved.</p>

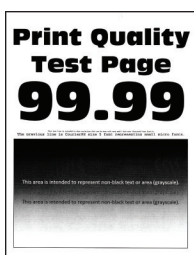
### Dark print



**Note:** Before solving the problem, print the Print Quality Test Pages. From the control panel, navigate to **Settings > Troubleshooting > Print Quality Test Pages**. For non-touch-screen printer models, press  to navigate through the settings.

Action	Yes	No
<p><b>Step 1</b></p> <ul style="list-style-type: none"> <li><b>a</b> Check if the printer is using a genuine and supported toner cartridge.  <b>Note:</b> If the cartridge is not supported, then install a supported one.</li> <li><b>b</b> Print the document.</li> </ul> <p>Is the print dark?</p>	<p>Go to step 2.</p>	<p>The problem is solved.</p>
<p><b>Step 2</b></p> <ul style="list-style-type: none"> <li><b>a</b> Turn off the printer, wait for about 10 seconds, and then turn on the printer.</li> <li><b>b</b> Reduce toner darkness. From the control panel, navigate to:  <b>Settings &gt; Print &gt; Quality</b></li> <li><b>c</b> Print the document.</li> </ul> <p>Is the print dark?</p>	<p>Go to step 3.</p>	<p>The problem is solved.</p>

Action	Yes	No
<p><b>Step 3</b></p> <p><b>a</b> Depending on your operating system, specify the paper type from the Printing Preferences or Print dialog.</p> <p><b>Notes:</b></p> <ul style="list-style-type: none"> <li>• Make sure that the setting matches the paper loaded.</li> <li>• You can also change the setting on the printer control panel.</li> </ul> <p><b>b</b> Print the document.</p> <p>Is the print dark?</p>	<p>Go to step 4.</p>	<p>The problem is solved.</p>
<p><b>Step 4</b></p> <p>Check if the paper has texture or rough finishes.</p> <p>Are you printing on textured or rough paper?</p>	<p>Go to step 5.</p>	<p>Go to step 6.</p>
<p><b>Step 5</b></p> <p><b>a</b> Replace textured paper with plain paper.</p> <p><b>b</b> Print the document.</p> <p>Is the print dark?</p>	<p>Go to step 6.</p>	<p>The problem is solved.</p>
<p><b>Step 6</b></p> <p><b>a</b> Load paper from a fresh package.</p> <p><b>Note:</b> Paper absorbs moisture due to high humidity. Store paper in its original wrapper until you are ready to use it.</p> <p><b>b</b> Print the document.</p> <p>Is the print dark?</p>	<p>Go to step 7.</p>	<p>The problem is solved.</p>
<p><b>Step 7</b></p> <p><b>a</b> Remove, and then insert the imaging unit.</p> <p><b>Warning—Potential Damage:</b> Do not expose the imaging unit to direct light for more than 10 minutes. Extended exposure to light may cause print quality problems.</p> <p><b>Warning—Potential Damage:</b> Do not touch the photoconductor drum under the imaging unit. Doing so may affect the quality of future print jobs.</p> <p><b>b</b> Print the document.</p> <p>Is the print dark?</p>	<p>Go to step 8.</p>	<p>The problem is solved.</p>
<p><b>Step 8</b></p> <p><b>a</b> Replace the imaging unit.</p> <p><b>b</b> Print the document.</p> <p>Is the print dark?</p>	<p>Contact <a href="#">customer support</a>.</p>	<p>The problem is solved.</p>

### Fine lines are not printed correctly

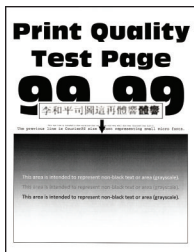

**Note:** Before solving the problem, print the Print Quality Test Pages. From the control panel, navigate to **Settings > Troubleshooting > Print Quality Test Pages**. For non-touch-screen printer models, press **OK** to navigate through the settings.

Action	Yes	No
<p><b>Step 1</b></p> <p><b>a</b> Check if the printer is using a genuine and supported toner cartridge.</p> <p><b>Note:</b> If the cartridge is not supported, then install a supported one.</p> <p><b>b</b> Print the document.</p> <p>Are fine lines not printed correctly?</p>	<p>Go to step 2.</p>	<p>The problem is solved.</p>
<p><b>Step 2</b></p> <p><b>a</b> Adjust the print quality settings.</p> <p><b>1</b> From the control panel, navigate to: <b>Settings &gt; Print &gt; Quality &gt; Pixel Boost &gt; Fonts</b></p> <p><b>2</b> Adjust Toner Darkness to 7. From the control panel, navigate to: <b>Settings &gt; Print &gt; Quality</b></p> <p><b>b</b> Print the document.</p> <p>Are fine lines not printed correctly?</p>	<p>Contact <a href="#">customer support</a>.</p>	<p>The problem is solved.</p>

### Folded or wrinkled paper

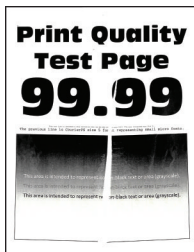

**Note:** Before solving the problem, print the Print Quality Test Pages. From the control panel, navigate to

**Settings > Troubleshooting > Print Quality Test Pages.** For non-touch-screen printer models, press **OK** to navigate through the settings.

Action	Yes	No
<p><b>Step 1</b></p> <p><b>a</b> Check if the printer is using a genuine and supported toner cartridge.</p> <p><b>Note:</b> If the cartridge is not supported, then install a supported one.</p> <p><b>b</b> Print the document.</p> <p>Is the paper folded or wrinkled?</p>	Go to step 2.	The problem is solved.
<p><b>Step 2</b></p> <p><b>a</b> Load paper from a fresh package.</p> <p><b>Note:</b> Paper absorbs moisture due to high humidity. Store paper in its original wrapper until you are ready to use it.</p> <p><b>b</b> Print the document.</p> <p>Is the paper folded or wrinkled?</p>	Go to step 3.	The problem is solved.
<p><b>Step 3</b></p> <p><b>a</b> Depending on your operating system, specify the paper type from the Printing Preferences or Print dialog.</p> <p><b>Notes:</b></p> <ul style="list-style-type: none"> <li>• Make sure that the setting matches the paper loaded.</li> <li>• You can also change the setting from the printer control panel.</li> </ul> <p><b>b</b> Print the document.</p> <p>Is the paper folded or wrinkled?</p>	Contact <a href="#">customer support</a> .	The problem is solved.

**Gray background**

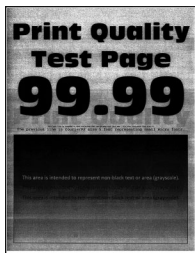

**Note:** Before solving the problem, print the Print Quality Test Pages. From the control panel, navigate to

**Settings > Troubleshooting > Print Quality Test Pages.** For non-touch-screen printer models, press **OK** to navigate through the settings.

Action	Yes	No
<p><b>Step 1</b></p> <p><b>a</b> Turn off the printer, wait for 10 seconds, and then turn on the printer.</p> <p><b>b</b> Increase toner darkness. From the control panel, navigate to: <b>Settings &gt; Print &gt; Quality</b></p> <p><b>c</b> Print the document.</p> <p>Does gray background appear on prints?</p>	Go to step 2.	The problem is solved.
<p><b>Step 2</b></p> <p><b>a</b> Check if the printer is using a genuine and supported toner cartridge. <b>Note:</b> If the toner cartridge is not supported, then install a supported one.</p> <p><b>b</b> Print the document.</p> <p>Does gray background appear on prints?</p>	Go to step 3.	The problem is solved.
<p><b>Step 3</b></p> <p><b>a</b> Depending on your operating system, specify the paper type from the Printing Preferences or Print dialog.</p> <p><b>Notes:</b></p> <ul style="list-style-type: none"> <li>• Make sure that the setting matches the paper loaded.</li> <li>• You can also change the setting from the printer control panel.</li> </ul> <p><b>b</b> Print the document.</p> <p>Does gray background appear on prints?</p>	Go to step 4.	The problem is solved.
<p><b>Step 4</b></p> <p>Check the status of the toner cartridge, and replace if necessary.</p> <p><b>a</b> From the control panel, navigate to: <b>Status/Supplies &gt; Supplies</b></p> <p><b>b</b> Print the document.</p> <p>Does gray background appear on prints?</p>	Go to step 5.	The problem is solved.

Action	Yes	No
<p><b>Step 5</b></p> <p><b>a</b> Remove the imaging unit.</p> <p><b>Warning—Potential Damage:</b> Do not expose the imaging unit to direct light for more than 10 minutes. Extended exposure to light may cause print quality problems.</p> <p><b>Warning—Potential Damage:</b> Do not touch the photoconductor drum under the imaging unit. Doing so may affect the quality of future print jobs.</p> <p><b>b</b> Remove any packing material that is stuck on the imaging unit.</p>  <p><b>Note:</b> Make sure to remove any obstruction between the charge roller and photoconductor drum.</p> <p><b>c</b> Insert the imaging unit.</p> <p><b>d</b> Print the document.</p> <p>Does gray background appear on prints?</p>	<p>Go to step 6.</p>	<p>The problem is solved.</p>
<p><b>Step 6</b></p> <p><b>a</b> Replace the imaging unit.</p> <p><b>b</b> Print the document.</p> <p>Does gray background appear on prints?</p>	<p>Contact <a href="#">customer support</a>.</p>	<p>The problem is solved.</p>

### Horizontal light bands



**Note:** Before solving the problem, print the Print Quality Test Pages. From the control panel, navigate to **Settings > Troubleshooting > Print Quality Test Pages**. For non-touch-screen printer models, press  to navigate through the settings.

Action	Yes	No
<p><b>a</b> Check if the printer is using a genuine and supported toner cartridge.</p> <p><b>Note:</b> If the cartridge is not supported, then install a supported one.</p> <p><b>b</b> Print the document.</p> <p>Do horizontal light bands appear on prints?</p>	Contact <a href="#">customer support</a> .	The problem is solved.

### Incorrect margins



Action	Yes	No
<p><b>Step 1</b></p> <p><b>a</b> Adjust the paper guides to the correct position for the paper loaded.</p> <p><b>b</b> Print the document.</p> <p>Are the margins correct?</p>	The problem is solved.	Go to step 2.
<p><b>Step 2</b></p> <p><b>a</b> Depending on your operating system, specify the paper size from the Printing Preferences or Print dialog.</p> <p><b>Notes:</b></p> <ul style="list-style-type: none"> <li>• Make sure that the setting matches the paper loaded.</li> <li>• You can also change the setting from the printer control panel.</li> </ul> <p><b>b</b> Print the document.</p> <p>Are the margins correct?</p>	The problem is solved.	Contact <a href="#">customer support</a> .



## Light print

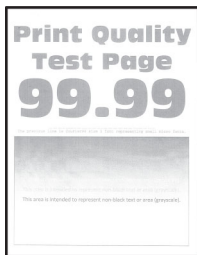

**Note:** Before solving the problem, print the Print Quality Test Pages. From the control panel, navigate to **Settings > Troubleshooting > Print Quality Test Pages**. For non-touch-screen printer models, press **OK** to navigate through the settings.

Action	Yes	No
<p><b>Step 1</b></p> <p><b>a</b> Check if the printer is using a genuine and supported toner cartridge.</p> <p><b>Note:</b> If the cartridge is not supported, then install a supported one.</p> <p><b>b</b> Print the document.</p> <p>Is the print light?</p>	Go to step 2.	The problem is solved.
<p><b>Step 2</b></p> <p><b>a</b> Turn off the printer, wait for about 10 seconds, and then turn on the printer.</p> <p><b>b</b> Increase toner darkness. From the control panel, navigate to: <b>Settings &gt; Print &gt; Quality</b></p> <p><b>c</b> Print the document.</p> <p>Is the print light?</p>	Go to step 3.	The problem is solved.
<p><b>Step 3</b></p> <p><b>a</b> Depending on your operating system, specify the paper type from the Printing Preferences or Print dialog.</p> <p><b>Notes:</b></p> <ul style="list-style-type: none"> <li>• Make sure that the setting matches the paper loaded.</li> <li>• You can also change the setting on the printer control panel.</li> </ul> <p><b>b</b> Print the document.</p> <p>Is the print light?</p>	Go to step 4.	The problem is solved.

Action	Yes	No
<p><b>Step 4</b> Check the status of the toner cartridge, and replace if necessary.</p> <ul style="list-style-type: none"> <li><b>a</b> From the control panel, navigate to: <b>Status/Supplies &gt; Supplies</b></li> <li><b>b</b> Print the document.</li> </ul> <p>Is the print light?</p>	<p>Go to step 5.</p>	<p>The problem is solved.</p>
<p><b>Step 5</b></p> <ul style="list-style-type: none"> <li><b>a</b> Remove the toner cartridge, and then remove the imaging unit. <b>Warning—Potential Damage:</b> Do not expose the imaging unit to direct light for more than 10 minutes. Extended exposure to light can cause print quality problems. <b>Warning—Potential Damage:</b> Do not touch the photoconductor drum under the imaging unit. Doing so may affect the quality of future print jobs.</li> <li><b>b</b> Push either side of the transfer roller, located below the imaging unit, to check if it depresses and bounces back into place.</li> <li><b>c</b> If the transfer roller does not depress and bounce back into place, then insert it by pulling up the blue gear and pulling it out from the right side to the left.</li> <li><b>d</b> Firmly shake the imaging unit to redistribute the toner, and then insert it.</li> <li><b>e</b> Insert the toner cartridge.</li> <li><b>f</b> Turn off the printer, wait for 10 seconds, and then turn on the printer.</li> <li><b>g</b> Print the document.</li> </ul> <p>Is the print light?</p>	<p>Go to step 6.</p>	<p>The problem is solved.</p>
<p><b>Step 6</b></p> <ul style="list-style-type: none"> <li><b>a</b> If the issue happens after installing a new maintenance kit, then check whether the transfer roller included with the kit is installed. <b>Note:</b> If necessary, replace the transfer roller.</li> <li><b>b</b> Print the document.</li> </ul> <p>Is the print light?</p>	<p>Go to step 7.</p>	<p>The problem is solved.</p>
<p><b>Step 7</b> Check the status of the imaging unit. From the control panel, navigate to: <b>Status/Supplies &gt; Supplies</b></p> <p>Is the imaging unit near end of life?</p>	<p>Go to step 8.</p>	<p>Contact <a href="#">customer support</a>.</p>

Action	Yes	No
<p><b>Step 8</b></p> <p><b>a</b> Replace the imaging unit.</p> <p><b>b</b> Print the document.</p> <p>Is the print light?</p>	<p>Contact <a href="#">customer support</a>.</p>	<p>The problem is solved.</p>

### Mottled print and dots



**Note:** Before solving the problem, print the Print Quality Test Pages. From the control panel, navigate to **Settings > Troubleshooting > Print Quality Test Pages**. For non-touch-screen printer models, press  to navigate through the settings.

Action	Yes	No
<p><b>Step 1</b></p> <p><b>a</b> Check if the printer is using a genuine and supported toner cartridge.</p> <p><b>Note:</b> If the toner cartridge is not supported, then install a supported one.</p> <p><b>b</b> Print the document.</p> <p>Is the print mottled?</p>	<p>Go to step 2.</p>	<p>The problem is solved.</p>
<p><b>Step 2</b></p> <p>Check the printer for leaked toner contamination.</p> <p>Is the printer free of leaked toner?</p>	<p>Go to step 4.</p>	<p>Go to step 3.</p>
<p><b>Step 3</b></p> <p><b>a</b> Replace the toner cartridge.</p> <p><b>b</b> Print the document.</p> <p>Is the print mottled?</p>	<p>Go to step 4.</p>	<p>The problem is solved.</p>
<p><b>Step 4</b></p> <p>Check the status of the imaging unit. From the control panel, navigate to:</p> <p><b>Status/Supplies &gt; Supplies</b></p> <p>Is the imaging unit near end of life?</p>	<p>Go to step 5.</p>	<p>Contact <a href="#">customer support</a>.</p>

Action	Yes	No
<p><b>Step 5</b></p> <p><b>a</b> Replace the imaging unit.</p> <p><b>b</b> Print the document.</p> <p>Is the print mottled?</p>	<p>Contact <a href="#">customer support</a>.</p>	<p>The problem is solved.</p>

**Paper curl**



**Note:** Before solving the problem, print the Print Quality Test Pages. From the control panel, navigate to **Settings > Troubleshooting > Print Quality Test Pages**. For non-touch-screen printer models, press  to navigate through the settings.

Action	Yes	No
<p><b>Step 1</b></p> <p><b>a</b> Check if the printer is using a genuine and supported toner cartridge.</p> <p><b>Note:</b> If the cartridge is not supported, then install a supported one.</p> <p><b>b</b> Print the document.</p> <p>Is the paper curled?</p>	<p>Go to step 2.</p>	<p>The problem is solved.</p>
<p><b>Step 2</b></p> <p><b>a</b> Adjust the guides in the tray to the correct position for the paper loaded.</p> <p><b>b</b> Print the document.</p> <p>Is the paper curled?</p>	<p>Go to step 3.</p>	<p>The problem is solved.</p>

Action	Yes	No
<p><b>Step 3</b></p> <p><b>a</b> Depending on your operating system, specify the paper size and paper type from the Printing Preferences or Print dialog.</p> <p><b>Notes:</b></p> <ul style="list-style-type: none"> <li>• Make sure that the settings match the paper loaded.</li> <li>• You can also change the settings from the printer control panel.</li> </ul> <p><b>b</b> Print the document.</p> <p>Is the paper curled?</p>	Go to step 4.	The problem is solved.
<p><b>Step 4</b></p> <p><b>a</b> Remove paper from the tray, and then turn over the paper.</p> <p><b>b</b> Print the document.</p> <p>Is the paper curled?</p>	Go to step 5.	The problem is solved.
<p><b>Step 5</b></p> <p><b>a</b> Load paper from a fresh package.</p> <p><b>Note:</b> Paper absorbs moisture due to high humidity. Store paper in its original wrapper until you are ready to use it.</p> <p><b>b</b> Print the document.</p> <p>Is the paper curled?</p>	Go to step 6.	The problem is solved.
<p><b>Step 6</b></p> <p><b>a</b> Check if the paper loaded is supported.</p> <p><b>Note:</b> If paper is not supported, then load a supported paper.</p> <p><b>b</b> Print the document.</p> <p>Is the paper curled?</p>	Contact <a href="#">customer support</a> .	The problem is solved.

### Print crooked or skewed



**Note:** Before solving the problem, print the Print Quality Test Pages. From the control panel, navigate to **Settings > Troubleshooting > Print Quality Test Pages**. For non-touch-screen printer models, press **OK** to navigate through the settings.

Action	Yes	No
<p><b>Step 1</b></p> <p><b>a</b> Adjust the guides in the tray to the correct position for the paper loaded.</p> <p><b>b</b> Print the document.</p> <p>Is the print crooked or skewed?</p>	Go to step 2.	The problem is solved.
<p><b>Step 2</b></p> <p><b>a</b> Check if the paper loaded is supported.</p> <p><b>Note:</b> If paper is not supported, then load a supported paper.</p> <p><b>b</b> Print the document.</p> <p>Is the print crooked or skewed?</p>	Go to step 3.	The problem is solved.
<p><b>Step 3</b></p> <p><b>a</b> Check the pick tire in the tray for signs of damage and contamination, and replace if necessary.</p> <p><b>b</b> Print the document.</p> <p>Is the print crooked or skewed?</p>	Contact <a href="#">customer support</a> .	The problem is solved.

**Repeating defects**



**Note:** Before solving the problem, print the Print Quality Test Pages. From the control panel, navigate to **Settings > Troubleshooting > Print Quality Test Pages**. For non-touch-screen printer models, press  to navigate through the settings.

Action	Yes	No
<p><b>Step 1</b></p> <p>Using the Print Quality Test Pages, check if the distance between the repeating defects is equal to any of the following:</p> <ul style="list-style-type: none"> <li>• 97 mm (3.82 in.)</li> <li>• 47 mm (1.85 in.)</li> <li>• 38 mm (1.5 in.)</li> </ul> <p>Does the distance between the repeating defects match any of the measurements?</p>	Go to step 2.	Take note of the distance, and then contact <a href="#">customer support</a> .

Action	Yes	No
<p><b>Step 2</b></p> <p><b>a</b> Replace the imaging unit.</p> <p><b>b</b> Print the document.</p> <p>Do the repeating defects appear?</p>	<p>Contact <a href="#">customer support</a>.</p>	<p>The problem is solved.</p>

### Solid black pages



**Note:** Before solving the problem, print the Print Quality Test Pages. From the control panel, navigate to **Settings > Troubleshooting > Print Quality Test Pages**. For non-touch-screen printer models, press  to navigate through the settings.

Action	Yes	No
<p><b>Step 1</b></p> <p><b>a</b> Check if the printer is using a genuine and supported toner cartridge.</p> <p><b>Note:</b> If the toner cartridge is not supported, then install a supported one.</p> <p><b>b</b> Print the document.</p> <p>Is the printer printing solid black pages?</p>	<p>Go to step 2.</p>	<p>The problem is solved.</p>
<p><b>Step 2</b></p> <p><b>a</b> Remove, and then insert the imaging unit.</p> <p><b>Warning—Potential Damage:</b> Do not expose the imaging unit to direct light for more than 10 minutes. Extended exposure to light may cause print quality problems.</p> <p><b>Warning—Potential Damage:</b> Do not touch the photoconductor drum under the imaging unit. Doing so may affect the quality of future print jobs.</p> <p><b>b</b> Print the document.</p> <p>Is the printer printing solid black pages?</p>	<p>Go to step 3.</p>	<p>The problem is solved.</p>

Action	Yes	No
<p><b>Step 3</b></p> <p><b>a</b> Remove the imaging unit.</p> <p><b>Warning—Potential Damage:</b> Do not expose the imaging unit to direct light for more than 10 minutes. Extended exposure to light may cause print quality problems.</p> <p><b>Warning—Potential Damage:</b> Do not touch the photoconductor drum under the imaging unit. Doing so may affect the quality of future print jobs.</p> <p><b>b</b> Remove any packing material that is stuck on the imaging unit.</p>  <p><b>Note:</b> Make sure to remove any obstruction between the charge roller and photoconductor drum.</p> <p><b>c</b> Insert the imaging unit.</p> <p><b>d</b> Print the document.</p> <p>Is the printer printing solid black pages?</p>	<p>Go to step 4.</p>	<p>The problem is solved.</p>
<p><b>Step 4</b></p> <p>Check the imaging unit for signs of damage.</p> <p>Is the imaging unit free from damage?</p>	<p>Contact <a href="#">customer support</a>.</p>	<p>Go to step 5.</p>
<p><b>Step 5</b></p> <p><b>a</b> Replace the imaging unit.</p> <p><b>b</b> Print the document.</p> <p>Is the printer printing solid black pages?</p>	<p>Contact <a href="#">customer support</a>.</p>	<p>The problem is solved.</p>

**Text or images cut off**



**Note:** Before solving the problem, print the Print Quality Test Pages. From the control panel, navigate to **Settings > Troubleshooting > Print Quality Test Pages**. For non-touch-screen printer models, press  to navigate through the settings.



Action	Yes	No
<p><b>Step 1</b></p> <p><b>a</b> Check if the printer is using a genuine and supported toner cartridge.</p> <p><b>Note:</b> If the toner cartridge is not supported, then install a supported one.</p> <p><b>b</b> Print the document.</p> <p>Are text or images cut off?</p>	<p>Go to step 2.</p>	<p>The problem is solved.</p>
<p><b>Step 2</b></p> <p><b>a</b> Remove, and then insert the imaging unit.</p> <p><b>Warning—Potential Damage:</b> Do not expose the imaging unit to direct light for more than 10 minutes. Extended exposure to light may cause print quality problems.</p> <p><b>Warning—Potential Damage:</b> Do not touch the photoconductor drum under the imaging unit. Doing so may affect the quality of future print jobs.</p> <p><b>b</b> Print the document.</p> <p>Are text or images cut off?</p>	<p>Go to step 3.</p>	<p>The problem is solved.</p>
<p><b>Step 3</b></p> <p><b>a</b> Remove the imaging unit.</p> <p><b>Warning—Potential Damage:</b> Do not expose the imaging unit to direct light for more than 10 minutes. Extended exposure to light may cause print quality problems.</p> <p><b>Warning—Potential Damage:</b> Do not touch the photoconductor drum under the imaging unit. Doing so may affect the quality of future print jobs.</p> <p><b>b</b> Remove any packing material that is stuck on the imaging unit.</p> <div data-bbox="402 1373 776 1514" data-label="Image"> </div> <p><b>Note:</b> Make sure to remove any obstruction between the charge roller and photoconductor drum.</p> <p><b>c</b> Insert the imaging unit.</p> <p><b>d</b> Print the document.</p> <p>Are text or images cut off?</p>	<p>Go to step 4.</p>	<p>The problem is solved.</p>
<p><b>Step 4</b></p> <p><b>a</b> Replace the imaging unit.</p> <p><b>b</b> Print the document.</p> <p>Are text or images cut off?</p>	<p>Contact <a href="#">customer support</a>.</p>	<p>The problem is solved.</p>

### Toner easily rubs off



**Note:** Before solving the problem, print the Print Quality Test Pages. From the control panel, navigate to **Settings > Troubleshooting > Print Quality Test Pages**. For non-touch-screen printer models, press **OK** to navigate through the settings.

Action	Yes	No
<p><b>Step 1</b></p> <p><b>a</b> Check if the printer is using a genuine and supported toner cartridge.</p> <p><b>Note:</b> If the toner cartridge is not supported, then install a supported one.</p> <p><b>b</b> Print the document.</p> <p>Does the toner easily rub off?</p>	<p>Go to step 2.</p>	<p>The problem is solved.</p>
<p><b>Step 2</b></p> <p><b>a</b> Depending on your operating system, specify the paper type from the Printing Preferences or Print dialog.</p> <p><b>Notes:</b></p> <ul style="list-style-type: none"> <li>• Make sure that the setting matches the paper loaded.</li> <li>• You can also change the setting on the printer control panel.</li> </ul> <p><b>b</b> Print the document.</p> <p>Does the toner easily rub off?</p>	<p>Contact <a href="#">customer support</a>.</p>	<p>The problem is solved.</p>

### Vertical dark bands

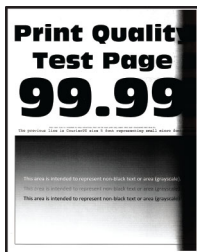

**Note:** Before solving the problem, print the Print Quality Test Pages. From the control panel, navigate to **Settings > Troubleshooting > Print Quality Test Pages**. For non-touch-screen printer models, press **OK** to navigate through the settings.

Action	Yes	No
<p><b>Step 1</b></p> <p><b>a</b> Check if the printer is using a genuine and supported toner cartridge.</p> <p><b>Note:</b> If the toner cartridge is not supported, then install a supported one.</p> <p><b>b</b> Print the document.</p> <p>Do vertical dark bands appear on prints?</p>	Go to step 2.	The problem is solved.
<p><b>Step 2</b></p> <p><b>a</b> Remove the toner cartridge, and then remove the imaging unit.</p> <p><b>Warning—Potential Damage:</b> Do not expose the imaging unit to direct light for more than 10 minutes. Extended exposure to light may cause print quality problems.</p> <p><b>Warning—Potential Damage:</b> Do not touch the photoconductor drum under the imaging unit. Doing so may affect the quality of future print jobs.</p> <p><b>b</b> Insert the imaging unit, and then insert the cartridge.</p> <p><b>c</b> Print the document.</p> <p>Do vertical dark bands appear on prints?</p>	Go to step 3.	The problem is solved.
<p><b>Step 3</b></p> <p><b>a</b> Remove the imaging unit.</p> <p><b>Warning—Potential Damage:</b> Do not expose the imaging unit to direct light for more than 10 minutes. Extended exposure to light may cause print quality problems.</p> <p><b>Warning—Potential Damage:</b> Do not touch the photoconductor drum under the imaging unit. Doing so may affect the quality of future print jobs.</p> <p><b>b</b> Remove any packing material that is stuck on the imaging unit.</p>  <p><b>Note:</b> Make sure to remove any obstruction between the charge roller and photoconductor drum.</p> <p><b>c</b> Insert the imaging unit.</p> <p><b>d</b> Print the document.</p> <p>Do vertical dark bands appear on prints?</p>	Go to step 4.	The problem is solved.

Action	Yes	No
<p><b>Step 4</b></p> <p><b>a</b> Check if a bright light enters the right side of the printer, and move the printer if necessary.</p> <p><b>b</b> Print the document.</p> <p>Do vertical dark bands appear on prints?</p>	<p>Contact <a href="#">customer support</a>.</p>	<p>The problem is solved.</p>

**Vertical dark lines or streaks**

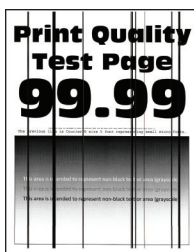



Action	Yes	No
<p><b>Step 1</b></p> <p><b>a</b> From the control panel, navigate to: <b>Settings &gt; Troubleshooting &gt; Cleaning the scanner</b></p> <p><b>b</b> Print the document.</p> <p>Do vertical dark lines or streaks appear on prints?</p>	<p>Go to step 3.</p>	<p>Go to step 2.</p>
<p><b>Step 2</b></p> <p><b>a</b> Using a damp, soft, lint-free cloth, clean the scanner. For more information, see "<a href="#">Cleaning the scanner</a>" on page 136.</p> <p><b>b</b> Copy the document using the ADF.</p> <p>Do vertical dark lines or streaks appear on prints?</p>	<p>Contact <a href="#">customer support</a>.</p>	<p>The problem is solved.</p>
<p><b>Step 3</b></p> <p><b>a</b> Check if the printer is using a genuine and supported toner cartridge.</p> <p><b>Note:</b> If the toner cartridge is not supported, then install a supported one.</p> <p><b>b</b> Print the document.</p> <p>Do vertical dark lines or streaks appear on prints?</p>	<p>Go to step 4.</p>	<p>The problem is solved.</p>

Action	Yes	No
<p><b>Step 4</b></p> <p><b>a</b> Remove, and then insert the imaging unit.</p> <p><b>Warning—Potential Damage:</b> Do not expose the imaging unit to direct light for more than 10 minutes. Extended exposure to light can cause print quality problems.</p> <p><b>Warning—Potential Damage:</b> Do not touch the photoconductor drum under the imaging unit. Doing so may affect the quality of future print jobs.</p> <p><b>b</b> Print the document.</p> <p>Do vertical dark lines or streaks appear on prints?</p>	Go to step 5.	The problem is solved.
<p><b>Step 5</b></p> <p><b>a</b> Replace the imaging unit.</p> <p><b>b</b> Print the document.</p> <p>Do vertical dark lines or streaks appear on prints?</p>	Contact <a href="#">customer support</a> .	The problem is solved.

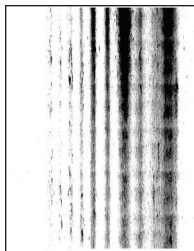
### Vertical dark streaks with print missing



**Note:** Before solving the problem, print the Print Quality Test Pages. From the control panel, navigate to **Settings > Troubleshooting > Print Quality Test Pages**. For non-touch-screen printer models, press  to navigate through the settings.

Action	Yes	No
<p><b>Step 1</b></p> <p><b>a</b> Remove the imaging unit.</p> <p><b>Warning—Potential Damage:</b> Do not expose the imaging unit to direct light for more than 10 minutes. Extended exposure to light may cause print quality problems.</p> <p><b>Warning—Potential Damage:</b> Do not touch the photoconductor drum under the imaging unit. Doing so may affect the quality of future print jobs.</p> <p><b>b</b> Remove any packing material that is stuck on the imaging unit.</p>  <p><b>Note:</b> Make sure to remove any obstruction between the charge roller and photoconductor drum.</p> <p><b>c</b> Insert the imaging unit.</p> <p><b>d</b> Print the document.</p> <p>Do vertical dark streaks with missing images appear on prints?</p>	<p>Go to step 2.</p>	<p>The problem is solved.</p>
<p><b>Step 2</b></p> <p><b>a</b> Check if the printer is using a genuine and supported toner cartridge.</p> <p><b>Note:</b> If the toner cartridge is not supported, then install a supported one.</p> <p><b>b</b> Print the document.</p> <p>Do vertical dark streaks with missing images appear on prints?</p>	<p>Contact <a href="#">customer support</a>.</p>	<p>The problem is solved.</p>

### Vertical light bands



**Note:** Before solving the problem, print the Print Quality Test Pages. From the control panel, navigate to **Settings > Troubleshooting > Print Quality Test Pages**. For non-touch-screen printer models, press  to navigate through the settings.

Action	Yes	No
<p><b>a</b> Check if the printer is using a genuine and supported toner cartridge.</p> <p><b>Note:</b> If the cartridge is not supported, then install a supported one.</p> <p><b>b</b> Print the document.</p> <p>Do vertical light bands appear on prints?</p>	<p>Contact <a href="#">customer support</a>.</p>	<p>The problem is solved.</p>

### Vertical white lines



**Note:** Before solving the problem, print the Print Quality Test Pages. From the control panel, navigate to **Settings > Troubleshooting > Print Quality Test Pages**. For non-touch-screen printer models, press  to navigate through the settings.

Action	Yes	No
<p><b>Step 1</b></p> <p><b>a</b> Check if the printer is using a genuine and supported toner cartridge.</p> <p><b>Note:</b> If the cartridge is not supported, then install a supported one.</p> <p><b>b</b> Print the document.</p> <p>Do vertical white lines appear on prints?</p>	<p>Go to step 2.</p>	<p>The problem is solved.</p>
<p><b>Step 2</b></p> <p><b>a</b> Depending on your operating system, specify the paper type from the Printing Preferences or Print dialog.</p> <p><b>Notes:</b></p> <ul style="list-style-type: none"> <li>• Make sure that the setting matches the paper loaded.</li> <li>• You can also change the setting on the printer control panel.</li> </ul> <p><b>b</b> Print the document.</p> <p>Do vertical white lines appear on prints?</p>	<p>Contact <a href="#">customer support</a>.</p>	<p>The problem is solved.</p>

## The printer is not responding

Action	Yes	No
<p><b>Step 1</b> Connect the power cord to the electrical outlet.</p> <p> <b>CAUTION—POTENTIAL INJURY:</b> To avoid the risk of fire or electrical shock, connect the power cord to an appropriately rated and properly grounded electrical outlet that is near the product and easily accessible.</p> <p>Is the printer responding?</p>	The problem is solved.	Go to step 2.
<p><b>Step 2</b> Check if the electrical outlet is turned off by a switch or breaker.</p> <p>Is the electrical outlet turned off by a switch or breaker?</p>	Turn on the switch or reset the breaker.	Go to step 3.
<p><b>Step 3</b> Check if the printer is on.</p> <p>Is the printer on?</p>	Go to step 4.	Turn on the printer.
<p><b>Step 4</b> Check if the printer is in sleep or hibernate mode.</p> <p>Is the printer in sleep or hibernate mode?</p>	Press the power button to wake the printer.	Go to step 5.
<p><b>Step 5</b> Check if the cables connecting the printer and the computer are inserted in the correct ports.</p> <p>Are the cables inserted in the correct ports?</p>	Go to step 6.	<p>Make sure to match the following:</p> <ul style="list-style-type: none"> <li>• The USB cable with the USB port on the printer</li> <li>• The Ethernet cable with the Ethernet port on the printer</li> </ul>
<p><b>Step 6</b> Turn off the printer, reinstall the hardware options, and then turn it back on.</p> <p>For more information, see the documentation that came with the option.</p> <p>Is the printer responding?</p>	The problem is solved	Go to step 7.
<p><b>Step 7</b> Install the correct print driver.</p> <p>Is the printer responding?</p>	The problem is solved	Go to step 8.



Action	Yes	No
<p><b>Step 8</b> Turn off the printer, wait for about 10 seconds, and then turn it back on.</p> <p>Is the printer responding?</p>	The problem is solved.	Contact <a href="#">customer support</a> .

## Adjusting toner darkness

- 1 From the home screen, touch **Settings > Print > Quality**.
- 2 Adjust the toner darkness.
- 3 Apply the changes.

## Job prints from the wrong tray or on the wrong paper

Action	Yes	No
<p><b>Step 1</b> <b>a</b> Check if you are printing on the correct paper. <b>b</b> Print the document.</p> <p>Is the document printed on the correct paper?</p>	Go to step 2.	Load the correct paper size and paper type.
<p><b>Step 2</b> <b>a</b> Depending on your operating system, specify the paper size and paper type from the Printing Preferences or Print dialog.</p> <p><b>Notes:</b></p> <ul style="list-style-type: none"> <li>• Make sure that the settings match the paper loaded in the tray.</li> <li>• You can also change the settings on the printer control panel.</li> </ul> <p><b>b</b> Print the document.</p> <p>Is the document printed from the correct tray or on the correct paper?</p>	The problem is solved.	Go to step 3.
<p><b>Step 3</b> <b>a</b> Check if the trays are not linked. For more information, see <a href="#">“Linking trays” on page 22</a>. <b>b</b> Print the document.</p> <p>Is the document printed from the correct tray?</p>	The problem is solved.	Contact <a href="#">customer support</a> .

# Faxing problems

## Cannot send or receive faxes

Action	Yes	No
<p><b>Step 1</b> Resolve any error messages that appear on the display.</p> <p>Can you send or receive a fax?</p>	The problem is solved.	Go to step 2.
<p><b>Step 2</b> Make sure that the cable connections for the following equipment are secure:</p> <ul style="list-style-type: none"> <li>• Telephone</li> <li>• Handset</li> <li>• Answering machine</li> </ul> <p>Can you send or receive a fax?</p>	The problem is solved.	Go to step 3.
<p><b>Step 3</b> Check for a dial tone.</p> <ul style="list-style-type: none"> <li>• Call the fax number to check if it is working properly.</li> <li>• If you are using the On Hook Dial feature, then turn up the volume to check if you hear a dial tone.</li> </ul> <p>Can you hear a dial tone?</p>	Go to step 5.	Go to step 4.
<p><b>Step 4</b> Check the telephone wall jack.</p> <ul style="list-style-type: none"> <li><b>a</b> Connect the analog telephone directly to the wall jack.</li> <li><b>b</b> Listen for a dial tone.</li> <li><b>c</b> If you do not hear a dial tone, then use a different telephone cable.</li> <li><b>d</b> If you still do not hear a dial tone, then connect the analog telephone to a different wall jack.</li> <li><b>e</b> If you hear a dial tone, then connect the printer to that wall jack.</li> </ul> <p>Can you send or receive a fax?</p>	The problem is solved.	Go to step 5.

Action	Yes	No
<p><b>Step 5</b></p> <p>Check if the printer is connected to an analog phone service or to the correct digital connector.</p> <ul style="list-style-type: none"> <li>• If you are using an Integrated Services for Digital Network (ISDN) telephone service, then connect to an analog telephone port of an ISDN terminal adapter. For more information, contact your ISDN provider.</li> <li>• If you are using DSL, then connect to a DSL filter or router that supports analog use. For more information, contact your DSL provider.</li> <li>• If you are using a private branch exchange (PBX) telephone service, then make sure that you are connecting to an analog connection on the PBX. If none exists, then consider installing an analog telephone line for the fax machine.</li> </ul> <p>Can you send or receive a fax?</p>	<p>The problem is solved.</p>	<p>Go to step 6.</p>
<p><b>Step 6</b></p> <p>Temporarily disconnect other equipment and disable other telephone services.</p> <ol style="list-style-type: none"> <li>a Disconnect other equipment (such as answering machines, computers, modems, or telephone line splitters) between the printer and the telephone line.</li> <li>b Disable call waiting and voice mail. For more information, contact your telephone company.</li> </ol> <p>Can you send or receive a fax?</p>	<p>The problem is solved.</p>	<p>Go to step 7.</p>
<p><b>Step 7</b></p> <p>Scan the original document one page at a time.</p> <ol style="list-style-type: none"> <li>a Dial the fax number.</li> <li>b Scan the document.</li> </ol> <p>Can you send or receive a fax?</p>	<p>The problem is solved.</p>	<p>Contact <a href="#">customer support</a>.</p>

### Can receive but not send faxes

Action	Yes	No
<p><b>Step 1</b> Load the original document properly into the ADF tray or on the scanner glass.</p> <p>Can you send faxes?</p>	The problem is solved.	Go to step 2.
<p><b>Step 2</b> Set up the shortcut number properly.</p> <ul style="list-style-type: none"> <li>• Check if the shortcut number is set for the telephone number that you want to dial.</li> <li>• Dial the telephone number manually.</li> </ul> <p>Can you send faxes?</p>	The problem is solved.	Contact <a href="#">customer support</a> .

### Can send but not receive faxes

Action	Yes	No
<p><b>Step 1</b> Make sure that the paper source is not empty.</p> <p>Can you receive faxes?</p>	The problem is solved.	Go to step 2.
<p><b>Step 2</b> Check the ring count delay settings.</p> <p>From the control panel, navigate to: <b>Settings &gt; Fax &gt; Analog Fax Setup &gt; Fax Receive Settings &gt; Rings to Answer</b></p> <p>For non-touch-screen printer models, press  to navigate through the settings.</p> <p>Can you receive faxes?</p>	The problem is solved.	Contact <a href="#">customer support</a> .

### Poor fax print quality

Action	Yes	No
<p><b>Step 1</b> Enhance the print quality.</p> <ol style="list-style-type: none"> <li>From the home screen, touch <b>Settings &gt; Print &gt; Quality</b>.</li> <li>Adjust the settings.</li> </ol> <p>Is the fax print quality satisfactory?</p>	The problem is solved.	Go to step 2.

Action	Yes	No
<p><b>Step 2</b> Decrease the incoming fax transmission speed.</p> <p><b>a</b> From the home screen, touch <b>Settings &gt; Fax &gt; Analog Fax Setup &gt; Fax Receive Settings &gt; Admin Controls &gt; Max Speed.</b></p> <p><b>b</b> Select a lower transmission speed.</p> <p>Is the fax print quality satisfactory?</p>	The problem is solved.	Go to step 3.
<p><b>Step 3</b> Replace the toner cartridge. For more information, see the instruction sheet that came with the supply.</p> <p>Is the fax print quality satisfactory?</p>	The problem is solved.	Contact <a href="#">customer support</a> .

## Scanning problems

### Cannot scan from a computer

Action	Yes	No
<p><b>Step 1</b></p> <p><b>a</b> Turn off the printer, wait for about 10 seconds, and then turn it back on.</p> <p><b>b</b> Resend the scan job.</p> <p>Can you send the scan job?</p>	The problem is solved.	Go to step 2.
<p><b>Step 2</b></p> <p><b>a</b> Make sure that the cables between the printer and the print server are secure. For more information, see the setup documentation that came with the printer.</p> <p><b>b</b> Resend the scan job.</p> <p>Can you send the scan job?</p>	The problem is solved.	Contact <a href="#">customer support</a> .

### Partial copies of document or photo

Action	Yes	No
<p><b>Step 1</b></p> <p><b>a</b> Make sure that the document or photo is loaded facedown on the upper left corner of the scanner glass.</p> <p><b>b</b> Copy the document or photo.</p> <p>Is the document or photo copied correctly?</p>	The problem is solved.	Go to step 2.
<p><b>Step 2</b></p> <p><b>a</b> Match the paper size setting and the paper loaded in the tray.</p> <p><b>b</b> Copy the document or photo.</p> <p>Is the document or photo copied correctly?</p>	The problem is solved.	Contact <a href="#">customer support</a> .

### Poor copy quality

Action	Yes	No
<p><b>Step 1</b></p> <p><b>a</b> Using a damp, soft, lint-free cloth, wipe the scanner glass and the ADF glass.</p> <p><b>b</b> Make sure that the document or photo is loaded facedown on the upper-left corner of the scanner glass.</p> <p><b>c</b> Copy the document or photo.</p> <p>Is the copy quality satisfactory?</p>	The problem is solved.	Go to step 2.
<p><b>Step 2</b></p> <p><b>a</b> Check the quality of the original document or photo.</p> <p><b>b</b> Adjust the scan quality settings.</p> <p><b>c</b> Copy the document or photo.</p> <p>Is the copy quality satisfactory?</p>	The problem is solved.	Contact <a href="#">customer support</a> .

### Vertical dark streaks on output when scanning from the ADF

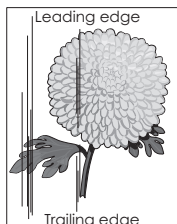
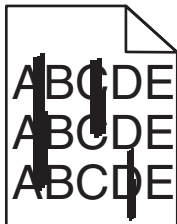

Action	Yes	No
<p><b>Step 1</b></p> <p><b>a</b> Open the scanner cover.</p> <p><b>b</b> Using a damp, soft, lint-free cloth, wipe the ADF glass and the white underside of the scanner cover.</p> <p><b>c</b> Close the scanner cover.</p> <p>Do vertical streaks appear on scanned documents?</p>	Go to step 2.	The problem is solved.
<p><b>Step 2</b></p> <p><b>a</b> Open the ADF cover.</p> <p><b>b</b> Using a damp, soft, lint-free cloth, wipe the ADF glass and the white underside of the ADF cover.</p> <p><b>c</b> Close the ADF cover.</p> <p>Do vertical streaks appear on scanned documents?</p>	Contact <a href="#">customer support</a> .	The problem is solved.

### Scan job was not successful

Action	Yes	No
<p><b>Step 1</b></p> <p>Check the cable connections.</p> <p><b>a</b> Make sure that the Ethernet or USB cable is securely connected to the computer and the printer.</p> <p><b>b</b> Resend the scan job.</p> <p>Is the scan job successful?</p>	The problem is solved.	Go to step 2.
<p><b>Step 2</b></p> <p>Check the file you want to scan.</p> <p><b>a</b> Make sure that the file name is not already used in the destination folder.</p> <p><b>b</b> Make sure that the document or photo you want to scan is not open in another application.</p> <p><b>c</b> Resend the scan job.</p> <p>Is the scan job successful?</p>	The problem is solved.	Go to step 3.
<p><b>Step 3</b></p> <p><b>a</b> Make sure that the <b>Append time stamp</b> or the <b>Overwrite existing file</b> check box is selected in the destination configuration settings.</p> <p><b>b</b> Resend the scan job.</p> <p>Is the scan job successful?</p>	The problem is solved.	Contact <a href="#">customer support</a> .

### Scanner does not close

Action	Yes	No
Remove obstructions that keep the scanner unit open.  Did the scanner unit close correctly?	The problem is solved.	Contact <a href="#">customer support</a> .

### Scanning takes too long or freezes the computer

Action	Yes	No
Close all applications that are interfering with the scan.  Does scanning take too long or freeze the computer?	Contact <a href="#">customer support</a> .	The problem is solved.

### Scanner does not respond

Action	Yes	No
<p><b>Step 1</b></p> <ul style="list-style-type: none"> <li><b>a</b> Check if the printer is turned on.</li> <li><b>b</b> Resolve any error messages that appear on the display.</li> <li><b>c</b> Copy or scan the document.</li> </ul> <p>Is the scanner responding?</p>	The problem is solved.	Go to step 2.
<p><b>Step 2</b></p> <ul style="list-style-type: none"> <li><b>a</b> Check if the power cord is connected properly to the printer and the electrical outlet.</li> </ul> <p> <b>CAUTION—POTENTIAL INJURY:</b> To avoid the risk of fire or electrical shock, connect the power cord to an appropriately rated and properly grounded electrical outlet that is near the product and easily accessible.</p> <ul style="list-style-type: none"> <li><b>b</b> Copy or scan the document.</li> </ul> <p>Is the scanner responding?</p>	The problem is solved.	Go to step 3.
<p><b>Step 3</b></p> <ul style="list-style-type: none"> <li><b>a</b> Turn off the printer, wait for about 10 seconds, and then turn it back on.</li> <li><b>b</b> Copy or scan the document.</li> </ul> <p>Is the scanner responding?</p>	The problem is solved.	Contact <a href="#">customer support</a> .



## Adjusting scanner registration

- 1 From the control panel, navigate to:  
**Settings > Device > Maintenance > Config Menu > Scanner Configuration > Scanner Manual Registration**
- 2 In the Print Quick Test menu, touch **Start**.
- 3 Place the Print Quick Test page on the scanner glass, and then touch **Flatbed Registration**.
- 4 In the Copy Quick Test menu, touch **Start**.
- 5 Compare the Copy Quick Test page with the original document.  
**Note:** If the margins of the test page are different from the original document, then adjust Left Margin and Top Margin.
- 6 Repeat [step 4](#) and [step 5](#) until the margins of the Copy Quick Test page closely match the original document.

## Adjusting ADF registration

- 1 From the control panel, navigate to:  
**Settings > Device > Maintenance > Config Menu > Scanner Configuration > Scanner Manual Registration**
- 2 In the Print Quick Test menu, touch **Start**.
- 3 Place the Print Quick Test page on the ADF tray.
- 4 Touch **Front ADF Registration** or **Rear ADF Registration**.  
**Notes:**
  - To align Front ADF Registration, place the test page faceup, short edge first into the ADF.
  - To align Rear ADF Registration, place the test page facedown, short edge first into the ADF.
- 5 In the Copy Quick Test menu, touch **Start**.
- 6 Compare the Copy Quick Test page with the original document.  
**Note:** If the margins of the test page are different from the original document, then adjust Horizontal Adjust and Top Margin.
- 7 Repeat [step 5](#) and [step 6](#) until the margins of the Copy Quick Test page closely match the original document.

## Contacting customer support

Before contacting customer support, make sure to have the following information:

- Printer problem
- Error message
- Printer model type and serial number

Visit the place where you purchased your printer.

# Upgrading and migrating

## Hardware

### Available internal options

- User Flash
- Font cards
- Firmware cards
  - Bar Code
  - IPDS
- Printer hard disk

### Accessing the controller board

 **CAUTION—SHOCK HAZARD:** To avoid the risk of electrical shock, if you are accessing the controller board or installing optional hardware or memory devices sometime after setting up the printer, then turn the printer off, and unplug the power cord from the electrical outlet before continuing. If you have any other devices attached to the printer, then turn them off as well, and unplug any cables going into the printer.

- 1 Turn off the printer.
- 2 Unplug the power cord from the electrical outlet, and then from the printer.
- 3 Using a flat-head screwdriver, open the controller board access cover.

**Warning—Potential Damage:** Controller board electronic components are easily damaged by static electricity. Touch a metal surface on the printer before touching any controller board components or connectors.

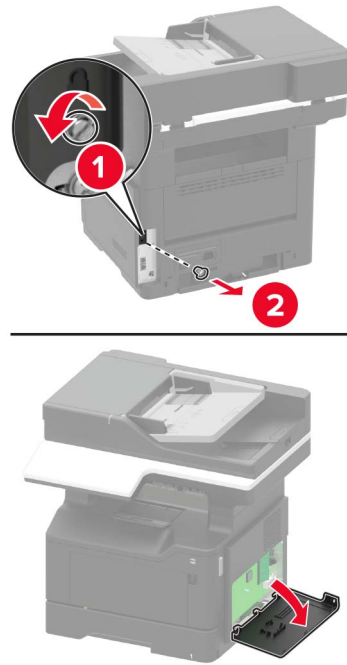

- 4 Close the access cover.
- 5 Connect the power cord to the printer, and then to the electrical outlet.
- 6 Turn on the printer.

## Installing an optional card

**⚠ CAUTION—SHOCK HAZARD:** To avoid the risk of electrical shock, if you are accessing the controller board or installing optional hardware or memory devices sometime after setting up the printer, then turn the printer off, and unplug the power cord from the electrical outlet before continuing. If you have any other devices attached to the printer, then turn them off as well, and unplug any cables going into the printer.

- 1 Turn off the printer.
- 2 Unplug the power cord from the electrical outlet, and then from the printer.
- 3 Open the controller board access cover.

**Warning—Potential Damage:** Controller board electronic components are easily damaged by static electricity. Touch a metal surface on the printer before touching any components or connectors.

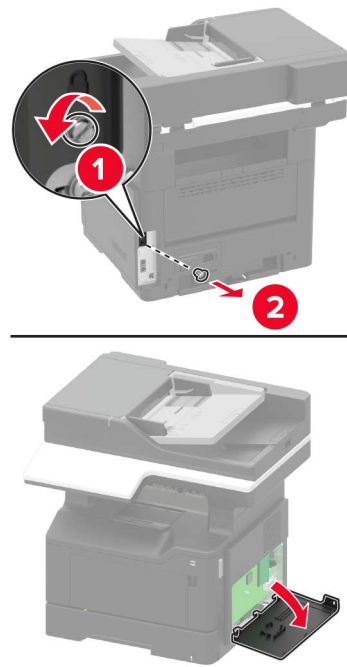

4 Unpack the optional card.

**Warning—Potential Damage:** Do not touch the connection points along the edge of the card.

5 Push the card firmly into place.

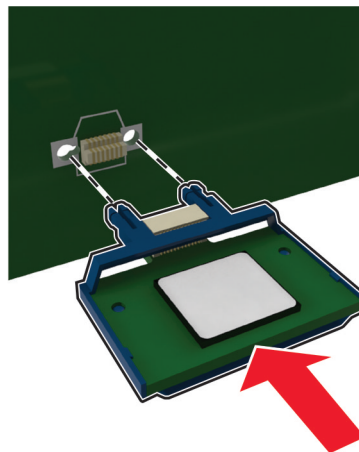

**Note:** The entire length of the connector on the card must touch and be flush against the controller board.

**Warning—Potential Damage:** Improper installation of the card may cause damage to the card and the controller board.

6 Close the access cover.

- 7 Connect the power cord to the printer, and then to the electrical outlet.

**⚠ CAUTION—POTENTIAL INJURY:** To avoid the risk of fire or electrical shock, connect the power cord to an appropriately rated and properly grounded electrical outlet that is near the product and easily accessible.

- 8 Turn on the printer.

## Installing a printer hard disk

**⚠ CAUTION—SHOCK HAZARD:** To avoid the risk of electrical shock, if you are accessing the controller board or installing optional hardware or memory devices sometime after setting up the printer, then turn the printer off, and unplug the power cord from the electrical outlet before continuing. If you have any other devices attached to the printer, then turn them off as well, and unplug any cables going into the printer.

- 1 Turn off the printer.
- 2 Unplug the power cord from the electrical outlet, and then from the printer.
- 3 Open the controller board access cover.

**Warning—Potential Damage:** Controller board electronic components are easily damaged by static electricity. Touch a metal surface on the printer before touching any controller board components or connectors.

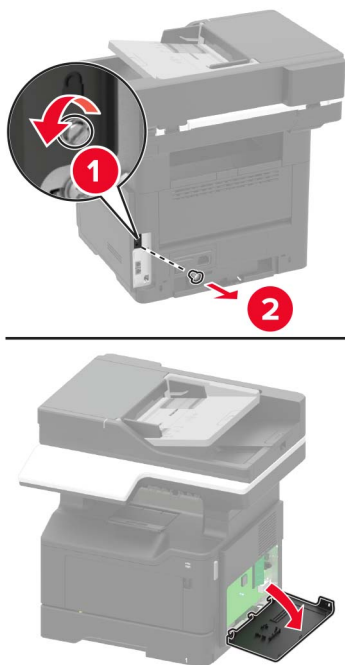

- 4 Unpack the hard disk.
- 5 Attach the hard disk to the controller board.

**Warning—Potential Damage:** Do not touch or press the center of the hard disk.

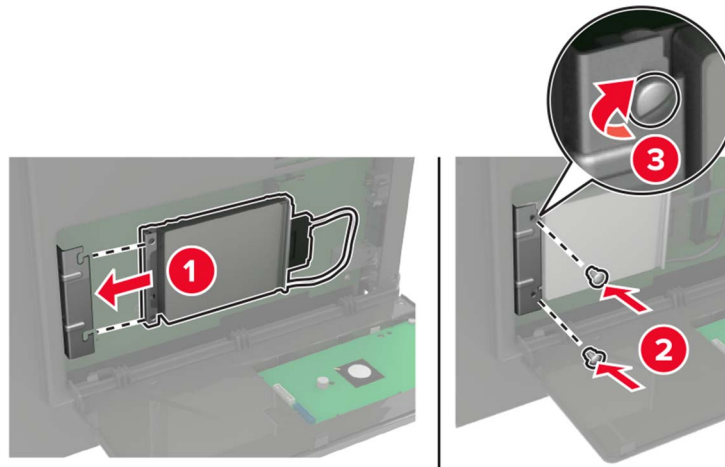

- 6 Attach the hard disk interface cable to the controller board.

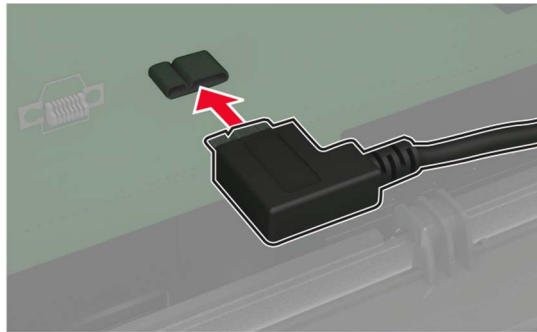

- 7 Close the access cover.  
8 Connect the power cord to the printer, and then to the electrical outlet.

**⚠ CAUTION—POTENTIAL INJURY:** To avoid the risk of fire or electrical shock, connect the power cord to an appropriately rated and properly grounded electrical outlet that is near the product and easily accessible.

- 9 Turn on the printer.

## Installing optional trays

**⚠ CAUTION—SHOCK HAZARD:** To avoid the risk of electrical shock, if you are accessing the controller board or installing optional hardware or memory devices sometime after setting up the printer, then turn the printer off, and unplug the power cord from the electrical outlet before continuing. If you have any other devices attached to the printer, then turn them off as well, and unplug any cables going into the printer.

- 1 Turn off the printer.  
2 Unplug the power cord from the electrical outlet, and then from the printer.

- 3 Unpack the optional tray, and then remove all packing material.

**Note:** If optional trays are already installed, then unlock them from the printer before lifting the printer. Do not try to lift the printer and trays at the same time.

- 4 Align the printer with the optional tray, and then lower the printer until it *clicks* into place.

 **CAUTION—POTENTIAL INJURY:** If the printer weight is greater than 18 kg (40 lb), then it requires two or more trained personnel to lift it safely.



- 5 Connect the power cord to the printer, and then to the electrical outlet.

 **CAUTION—POTENTIAL INJURY:** To avoid the risk of fire or electrical shock, connect the power cord to an appropriately rated and properly grounded electrical outlet that is near the product and easily accessible.

- 6 Turn on the printer.

Add the tray in the print driver to make it available for print jobs. For more information, see [“Adding available options in the print driver” on page 213](#).

## Software

### Supported operating systems

Using the *Drivers* CD, you can install the printer software on the following operating systems:

- Windows 8.1
- Windows Server 2012 R2
- Windows Server 2012
- Windows 7 SP1
- Windows Server 2008 R2 SP1
- Windows Server 2008 SP2
- Windows 10

- Windows Server 2016
- Mac OS X version 10.8 or later
- Red Hat Enterprise Linux 4 Desktop
- Red Hat Enterprise Linux 5 Desktop
- Red Hat Enterprise Linux 6 Desktop
- Red Hat Enterprise Linux 4 server
- Red Hat Enterprise Linux 5 server
- Red Hat Enterprise Linux 6 server
- SUSE Linux Enterprise Desktop 9
- SUSE Linux Enterprise Desktop 10
- SUSE Linux Enterprise Desktop 11
- SUSE Linux Enterprise Server 9
- SUSE Linux Enterprise Server 10
- SUSE Linux Enterprise Server 11

**Note:** For Windows operating systems, the print drivers and utilities are supported in both 32- and 64-bit versions.

## Installing the printer driver

### For Windows users

- 1 Insert the *Drivers* CD in the CD/DVD drive of your PC.
- 2 Follow the instructions on the computer screen.
- 3 Click **Printer Install**, and then follow the instructions on the computer screen.

**Note:** Obtain the printer IP address from the TCP/IP section in the Network/Ports menu.

### For Macintosh users

- 1 Insert the *Drivers* CD in the CD/DVD drive of your Macintosh.
- 2 Open the folder on the CD-ROM that contains the desired printer driver.
  - Select the folder according to the printer driver, operating system, and language to be used.
  - Navigate to:  
**Driver > MacOSX > OS\_10\_8\_x**
- 3 Copy the driver file onto the desktop according to the Mac OS X version.
  - Mac OS 10.8 or later: XXXX\_108\_1012.pkg
  - “XXXX” indicates the model name.
  - The driver folder varies depending on the required size. Select the file according to your environment.  
To mainly use the metric-based paper size such as A4 size: “WW\_A4” folder.  
To mainly use the inch-based paper size such as 8 1/2 x 11: “WW\_Letter” folder.
- 4 Double-click the file copied onto the desktop.  
The printer driver installer starts.



- 5** Click **Continue**, following the instructions on the pages that follow until the **Install** page appears.
- 6** Click **Install**.
  - When the name and password prompt appears during the procedure, enter the Administrator name and password.
- 7** Click **Close**.

This completes the installation process of the printer driver. Then, add the printer to the computer.
- 8** Select **System Preferences...** in the Apple menu.
- 9** Click the Printers & Scanners icon.
  - In Mac OS X 10.8, click the Print & Scan icon.
- 10** Click **+**.
  - If a target printer name is found in the list displayed by clicking **+**, select it. When a printer driver is selected automatically, the printer addition is completed. If a target printer name is not found, select **Add Other Printer or Scanner...** or **Add Printer or Scanner...**, and go to Step 11.
- 11** Click **Default**.
  - If no printers are detected, restart this machine.
- 12** From the Name list, select the desired printer for a Bonjour connection.

The printer driver for the selected printer is displayed in Use:.

  - When the printer driver is displayed, go to Step 14.
  - When the printer driver is not correctly displayed, go to Step 13.
- 13** Manually select the printer driver.
  - In Mac OS X 10.9 or later, select **Select Software...** from Use:, then click the driver of the desired printer from the list that is displayed in another window.
  - In Mac OS X 10.8, select **Select Printer Software...** from Use:, then click the driver of the desired printer from the list that is displayed in another window.
- 14** Click **Add**.
- 15** Click **OK**.

This completes the addition process of the printer.

## Adding available options in the print driver

### For Windows users

- 1** Open the printers folder.
- 2** Select the printer that needs update, and then do either of the following:
  - For Windows 7 or later, select **Printer properties**.
- 3** Navigate to the Configure tab, and then select **Acquire Device Information**.
- 4** Apply the changes.

## For Macintosh users

- 1 From System Preferences in the Apple menu, navigate to your printer, and then select **Options & Supplies**.
- 2 Navigate to the list of hardware options, and then add any installed options.
- 3 Apply the changes.

## Firmware

### Exporting or importing a configuration file

You can export the configuration settings of your printer into a text file, and then import the file to apply the settings to other printers.

- 1 Open a web browser, and then type the printer IP address in the address field.

**Notes:**

- View the printer IP address on the printer home screen. The IP address appears as four sets of numbers separated by periods, such as 123.123.123.123.
- If you are using a proxy server, then temporarily disable it to load the web page correctly.

- 2 From the Embedded Web Server, click **Export Configuration** or **Import Configuration**.
- 3 Follow the instructions on the screen.

### Updating firmware

Some applications require a minimum device firmware level to operate correctly.

For more information on updating the device firmware, contact your sales representative.

- 1 From the Embedded Web Server, click **Settings > Device > Update Firmware**.
- 2 Browse to locate the required flash file.
- 3 Apply the changes.

# Notices

## Copyright notice

This document may not be copied, in whole or part, nor transferred to any other media or language, without written permission of KONICA MINOLTA, INC.

## Edition notice

User's Guide may not be reproduced in part or in full without permission.

KONICA MINOLTA, INC. will not be held liable for any incidents caused by using this printing system or User's Guide.

Information included in User's Guide is subject to change without notice.

## Trademarks

KONICA MINOLTA, the KONICA MINOLTA logo, Giving Shape to Ideas, PageScope, and bizhub are registered trademarks or trademarks of KONICA MINOLTA, INC.

Google Cloud Print and Google Chrome are trademarks of Google Inc.

Macintosh, the Mac logo, and Safari are trademarks of Apple Inc.

Microsoft, Windows, and Internet Explorer are either registered trademarks or trademarks of the Microsoft group of companies in the United States and other countries.

Mopria®, the Mopria® logo, and the Mopria® Alliance logo are registered trademarks and service marks of Mopria Alliance, Inc. in the United States and other countries. Unauthorized use is strictly prohibited.

PCL® is a registered trademark of the Hewlett-Packard Company. PCL is Hewlett-Packard Company's designation of a set of printer commands (language) and functions included in its printer products. This printer is intended to be compatible with the PCL language. This means the printer recognizes PCL commands used in various application programs, and that the printer emulates the functions corresponding to the commands.

PostScript is a registered trademark of Adobe Systems Incorporated in the United States and/or other countries.

All other trademarks are the property of their respective owners.

AirPrint and the AirPrint logo are trademarks of Apple, Inc.

## SOFTWARE END USER LICENSE AGREEMENT

PLEASE READ CAREFULLY THE LICENSE AGREEMENT BELOW BEFORE OPENING THE PACKAGE OF THIS SOFTWARE ("SOFTWARE"), DOWNLOADING, INSTALLING OR USING THE SOFTWARE. OPENING THE PACKAGE, OR DOWNLOADING, INSTALLING OR USING THE SOFTWARE SHALL BE DEEMED YOUR LAWFUL ACCEPTANCE OF THE TERMS AND CONDITIONS BELOW. IF YOU DO NOT AGREE TO THEM, DO NOT DOWNLOAD, INSTALL, USE THE SOFTWARE, NOR OPEN THE PACKAGE.

### 1 COPYRIGHT AND INTELLECTUAL PROPERTY RIGHTS

This is a license agreement and not an agreement for sale. KONICA MINOLTA, INC. ("KONICA MINOLTA") owns, or has been licensed from other owners ("KONICA MINOLTA Licensor"), copyrights and other intellectual property rights of the Software, and any and all rights and title to the Software and any copy made from it are retained by KONICA MINOLTA or KONICA MINOLTA Licensor. In no event, this Agreement shall be deemed to assign any copyright and/or any intellectual property rights of the Software from KONICA MINOLTA or KONICA MINOLTA Licensor to you. The Software is protected by copyright laws and international treaty provisions.

## **2 LICENSE**

KONICA MINOLTA hereby grants to you a non-exclusive and limited license, and you may:

- (i) install and use the Software only on your computer(s) connected with a product for which this Software is designed;
- (ii) allow users of the computers described above to use the Software, provided that you assure that all such users comply with the terms of this Agreement;
- (iii) use the Software only for your own customary business or personal purpose;
- (iv) make one copy of the Software only for backup purpose in the support of the normal and intended use of the Software;
- (v) transfer the Software to other party by transferring a copy of this Agreement and all documentation along with the Software, provided that (a) you must, at the same time, either transfer to such other party or destroy all your other copies of the Software, (b) such transfer of possession terminates your license from KONICA MINOLTA, and (c) you must assure that such other party has agreed to accept the terms and conditions of this Agreement. If such other party does not accept such terms and conditions then you shall not transfer any copy of the Software.

## **3 RESTRICTIONS**

(1) You shall not without the written consent of KONICA MINOLTA:

- (i) use, copy, modify, merge or transfer copies of the Software except as provided herein;
- (ii) reverse engineer, reverse assemble, reverse compile or any other way analyze the Software;
- (iii) sublicense, rent, lease or distribute the Software or any copy thereof; or
- (iv) remove, use, or alter any trademark, logo, copyright or other proprietary notices, legends, symbols or labels in the Software.

(2) You agree that you will not export the Software in any form in violation of any applicable laws and regulations regarding export control of any country.

## **4 DISCLAIMER OF WARRANTIES**

(1) If the Software is furnished on CD-ROM(s) or other tangible object that is used for storage of digital data (hereinafter collectively "Storage Medium"), KONICA MINOLTA warrants the Storage Medium to be free from the defects in material and workmanship under normal use, for a period of ninety (90) days from the date of delivery to you. WITH THE EXCEPTION OF THE FOREGOING EXPRESS WARRANTIES APPLICABLE TO STORAGE MEDIUM ONLY, THE SOFTWARE IS PROVIDED TO YOU "AS IS" WITHOUT ANY WARRANTIES WHATSOEVER. KONICA MINOLTA, ITS AFFILIATE COMPANIES AND KONICA MINOLTA LICENSOR DISCLAIM ALL WARRANTIES WITH REGARD TO THE SOFTWARE, EXPRESS OR IMPLIED, INCLUDING, WITHOUT LIMITATION, IMPLIED WARRANTIES OF MERCHANTABILITY, FITNESS FOR A PARTICULAR PURPOSE AND NON-INFRINGEMENT OF THIRD PARTY RIGHTS.

(2) IN NO EVENT WILL KONICA MINOLTA, ITS AFFILIATE COMPANIES NOR KONICA MINOLTA LICENSOR BE LIABLE FOR ANY LOST PROFITS, LOST DATA, OR ANY OTHER INDIRECT, SPECIAL, PUNITIVE, INCIDENTAL OR CONSEQUENTIAL DAMAGES THAT RESULT FROM USE OR INABILITY TO USE THE SOFTWARE INCLUDING WITHOUT LIMITATION, DAMAGES FOR LOSS OF GOODWILL, COMPUTER FAILURE OR MALFUNCTION OR ANY AND ALL OTHER COMMERCIAL OR OTHER DAMAGES OR LOSSES, EVEN IF KONICA MINOLTA, ITS AFFILIATE COMPANIES OR KONICA MINOLTA LICENSOR HAS BEEN

ADVISED OF THE POSSIBILITY OF SUCH DAMAGES OR FOR ANY CLAIM BY YOU BASED ON A THIRD PARTY CLAIM.

(3) The disclaimer of warranty hereunder does not affect your statutory rights. In case of the disclaimer is not allowed by applicable law, the disclaimer shall only apply to you to the maximum extent permitted by the law.

## **5 TERMINATION**

You may terminate this license at any time by destroying the Software and all your copies of it. This Agreement shall also terminate if you fail to comply with any terms hereof. Upon such termination, you must immediately destroy all copies of the Software in your possession.

## **6 GOVERNING LAW**

This Agreement shall be governed by the laws of Japan.

## **7 SEVERABILITY**

In the event that any part or parts of this agreement shall be held illegal or null and void by any court or administrative body of competent jurisdiction, such determination shall not effect the remaining parts of this agreement and they shall remain in full force and effect as if such part or parts determined illegal or void had not been included.

## **8 NOTICE TO US GOVERNMENT END USERS**

The Software is a "commercial item," as that term is defined at 48 C.F.R. 2.101 (October 1995), consisting of "commercial computer software" and "commercial computer software documentation," as such terms are used in 48 C.F.R. 12.212 (September 1995). Consistent with 48 C.F.R. 12.212 and 48 C.F.R. 227.7202-1 through 227.7202-4 (June 1995), all U.S. Government End Users shall acquire the Software with only those rights set forth herein.

YOU ACKNOWLEDGE THAT YOU HAVE READ THIS AGREEMENT, UNDERSTAND IT, AND AGREE TO BE BOUND BY ITS TERMS AND CONDITIONS. NEITHER PARTY SHALL BE BOUND BY ANY OTHER STATEMENTS OR REPRESENTATIONS THAT ARE INCONSISTENT WITH THE TERMS AND CONDITIONS OF THIS AGREEMENT. NO AMENDMENT TO THIS AGREEMENT IS EFFECTIVE UNLESS WRITTEN AND SIGNED BY PROPERLY AUTHORIZED REPRESENTATIVES OF EACH PARTY. BY OPENING THE PACKAGE, DOWNLOADING, INSTALLING OR USING THE SOFTWARE YOU AGREE TO ACCEPT THE TERMS OF THIS AGREEMENT.

## **FIRMWARE UPDATES**

FIRMWARE UPDATES MAY MODIFY PRINTER SETTINGS AND CAUSE COUNTERFEIT AND/OR UNAUTHORIZED PRODUCTS, SUPPLIES, PARTS, MATERIALS (SUCH AS TONERS AND INKS), SOFTWARE, OR INTERFACES TO STOP WORKING. AUTHORIZED USE OF GENUINE PRODUCTS WILL NOT BE IMPACTED.

## **PRINTER AGREEMENT**

Please read before opening: Opening this package, installing the printing device software, or using the products inside confirms your acceptance of these contract terms: This printer is designed to work only with genuine KONICA MINOLTA, INC. supplies and you agree to only use genuine KONICA MINOLTA, INC. supplies with this printer. The installed supplies inside the printer are subject to a restriction that they be used only once and returned only to KONICA MINOLTA, INC. for remanufacturing or recycling. Supplies without this single-use term are available at [konicaminolta.com](http://konicaminolta.com) and may be remanufactured by you, or a third-party, as the only supplies alternatives to be used with the printer.

## SUPPLIES AGREEMENT

Please read before opening: By opening this package, you accept these contract terms. The supplies inside: (1) are sold at a special price contingent upon your agreement to use the supplies only once and return the supplies only to KONICA MINOLTA, INC. for remanufacturing or recycling after using them; and (2) will stop working after reaching end of the rated life established by KONICA MINOLTA, INC. (a variable amount of toner may remain when replacement is required). Supplies without this single-use term are available at [konicaminolta.com](http://konicaminolta.com). If you do not accept these terms, return the unopened supplies to the point of purchase.

## End User License Agreement

Suppliers of Licensor shall be deemed third party beneficiaries of this License.

### MICROSOFT CORPORATION NOTICES

- 1 This product may incorporate intellectual property owned by Microsoft Corporation. The terms and conditions upon which Microsoft is licensing such intellectual property may be found at <http://go.microsoft.com/fwlink/?LinkId=52369>.
- 2 This product is based on Microsoft Print Schema technology. You may find the terms and conditions upon which Microsoft is licensing such intellectual property at <http://go.microsoft.com/fwlink/?LinkId=83288>.

## Licensing notices

All licensing notices associated with this product can be viewed from the program folder.

## Noise emission levels

The following measurements were made in accordance with ISO 7779 and reported in conformance with ISO 9296.

**Note:** Some modes may not apply to your product.

1-meter average sound pressure, dBA	
Printing	56
Scanning	56
Copying	56
Ready	0

## Waste from Electrical and Electronic Equipment (WEEE) directive



The WEEE logo signifies specific recycling programs and procedures for electronic products in countries of the European Union. We encourage the recycling of our products.

## India E-Waste notice

This product complies with the India E-Waste (Management and Handling) Rules, 2011, which prohibit use of lead, mercury, hexavalent chromium, polybrominated biphenyls, or polybrominated diphenyl ethers in concentrations exceeding 0.1% by weight and 0.01% by weight for cadmium, except for the exemption set in Schedule II of the Rules.

## Product disposal

Do not dispose of the printer or supplies in the same manner as normal household waste. Consult your local authorities for disposal and recycling options.

## Static sensitivity notice



This symbol identifies static-sensitive parts. Do not touch the areas near these symbols without first touching a metal surface in an area away from the symbol.

## Temperature information

Ambient operating temperature	10 to 32°C (50 to 90°F)
Shipping temperature	-20 to 40°C (-4 to 104°F)
Storage temperature and relative humidity	0 to 40°C (32 to 104°F) 8 to 80% RH

## Power consumption

### Product power consumption

The following table documents the power consumption characteristics of the product.

**Note:** Some modes may not apply to your product.

Mode	Description	Power consumption (Watts)
Printing	The product is generating hard-copy output from electronic inputs.	One-sided: 620; Two-sided: 385
Copy	The product is generating hard-copy output from hard-copy original documents.	630
Scan	The product is scanning hard-copy documents.	20
Ready	The product is waiting for a print job.	14.5
Sleep Mode	The product is in a high-level energy-saving mode.	2.6
Hibernate	The product is in a low-level energy-saving mode.	0.1
Off	The product is plugged into an electrical outlet, but the power switch is turned off.	0.1

The power consumption levels listed in the previous table represent time-averaged measurements. Instantaneous power draws may be substantially higher than the average.

### Sleep Mode

This product is designed with an energy-saving mode called *Sleep Mode*. The Sleep Mode saves energy by lowering power consumption during extended periods of inactivity. The Sleep Mode is automatically engaged after this product is not used for a specified period of time, called the *Sleep Mode Timeout*.

Factory default Sleep Mode Timeout for this product (in minutes):	15
---	----

By using the configuration menus, the Sleep Mode Timeout can be modified between 1 minute and 120 minutes. Setting the Sleep Mode Timeout to a low value reduces energy consumption, but may increase the response time of the product. Setting the Sleep Mode Timeout to a high value maintains a fast response, but uses more energy.

### Hibernate Mode

This product is designed with an ultra-low power operating mode called *Hibernate mode*. When operating in Hibernate Mode, all other systems and devices are powered down safely.

The Hibernate mode can be entered in any of the following methods:

- Using the Hibernate Timeout
- Using the Schedule Power modes

Factory default Hibernate Timeout for this product in all countries or regions	3 days
--	--------



The amount of time the printer waits after a job is printed before it enters Hibernate mode can be modified between one hour and one month.

### **Off mode**

If this product has an off mode which still consumes a small amount of power, then to completely stop product power consumption, disconnect the power supply cord from the electrical outlet.

### **Total energy usage**

It is sometimes helpful to calculate the total product energy usage. Since power consumption claims are provided in power units of Watts, the power consumption should be multiplied by the time the product spends in each mode in order to calculate energy usage. The total product energy usage is the sum of each mode's energy usage.

## **Patent acknowledgment**

The use of this product or service is subject to the reasonable, non-discriminatory terms in the Intellectual Property Rights (IPR) Disclosure of Certicom Corp. at the IETF for Elliptic Curve Cryptography (ECC) Cipher Suites for Transport Layer Security (TLS) implemented in the product or service.

The use of this product or service is subject to the reasonable, non-discriminatory terms in the Intellectual Property Rights (IPR) Disclosure of Certicom Corp. at the IETF for TLS Elliptic Curve Cipher Suites with SHA-256/382 and AES Galois Counter Mode (GCM) implemented in the product or service.

The use of this product or service is subject to the reasonable, non-discriminatory terms in the Intellectual Property Rights (IPR) Disclosure of Certicom Corp. at the IETF for TLS Suite B Profile for Transport Layer Security (TLS) implemented in the product or service.

The use of this product or service is subject to the reasonable, non-discriminatory terms in the Intellectual Property Rights (IPR) Disclosure of Certicom Corp. at the IETF for Addition of the Camellia Cipher Suites to Transport Layer Security (TLS) implemented in the product or service.

The use of certain patents in this product or service is subject to the reasonable, non-discriminatory terms in the Intellectual Property Rights (IPR) Disclosure of Certicom Corp. at the IETF for AES-CCM ECC Cipher Suites for TLS implemented in the product or service.

The use of this product or service is subject to the reasonable, non-discriminatory terms in the Intellectual Property Rights (IPR) Disclosure of Certicom Corp. at the IETF for IKE and IKEv2 Authentication Using the Elliptic Curve Digital Signature Algorithm (ECDSA) implemented in the product or service.

The use of this product or service is subject to the reasonable, non-discriminatory terms in the Intellectual Property Rights (IPR) Disclosure of Certicom Corp. at the IETF for Suite B Cryptographic Suites for IPsec implemented in the product or service.

The use of this product or service is subject to the reasonable, non-discriminatory terms in the Intellectual Property Rights (IPR) Disclosure of Certicom Corp. at the IETF for Algorithms for Internet Key Exchange version 1 (IKEv1) implemented in the product or service.

# Index

## A

- About this Printer menu 63
- accessing the controller board 206
- adapter plug 45
- adding contacts 17
- adding groups 17
- adding options in the print driver 213
- ADF registration
  - adjusting 205
- adjusting ADF registration 205
- adjusting scanner registration 205
- adjusting the brightness
  - printer display 151
- adjusting the brightness of the printer display 151
- adjusting toner darkness 197
- AirPrint
  - using 26
- answering machine
  - setting up 35
- attaching cables 11
- avoiding paper jams 153

## B

- blank pages 173
- blocking junk faxes 50

## C

- cables
  - Ethernet 11
  - USB 11
- can send but not receive faxes 200
- canceling a print job
  - from the computer 29
  - from the printer control panel 29
- cannot open Embedded Web Server 164
- changing the wallpaper 16
- checking the status of parts and supplies 138
- cleaning
  - exterior of the printer 135

- interior of the printer 135
- cleaning the printer 135
- cleaning the scanner 129, 136
- collated printing does not work 167
- collating copies 32
- confidential print jobs 29
- configuration information
  - wireless network 133
- configuring daylight saving time 48
- configuring e-mail settings 33
- configuring supply notifications 139
- connecting printer to distinctive ring service 47
- connecting to a wireless network
  - using PIN method 134
  - using Push Button method 134
- conserving supplies 152
- contacting customer support 205
- contacts
  - adding 17
  - deleting 18
  - editing 17
- control panel
  - using 13
- controller board
  - accessing 206
- copy troubleshooting
  - partial copies of documents or photos 202
  - poor copy quality 202
  - scanner does not respond 204
  - scanner unit does not close 204
- copying
  - creating shortcuts 32
  - on both sides of the paper 31
- copying different paper sizes 31
- copying from
  - selected tray 31
- copying multiple pages
  - onto a single sheet 32
- copying on letterhead 31
- copying photos 31

- creating shortcuts
  - e-mail 34
  - fax destination 49
- crooked print 185
- customer support
  - contacting 205
- customizing the display 16

## D

- date and time
  - fax settings 48
- daylight saving time, configuring 48
- deleting contacts 18
- deleting groups 18
- different paper sizes, copying 31
- digital subscriber line (DSL)
  - fax setup 40
- digital telephone service
  - fax setup 43
- directory list
  - printing 29
- Display Customization
  - using 16
- disposing of printer hard disk 131
- distinctive ring service, fax
  - connecting to 47
- documents, printing
  - from a mobile device 26
- dots on print 183
- DSL filter 40

## E

- Eco-Mode
  - configuring 151
- editing contacts 17
- editing groups 17
- Embedded Web Server
  - using 14
- emission notices 218
- enabling the USB port 165
- encrypting the printer hard disk 131
- enlarging copies 32
- environmental settings 151
- erasing printer hard disk memory 130
- Ethernet menu 110

- Ethernet network
  - preparing to set up for Ethernet
  - printing 133
- Ethernet port 11
- Ethernet setup
  - preparing for an 133
- exporting a configuration file
  - using the Embedded Web Server 214
- exporting compressed logs 63
- exporting configuration file 63
- EXT port 11
- e-mail
  - creating shortcuts 34
  - setting up 33
- e-mailing
  - configuring e-mail settings 33
  - using a shortcut number 33
  - using the address book 33
  - using the printer 33

## F

- fax log
  - viewing 49
- fax port 11
- fax resolution
  - changing 49
- fax setup
  - country- or region-specific 45
  - digital telephone service 43
  - DSL connection 40
  - standard telephone line connection 35
  - VoIP 41
- fax troubleshooting
  - cannot receive faxes 200
  - cannot send faxes 200
  - cannot send or receive faxes 198
  - received fax has poor print quality 200
- faxing
  - adjusting darkness 49
  - blocking junk faxes 50
  - changing resolution 49
  - creating shortcuts 49
  - fax setup 35
  - forwarding faxes 50
  - holding faxes 50
  - setting the date and time 48
  - viewing a fax log 49

- firmware
  - update 214
- flash drive
  - printing from 27
  - scanning to 51
- Flash Drive Print menu 106
- folder paper 176
- font sample list
  - printing 29
- forwarding faxes 50
- FTP address
  - creating shortcuts 51
- FTP server, scanning to
  - using the control panel 51

## G

- Google Cloud Print
  - using 26
- groups
  - adding 17
  - deleting 18
  - editing 17

## H

- hardware options
  - trays 210
- held jobs 29
- Help menu 128
- Hibernate mode
  - configuring 151
- holding faxes 50
- home screen
  - customizing 16
  - showing icons 16
  - using 15
- HTTP/FTP Settings menu 116

## I

- icons on the home screen
  - showing 16
- identifying jam locations 154
- imaging unit
  - ordering 138
  - replacing 141
- importing a configuration file
  - using the Embedded Web Server 214
- indicator light
  - understanding the status 13
- installing a printer hard disk 209
- installing an optional card 207

- installing options
  - printer hard disk 209
- installing the printer driver 212
- internal options
  - firmware card 206
  - installing 207
  - internal solutions port 206
  - memory card 206
  - printer hard disk 206, 209
- internal options, adding
  - print driver 213
- IPSec menu 114

## J

- jams
  - avoiding 153
- jams, clearing
  - in the automatic document feeder 162
  - in the duplex unit 160
  - in the front door 155
  - in the multipurpose feeder 161
  - in the standard bin 159
  - trays 161

## K

- keyboard on the display
  - using 14

## L

- letterhead
  - copying on 31
- line filter 40
- LINE port 11
- linking trays 22
- loading
  - multipurpose feeder 21
- loading envelopes
  - in the multipurpose feeder 21
- loading trays 19
- locating paper jams 154
- locating the security slot 130

## M

- making copies 31
- memory
  - types installed on printer 131
- menu
  - 802.1x 115
  - Accessibility 59
  - Confidential Print Setup 124

- Configuration Menu 59
- Copy Defaults 74
- Custom Scan Sizes 73
- Device 127
- Erase Temporary Data Files 126
- Ethernet 110
- E-mail Defaults 92
- E-mail Setup 90
- Fax 128
  - Fax Cover Page 86
  - Fax Log Settings 86
  - Fax Mode 78
  - Fax Receive Settings 83
  - Fax Send Settings 79
  - Fax Server E-mail Settings 88
  - Fax Server Scan Settings 89
  - Flash Drive Print 106
  - Flash Drive Scan 102
  - FTP Defaults 97
  - General Fax Settings 78, 87
  - Google Cloud Print 118
  - HTML 70
  - HTTP/FTP Settings 116
  - Image 71
  - IPSec 114
  - Job Accounting 66
  - Layout 63
  - Local Accounts 121
  - Login Restrictions 124
  - LPD Configuration 116
  - Manage Permissions 119
  - Media Types 74
  - Menu Settings Page 127
  - Miscellaneous 126
  - Mobile Services
    - Management 126
  - Network 128
  - Network Overview 107
  - Notifications 56
  - Out of Service Erase 62
  - PCL 69
  - PDF 68
  - PostScript 68
  - Power Management 58
  - Preferences 54
  - Print 128
  - Quality 65
  - Remote Operator Panel 56
  - Security Audit Log 122
  - Setup 65
  - Shortcuts 128
  - SNMP 113
- Solutions LDAP Settings 126
- Speaker Settings 87
- TCP/IP 111
- ThinPrint 117
- Tray Configuration 72
- Troubleshooting 129
- Universal Setup 73
- USB 117
- Visible Home Screen Icons 63
- Web Link Setup 97
- Wi-Fi Direct 118
- XPS 67
- Menu map 53
- menu settings page
  - printing 14
- menus
  - About this Printer 63
  - Disk Encryption 125
  - Restore Factory Defaults 59
  - Schedule USB Devices 121
  - Wireless 108
- mobile device
  - printing from 26
- Mopria Print Service
  - using 26
- mottled print 183
- moving the printer 9, 150
- multipurpose feeder
  - loading 21
- N**
- Network Overview menu 107
- Network Setup Page
  - printing 14
- network setup page
  - printing 165
- noise emission levels 218
- non-volatile memory 131
  - erasing 130
- notices 218, 219, 220, 221
- O**
- optional card
  - installing 207
- ordering
  - imaging unit 138
  - toner cartridge 138
- P**
- paper
  - Universal size setting 19
  - paper jam in the automatic document feeder 162
  - paper jam in the duplex unit 160
  - paper jam in the front door 155
  - paper jam in the multipurpose feeder 161
  - paper jam in the rear door 158
  - paper jam in trays 161
  - paper jam, clearing
    - in the automatic document feeder 162
    - in the duplex unit 160
    - in the front door 155
    - in the multipurpose feeder 161
    - in the rear door 158
    - trays 161
  - paper jams
    - avoiding 153
  - paper jams, clearing
    - in the standard bin 159
  - paper size
    - setting 19
  - paper type
    - setting 19
  - parts status
    - checking 138
  - personal identification number method 134
  - phone splitter 41
  - photos
    - copying 31
  - pick roller assembly
    - replacing 146
  - pick tires
    - replacing 144
  - placing separator sheets
    - between copies
      - copying 32
  - power save modes
    - configuring 151
  - preparing to set up the printer on an Ethernet network 133
  - print job
    - canceling from the computer 29
    - canceling from the printer control panel 29
  - print quality troubleshooting
    - blank or white pages 173
    - crooked or skewed print 185
    - dark print 174

- fine lines are not printed
    - correctly 176
  - folded or wrinkled paper 176
  - gray background on prints 177
  - horizontal light bands 179
  - light print 181
  - mottled print and dots 183
  - paper curl 184
  - repeating defects 186
  - solid black pages 187
  - text or images cut off 188
  - toner easily rubs off 190
  - vertical dark bands 190
  - vertical dark lines or streaks 192
  - vertical dark streaks with print missing 193
  - vertical light bands 194
  - vertical white lines 195
  - print troubleshooting
    - confidential and other held documents do not print 169
    - envelope seals when printing 167
    - incorrect margins 180
    - jammed pages are not reprinted 169
    - job prints from the wrong tray 197
    - job prints on the wrong paper 197
    - paper frequently jams 168
    - print jobs do not print 172
    - slow printing 170
    - tray linking does not work 167
    - unable to read flash drive 165
  - printer
    - minimum clearances 9
    - selecting a location 9
    - shipping 151
  - printer configurations 10
  - printer display
    - adjusting the brightness 151
  - printer hard disk
    - disposing of 131
    - encrypting 131
  - printer hard disk encryption 131
  - printer hard disk memory
    - erasing 130
  - printer is not responding 196
  - printer menus 53, 63
  - printer options troubleshooting
    - internal option is not detected 166
  - printer ports 11
  - printer settings
    - restoring to factory defaults 131
  - printer status 13
  - printing
    - directory list 29
    - font sample list 29
    - from a computer 26
    - from a flash drive 27
    - from a mobile device 26
    - menu settings page 14
    - Network Setup Page 14
    - network setup page 165
    - quality test pages 129
  - printing a directory list 29
  - printing a font sample list 29
  - printing a menu settings page 14
  - printing a network setup page 165
  - printing from a computer 26
  - printing from a flash drive 27
  - Push Button method 134
- R**
- reducing copies 32
  - repeat print jobs 29
  - replacing supplies
    - imaging unit 141
    - toner cartridge 139
  - replacing the pick roller assembly 146
  - replacing the pick tires 144
  - restoring factory default settings 131
  - RJ11 adapter 45
  - running a slideshow 16
- S**
- safety information 6, 7, 8
  - saving paper 32
  - saving toner 32
  - Scan to Computer
    - setting up 52
  - scan troubleshooting
    - cannot scan from a computer 201
    - partial copies of documents or photos 202
    - poor copy quality 202
    - scan job was not successful 203
  - scanner does not respond 204
  - scanner unit does not close 204
  - scanning freezes the computer 204
  - scanning takes too long 204
  - vertical dark streaks on output
    - when scanning from the ADF 202
  - scanner
    - cleaning 136
    - scanner registration
      - adjusting 205
    - scanning
      - to an FTP server 51
    - scanning quality problem 202
    - scanning to a computer 52
    - scanning to a flash drive 51
    - scanning to an FTP server
      - using the control panel 51
  - scheduling a fax 49
  - security slot
    - locating 130
  - selecting a location for the printer 9
  - sending a fax
    - scheduled 49
    - using the computer 48
    - using the control panel 48
  - sending an e-mail 33
  - setting the paper size 19
  - setting the paper type 19
  - setting the Universal paper size 19
  - setting up e-mail function 33
  - setting up fax
    - country- or region-specific 45
    - digital telephone service 43
    - DSL connection 40
    - standard telephone line connection 35
    - VoIP connection 41
  - setting up fax function 35
  - shipping the printer 151
  - shortcuts, creating
    - copy screen 32
    - FTP address 51
  - showing icons on the home screen 16

- skewed print 185
- sleep button light
  - understanding the status 13
- Sleep mode
  - configuring 151
- statement of volatility 131
- storing print jobs 29
- supplies
  - conserving 152
- supplies status
  - checking 138
- supplies, ordering
  - imaging unit 138
- supply notifications
  - configuring 139
- supported file types 28
- supported flash drives 28
- supported operating systems 211
- supported paper sizes 23
- supported paper types 25
- supported paper weights 25

## T

- toner cartridge
  - ordering 138
  - replacing 139
- toner darkness
  - adjusting 197
- trays
  - installing 210
  - linking 22
  - loading 19
  - unlinking 22
- troubleshooting
  - cannot open Embedded Web Server 164
  - printer is not responding 196
- troubleshooting, copy
  - partial copies of documents or photos 202
  - poor copy quality 202
  - scanner does not respond 204
  - scanner unit does not close 204
- troubleshooting, fax
  - cannot send faxes 200
  - cannot send or receive faxes 198
  - received fax has poor print quality 200

- troubleshooting, print
  - collated printing does not work 167
  - confidential and other held documents do not print 169
  - envelope seals when printing 167
  - incorrect margins 180
  - jammed pages are not reprinted 169
  - job prints from the wrong tray 197
  - job prints on the wrong paper 197
  - paper frequently jams 168
  - print jobs do not print 172
  - slow printing 170
  - tray linking does not work 167
- troubleshooting, print quality
  - blank or white pages 173
  - crooked or skewed print 185
  - dark print 174
  - fine lines are not printed correctly 176
  - folded or wrinkled paper 176
  - gray background on prints 177
  - horizontal light bands 179
  - light print 181
  - mottled print and dots 183
  - paper curl 184
  - repeating defects 186
  - solid black pages 187
  - text or images cut off 188
  - toner easily rubs off 190
  - vertical dark bands 190
  - vertical dark lines or streaks 192
  - vertical dark streaks with print missing 193
  - vertical light bands 194
  - vertical white lines 195
- troubleshooting, printer options
  - internal option is not detected 166
- troubleshooting, scan
  - cannot scan from a computer 201
  - partial copies of documents or photos 202
  - poor copy quality 202
  - scan job was not successful 203

- scanner does not respond 204
- scanner unit does not close 204
- vertical dark streaks on output when scanning from the ADF 202
- two-sided copying 31

## U

- unable to read flash drive
  - troubleshooting, print 165
- Universal paper size
  - setting 19
- unlinking trays 22
- updating firmware
  - flash file 214
- USB port 11
  - enabling 165
- using Display Customization 16
- using genuine KONICA MINOLTA parts 138
- using genuine KONICA MINOLTA supplies 138
- using the ADF
  - copying 31
- using the control panel 13
- using the Embedded Web Server 14
- using the home screen 15
- using the keyboard on the display 14
- using the scanner glass
  - copying 31

## V

- verify print jobs 29
- vertical dark lines on prints 192
- vertical dark streaks on output when scanning from the ADF 202
- vertical streaks on prints 192
- viewing a fax log 49
- voice mail
  - setting up 35
- voice over Internet Protocol (VoIP)
  - fax setup 41
- VoIP adapter 41
- volatile memory 131
  - erasing 130

volatility  
statement of 131

## **W**

white lines 195  
white pages 173  
Wireless menu 108  
wireless network  
configuration information 133  
Wi-Fi Protected Setup 134  
Wi-Fi Protected Setup  
wireless network 134  
wrinkled paper 176