



KONICA MINOLTA

bizhub 306/266 **USER'S GUIDE**

✎ Copy





Table of contents

1 Introduction

1.1	Welcome	1-3
1.1.1	User's guides	1-3
1.1.2	User's Guide	1-3
1.2	Conventions used in this manual	1-4
1.2.1	Notations and symbols used in this manual	1-4
	Symbols used in this manual	1-4
	Procedural instruction.....	1-4
	Product and key names	1-5
	Notations of application names	1-5
1.2.2	Original and paper indications	1-6
	Original and paper sizes	1-6
	Original and paper indications	1-6

2 Before Using This Machine

2.1	Part names and their functions	2-3
2.2	Main Body	2-5
2.2.1	Exterior of the main unit.....	2-5
2.2.2	Interior of the main unit.....	2-7
2.2.3	Reverse Automatic Document Feeder (Option)/Automatic Duplex Unit.....	2-8
	Reverse Automatic Document Feeder	2-8
	Automatic Duplex Unit	2-8
2.2.4	Paper Feeder Unit (Option)	2-9
2.3	Control Panel.....	2-10
2.3.1	Name and function of each part on the control panel	2-10
2.3.2	Extended Operation Panel MK-750 (Option)	2-13
2.3.3	Display message.....	2-14
2.4	Power	2-19
2.4.1	Turning on the power	2-19
2.4.2	Turning off the power.....	2-19
2.4.3	Initial mode.....	2-19
2.4.4	Auto Panel Reset	2-20
2.4.5	Sleep mode.....	2-20
2.4.6	Auto shut time	2-20
2.4.7	Next Copy Job	2-20
2.5	Saving electricity.....	2-21
2.5.1	Setting sleep mode.....	2-21
2.5.2	Specifying the auto shut time	2-22

3 Before Making Copies

3.1	Paper	3-3
3.1.1	Confirm the Available Paper Types.....	3-3
3.1.2	Confirm the Available Paper Sizes.....	3-4
3.1.3	Precautions for using paper.....	3-4
3.2	Image copy/printing area	3-5
3.3	Storing paper	3-6
3.4	Loading paper	3-7
3.4.1	Loading paper into Tray1	3-7
3.4.2	Loading paper to Tray2/Tray3/Tray4/Tray5	3-8

3.5	Original	3-10
3.5.1	Using ADF	3-10
3.5.2	Original type.....	3-10
3.5.3	Precautions on originals.....	3-11
3.6	Loading the original	3-12
3.6.1	Loading the original into the ADF	3-12
3.6.2	Setting the original on the Original Glass.....	3-13
3.6.3	Loading the highly translucent or transparent original	3-14
3.6.4	Setting the book original.....	3-15
3.6.5	Setting originals of different sizes (Mixed Original).....	3-16

4 Making Copies

4.1	Copy	4-3
4.1.1	Basic copying method	4-3
4.1.2	Reducing or enlarging a standard size original to a different standard size.....	4-4
4.1.3	Specifying the image quality to fit the original	4-4
4.1.4	Specifying the density.....	4-5
4.1.5	Setting the original direction	4-6
4.2	Stopping, restarting, or erasing the copy job	4-7
4.3	Selecting the tray	4-8
4.3.1	Auto tray change function.....	4-8
4.3.2	Tray selection order by tray change function	4-9
4.4	Manually making copies	4-10
4.4.1	Paper type and number of sheets of paper available for the Bypass Tray.....	4-10
4.4.2	Adjusting the Bypass Tray	4-10
4.4.3	Loading plain paper into the Bypass Tray	4-11
4.4.4	Loading OHP transparencies into Bypass Tray	4-12
4.4.5	Loading envelopes into the Bypass Tray.....	4-12
4.4.6	Manually making copies (Bypass Tray).....	4-13
4.5	Making copies on various types of paper	4-15
4.5.1	Making copies on OHP transparencies	4-15
4.5.2	Making copies on custom size paper	4-16
4.5.3	Making copies on envelopes	4-18
4.6	Specifying the zoom ratio to copy the original	4-19
4.6.1	Zoom ratio setting type.....	4-19
4.6.2	Setting the auto zoom function.....	4-19
4.6.3	Setting the fixed zoom ratio	4-20
4.6.4	Setting the zoom ratio manually	4-20
4.6.5	Setting the X/Y variable zoom ratio	4-21
4.7	Changing copy density to copy the original	4-22
4.7.1	Setting the copy density	4-22



5 Making Copies in Advanced Manner

5.1	Finishing setting (sorting, grouping)	5-3
5.1.1	Finishing type	5-3
5.1.2	Setting finishing	5-5
5.2	Making 1-sided or 2-sided copy	5-6
5.3	Configuring 2in1 or 4in1 copy settings	5-8
5.4	Using the ID Copy	5-10
5.5	Making copies by entering the ID (Account) number	5-11
5.6	Setting book separation copy	5-12
5.6.1	Frame/Center erase type	5-13
5.7	Erasing a part of the original and making copies (Erase)	5-14
	Setting the erase	5-14
5.8	Erasing shadows outside the original to copy (Outer Erase)	5-15
5.9	Making copies with black and white reversed (Neg./Pos. Reverse)	5-17
5.10	Making copies with a binding margin	5-18
	Setting a binding margin	5-18
5.11	Making copies with a date and page number	5-19
5.12	Registering or recalling the copy settings	5-20
5.12.1	Registering the copy setting	5-20
5.12.2	Recalling the copy setting and making copies	5-21

6 Utility and Copy Settings

6.1	Utility	6-3
6.2	Machine Setting	6-4
6.2.1	Select Machine Setting	6-5
6.2.2	Changing the auto panel reset setting	6-5
6.2.3	Changing the sleep mode setting	6-6
6.2.4	Changing the auto shut time	6-6
6.2.5	Changing the image quality when using the ADF	6-7
6.2.6	Changing the image quality when using the Original Glass	6-7
6.2.7	Changing the density	6-8
6.2.8	Changing the LCD contrast	6-8
6.2.9	Changing key speed setting	6-9
6.2.10	Changing time interval between continuous key operations	6-10
6.2.11	Changing the language to be displayed on the Display	6-10
6.3	Tray Settings	6-11
6.3.1	Selecting tray settings	6-11
6.3.2	Setting the unit of the paper size	6-12
6.3.3	Configuring paper settings for Tray1	6-12
6.3.4	Configuring settings for Tray2 to Tray5	6-13
6.4	Registering a custom size	6-14
6.4.1	Registering a custom size	6-14
6.5	Drum Dry (Dew condensation removal)	6-16
6.6	Administrator Settings	6-17
6.6.1	Selecting the administrator setting	6-18
6.6.2	Changing the administrator number	6-18
6.6.3	Enabling a change of the auto shut time	6-19
6.6.4	Configuring setting so that sleep mode is not used	6-19
6.6.5	Configuring PWR CONS. SLEEP	6-19
6.6.6	Specifying ACCOUNT TRACK MODE	6-19
6.6.7	Registering ID (account)	6-20
6.6.8	Changing or deleting the ID (account)	6-20
6.6.9	Displaying or erasing the total counter by ID (account)	6-21
6.6.10	Erasing all total counters by ID (account)	6-22



6.7	COPY SETTING 1	6-23
6.7.1	Selecting COPY SETTING 1	6-24
6.7.2	Setting the tray priority.....	6-24
6.7.3	Specifying the quality priority.....	6-24
6.7.4	Specifying the density priority.....	6-25
6.7.5	Specifying the density level priority (Auto).....	6-25
6.7.6	Specifying the density level priority (Manual).....	6-26
6.7.7	Setting 2-sided printing	6-26
6.7.8	Setting the copy page margin.....	6-27
6.7.9	Setting the original page margin position	6-27
6.7.10	Setting the book binding position.....	6-28
6.7.11	Adjusting the page margin width	6-28
6.7.12	Setting the erase width	6-29
6.7.13	Setting the density of the original for OUTER ERASE	6-29
6.7.14	Setting a small size original.....	6-30
6.8	COPY SETTING 2	6-31
6.8.1	Selecting COPY SETTING 2	6-32
6.8.2	Setting the copy mode priority	6-32
6.8.3	Specifying the finishing priority	6-32
6.8.4	Specifying the alternate output.....	6-33
6.8.5	Setting 4in1 page copy order	6-33
6.8.6	Specifying the mixed original priority.....	6-34
6.8.7	Configure ORIG. DIRECTION setting.....	6-34
6.8.8	Configuring BOOK SEPARATION setting.....	6-35
6.8.9	Setting stamp printing.....	6-35
6.8.10	Setting the page number print format.....	6-36
6.8.11	Setting the date/time print format.....	6-36
6.9	CONFIRM MODE	6-37
6.9.1	Items you can confirm using the machine counter	6-37
6.9.2	Viewing the total counter	6-37
6.9.3	Printing reports	6-38
6.9.4	Printing reports	6-38

7 If you suspect a failure then do the following

7.1	If this copy is output	7-3
7.2	Major messages and troubleshooting	7-5
7.3	The copier does not function.	7-7

8 Others

8.1	Major specifications	8-3
8.1.1	bizhub 306/266	8-3
8.1.2	Reverse Automatic Document Feeder DF-625	8-5
8.1.3	Paper Feeder Unit PF-509	8-5
8.2	Daily maintenance	8-6
8.2.1	Housing.....	8-6
8.2.2	Original Glass.....	8-6
8.2.3	Slit Scan Glass.....	8-6
8.2.4	Original Pad	8-7
8.2.5	Control Panel	8-7

9 Index

9.1	Index by item	9-3
9.2	Index by button	9-6





Introduction

1 Introduction

1.1 Welcome

Thank you for purchasing this machine.

This User's Guide describes the functions, operating instructions, precautions for correct operation, and simple troubleshooting guidelines of this machine. In order to obtain maximum performance from this product and use it effectively, please read this User's Guide as necessary.

1.1.1 User's guides

User's guide CD/DVD manuals	Overview
[Quick Guide]	This manual describes operating procedures and the most frequently used functions to enable you to begin using this machine immediately.
[User's Guide Copy]	This manual describes details on copy mode operations and the settings of this machine. <ul style="list-style-type: none"> • Specifications of originals and copy paper • Copy function • Maintaining this machine • Troubleshooting
[User's Guide Fax]	This manual describes fax mode operations and settings. <ul style="list-style-type: none"> • G3 fax function • Internet Fax • PC-FAX
[User's Guide Print]	This manual describes details on printer functions. <ul style="list-style-type: none"> • Printer function • Setting the printer driver • USB Direct Print • Mobile Print
[User's Guide Scan]	This manual describes details on scan functions. <ul style="list-style-type: none"> • Scan Function • Setting the TWAIN/WIA scan driver • Network scan (E-mail TX, FTP TX, SMB TX, and mobile TX) • Scan to USB
[User's Guide Network Administrator]	This manual describes details on setting methods for each function using the network connection. <ul style="list-style-type: none"> • Network settings • Settings using Web Connection
[Trademarks/Copyrights]	This manual describes details on trademarks and copyrights. <ul style="list-style-type: none"> • Trademarks and copyrights

1.1.2 User's Guide

This User's Guide is intended for users ranging from those using this machine for the first time to administrators.

It describes basic operations, functions that enable more convenient operations, maintenance procedures, simple troubleshooting operations, and various setting methods of this machine.

Note that basic technical knowledge about the product is required to enable users to perform maintenance work or troubleshooting operations. Limit your maintenance and troubleshooting operations to the areas explained in this manual.

Should you experience any problems, please contact our service representative.

1.2 Conventions used in this manual

1.2.1 Notations and symbols used in this manual

Symbols are used in this manual to express various types of information.

The following describes each symbol related to correct and safe usage of this machine.

Symbols used in this manual

WARNING

- This symbol indicates that a failure to heed the instructions may lead to death or serious injury.
-

CAUTION

- This symbol indicates that a failure to heed the instructions may lead to mishandling that may cause injury or property damage.
-

NOTICE

This symbol indicates a risk that may result in damage to this machine or documents. Follow the instructions to avoid property damage.

Tips

This symbol indicates supplemental information of a topic as well as options required to use a function.

Note

This symbol indicates supplemental information of a topic.

Reference

This symbol indicates reference functions related to a topic.

Related setting

This shows the settings related to a particular topic for any user.

Related setting (for the administrator)

This shows the settings related to a topic only for administrators.

Procedural instruction

- ✓ This check mark indicates an option that is required in order to use conditions or functions that are prerequisite for a procedure.

1 This format number "1" represents the first step.

2 This format number represents the order of serial steps.

- This symbol indicates a supplementary explanation of a procedural instruction.

The operation procedures are described using illustrations.

→ This symbol indicates transition of the **Display** to access a desired menu item.

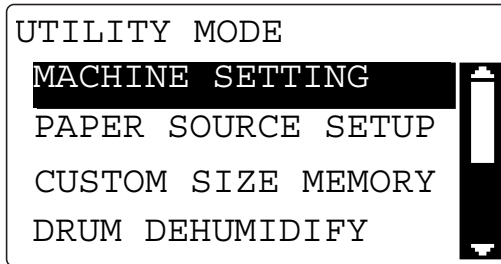

This symbol indicates a desired page.



Reference

This symbol indicates a reference.

View the reference as required.

Product and key names

Notations used in this manual	Description
[]	An item enclosed in brackets [] indicates a key name on the Display or computer screen, or the name of a user's guide.
Bold text	This presents a key name, part name, product name, or option name on the Control Panel .

Notations of application names

This manual describes application names as shown below.

Application name	Notations used in this manual
PageScope Web Connection	Web Connection
PageScope Mobile (for iPhone/iPad/Android)	Mobile (for iPhone/iPad/Android)

1.2.2 Original and paper indications

Original and paper sizes

The following explains the indication for originals and paper described in this manual.

When indicating the original or paper size, the Y side represents the width and the X side the length.

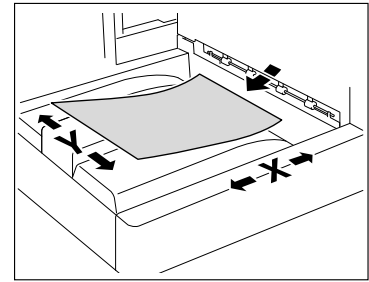

Original and paper indications

☐ indicates the paper size with the length (X) being longer than the width (Y).

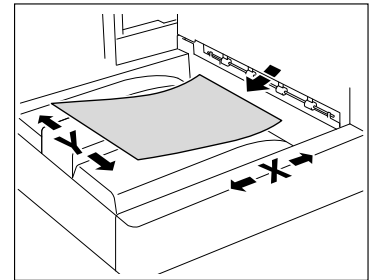

☐ indicates the paper size with the length (X) being shorter than the width (Y).

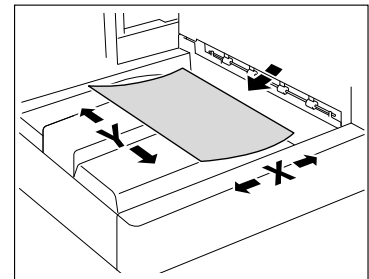

2

Before Using This Machine

2 Before Using This Machine

2.1 Part names and their functions

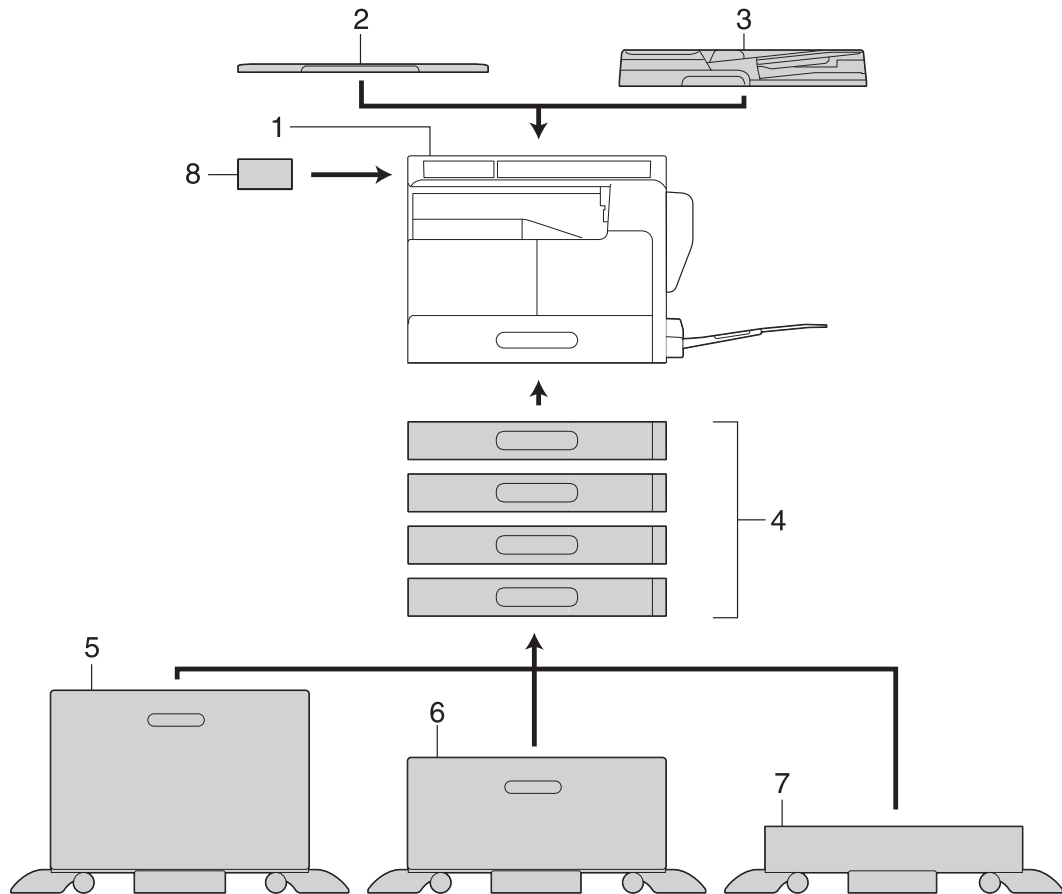

Number	Name	Description
1	Main unit	The original is scanned by the scanner section, and the scanned image is printed by the printer section. The main unit is hereinafter referred to as "this machine", "main unit", or bizhub 306/266 through this manual.
2	Original Cover OC-512	Fixes the loaded originals. This unit is hereinafter referred to as the Original Cover through this manual.
3	Reverse Automatic Document Feeder DF-625	Automatically feeds and scans originals by page. This unit automatically reverses and scans 2-sided originals. This unit is hereinafter referred to as the ADF through this manual.
4	Paper Feeder Unit PF-509	Up to 250 sheets can be loaded onto this paper feeder unit. Up to four trays can be added on this machine. The unit is hereinafter referred to as Tray 2/Tray 3/Tray 4/Tray 5 through this manual.
5	Desk DK-706	This machine can be installed on this desk. By using the desk, you can install this machine on the floor. One tray can be added on this desk. This desk is hereinafter referred to as the Desk through this manual.

Number	Name	Description
6	Desk DK-707	This machine can be installed on this desk. By using the desk, you can install this machine on the floor. Up to two trays can be added on this desk. This desk is hereinafter referred to as the Desk through this manual.
7	Desk DK-708	This machine can be installed on this desk. By using the desk, you can install this machine on the floor. Up to four trays can be added on this desk. This desk is hereinafter referred to as the Desk through this manual.
8	Extended Operation Panel MK-750	An address book registration number and address can be registered or recalled while using fax and scanning functions.

The following options are built into this machine and are not shown in the figure.

Number	Name	Description
9	Upgrade Kit UK-213	Allows this machine to work in the wireless network environment. For details, refer to [User's Guide Network Administrator].
10	FAX Kit FK-510	Allows this machine to function as a fax machine. Alternatively, it allows more telephone lines to be connected.

2.2 Main Body

2.2.1 Exterior of the main unit

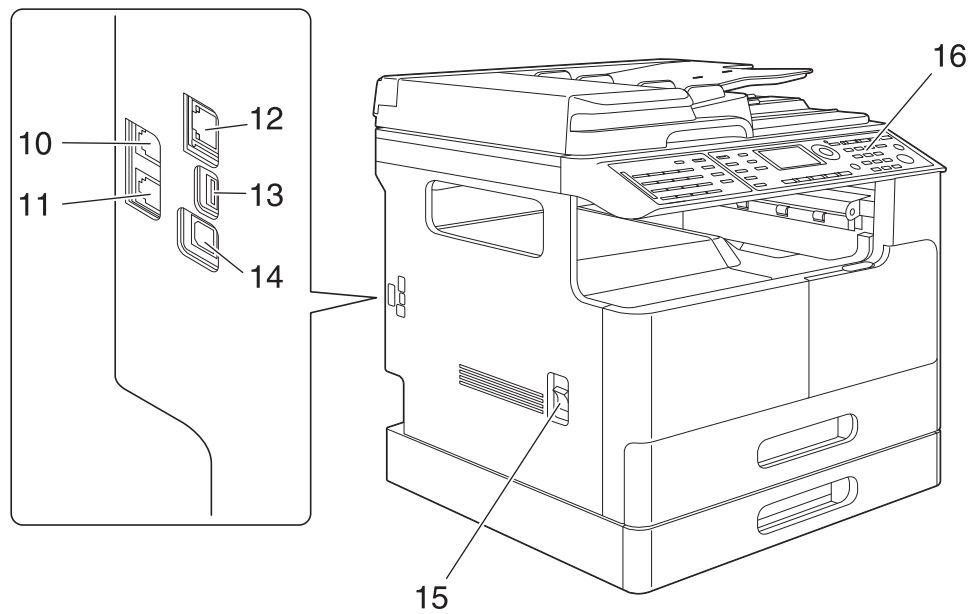
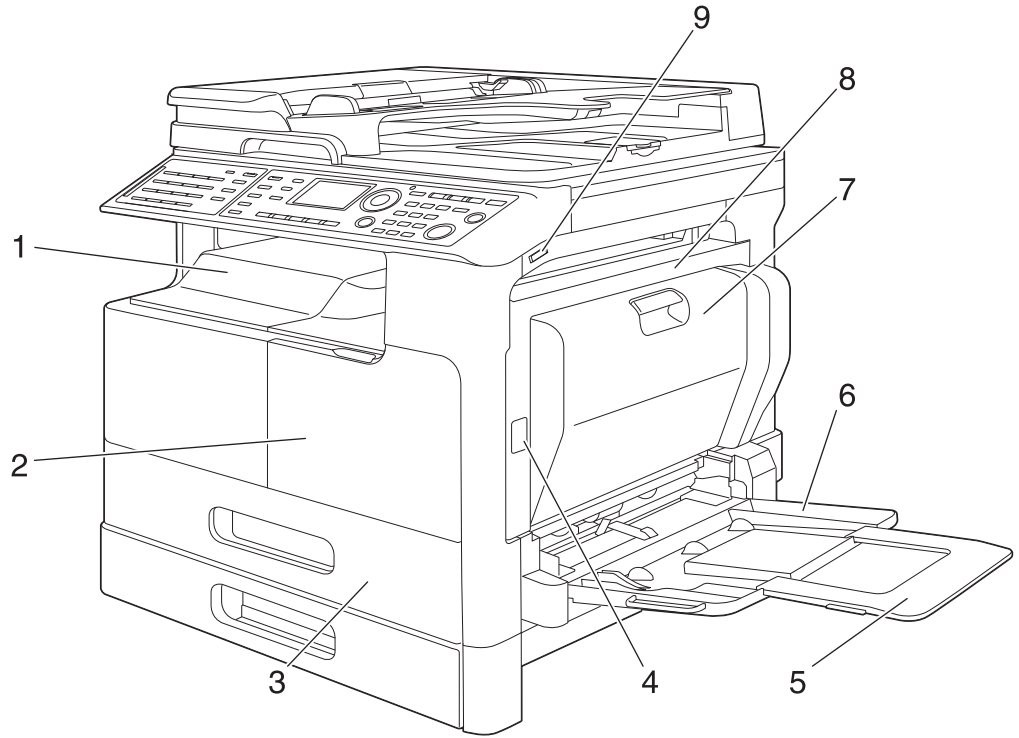

Number	Name
1	Output Tray
2	Front Cover
3	Tray1
4	1st Side Cover Release Button
5	Bypass Tray Extension
6	Bypass Tray
7	Auto Duplex Unit
8	1st Side Cover
9	USB Port (Host: Scan to USB)
10	Jack for connecting a telephone (TEL PORT)
11	Telephone Jack (LINE PORT)
12	Network Connector (10 Base-T/100 Base-TX)
13	USB Port (Type A) USB 2.0/1.1
14	USB Port (Type B) USB 2.0/1.1
15	Power Switch
16	Control Panel

2.2.2 Interior of the main unit

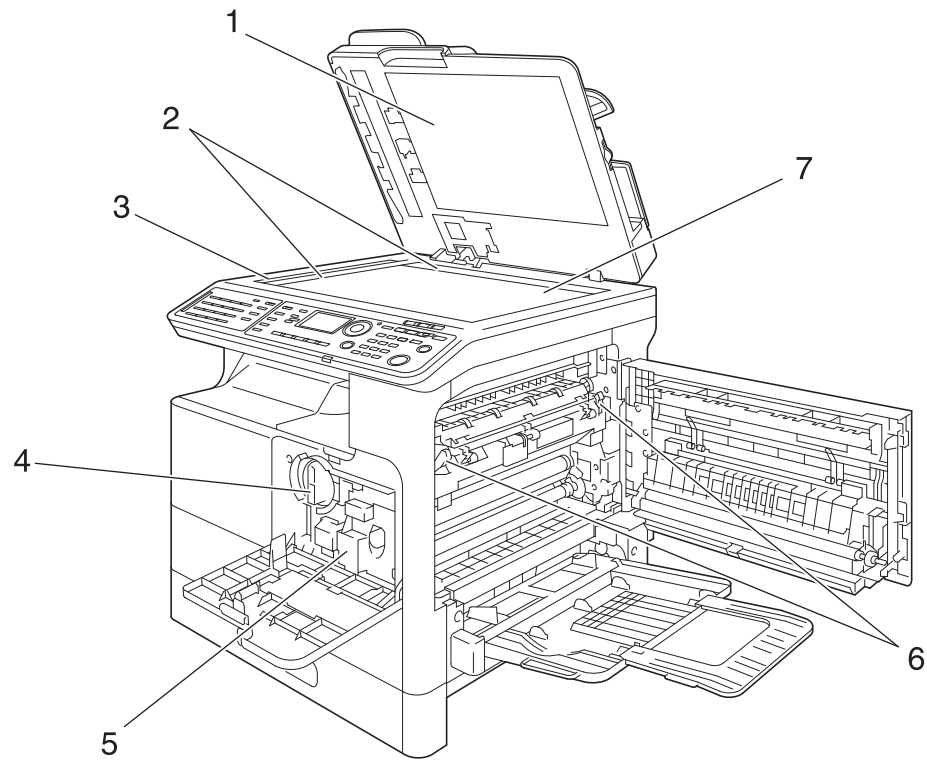

Number	Name
1	Original Pad
2	Original Scale
3	Slit Scan Glass
4	Toner Bottle
5	Drum Unit
6	Fusing Unit Release Lever
7	Original Glass

2.2.3 Reverse Automatic Document Feeder (Option)/Automatic Duplex Unit

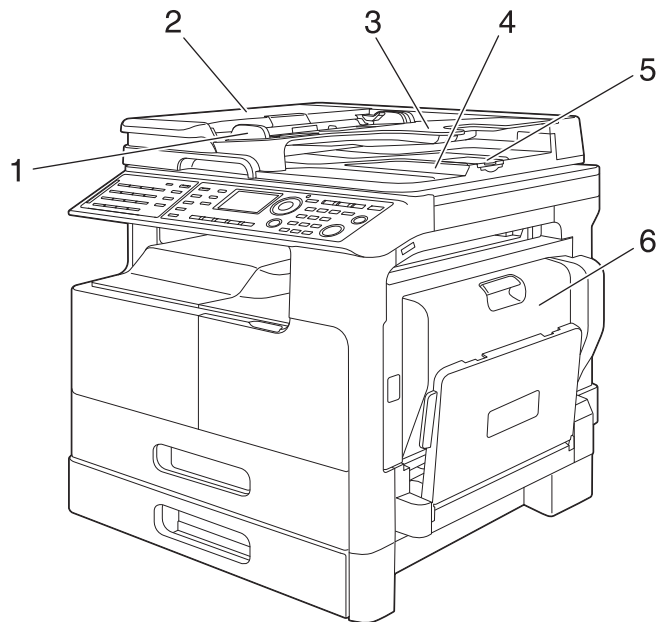

Reverse Automatic Document Feeder

Number	Name
1	Lateral Guide
2	Document Feeder Cover
3	Original Tray
4	Original Output Tray
5	Stopper

Automatic Duplex Unit

Number	Name
6	Duplex Cover

2.2.4 Paper Feeder Unit (Option)

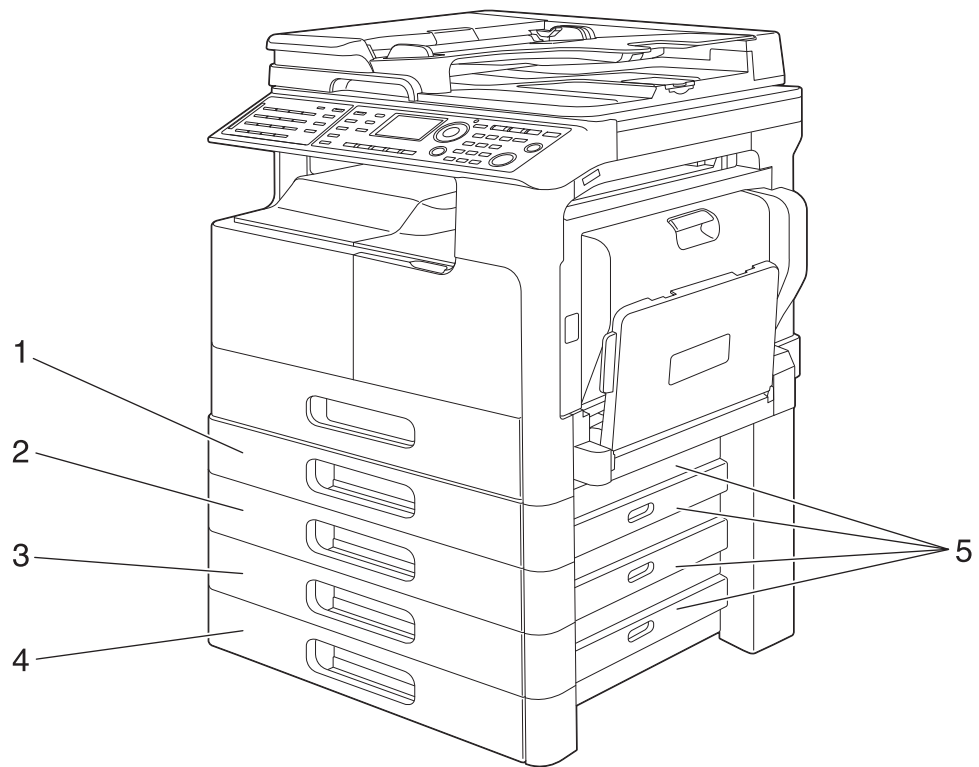

Number	Name
1 to 4	Tray 2/3/4/5
5	2nd/3rd/4th/5th Side Cover

2.3 Control Panel

2.3.1 Name and function of each part on the control panel

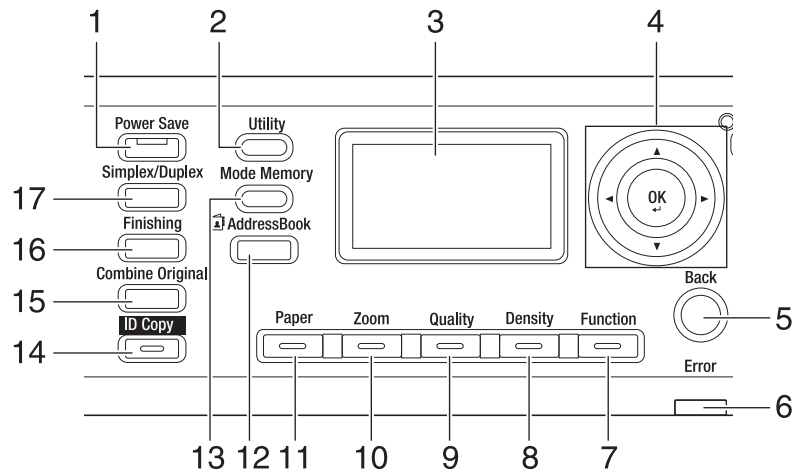

Number	Name	Functions	Reference Page
1	Power Save	Press this key to switch to sleep mode.	p. 2-21
2	Utility	In the Utility screen, you can configure the following settings: Machine setting, paper source setup, custom size memory, drum dehumidify, admin. management, copy setting 1, copy setting 2, confirm mode.	p. 6-3
3	Display	This area displays the number of copies, zoom ratio, Utility screen, icons, and error messages.	-
4	▲, ▼, ◀, ▶ OK	Use the ▲, ▼, ◀, and ▶ key to move an option item on the Display or change settings. Press the OK key to determine settings.	-
5	Back	Press this key to return to the previous page.	-
6	Error	This lamp lights up or flashes when an error occurs.	p. 7-5
7	Function	Press this key to configure the following advanced copy settings in the copy function screen: BOOK SEP., ERASE, OUTER ERASE, NEG. ←→ POS., PAGE MARGIN, STAMP, MIXEDORIGINAL, X/Y ZOOM	p. 5-12
8	Density	Press this key to select the density with which to scan a copy original.	p. 4-22
9	Quality	Press this key to select the image quality of the original from [TEXT], [PHOTO], and [TEXT/PHOTO].	p. 4-4
10	Zoom	Press this key to enlarge or reduce an image in copy mode.	p. 4-19
11	Paper	Press this key to select a paper tray to be used.	p. 4-8
12	AddressBook	Press this key to display the information registered in the one-touch dial, group dial, and speed dial.	-
13	Mode Memory	Press this key to register or recall the configured copy function.	p. 5-20
14	ID Copy	Press this key to copy the contents of the front and back sides of a card-size original such as a driver's license, on one sheet.	p. 5-10
15	Combine Original	Press this key to copy a multi-page original on one sheet.	p. 5-8

Number	Name	Functions	Reference Page
16	Finishing	Press this key to select the copy finishing mode.	p. 5-5
17	Simplex/Duplex	Press this key to use the 1-Sided or 2-Sided printing function.	p. 5-6

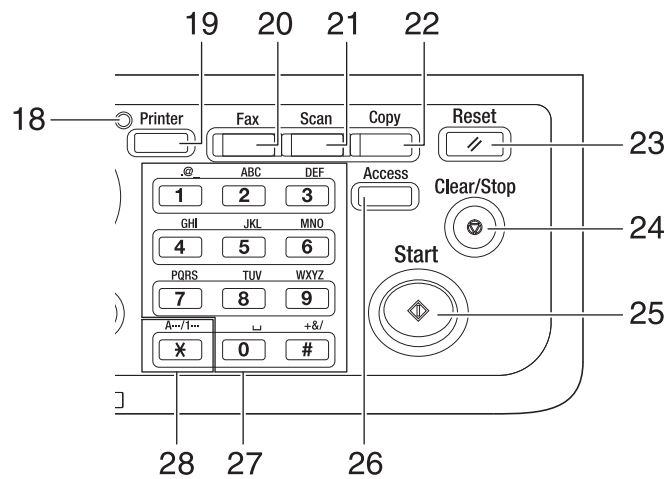

Number	Name	Functions	Reference Page
18	Printer Indicator	Lights up green when the machine is in the printer mode.	-
19	Printer	Press this key to use the printer mode. For details, refer to [User's Guide Print].	-
20	Fax	Press this key to switch to the fax mode. The lamp lights up green when the machine is in the fax mode.	-
21	Scan	Press this key to switch to the scan mode. The lamp lights up green when the machine is in the scan mode.	-
22	Copy	Press this key to switch to copy mode. The lamp lights up green when the machine is in the copy mode.	-
23	Reset	<ul style="list-style-type: none"> Press this key to reset all settings you entered on the Control Panel. (Excluding the registered settings) Erases the jobs you are currently configuring. 	-
24	Clear/Stop	<ul style="list-style-type: none"> Press this key to clear the digit you are currently entering. Stops continuous copy operations. Stops PC printing. 	p. 4-7
25	Start	<ul style="list-style-type: none"> Starts a copy operation. Pressing this key in the warm-up state starts the Next Copy Job function. Lights up blue when the machine is ready to accept a copy job, and lights up orange when the machine is not ready to start a copy operation. 	p. 4-3 p. 2-20
26	Access	Press this key to use account track.	p. 5-11
27	Keypad	<ul style="list-style-type: none"> Specify the number of copies. Enter various settings. 	-
28	A.../1...	Press this key to switch between numerals and letters you enter from the Keypad .	-

2.3.2 Extended Operation Panel MK-750 (Option)

For details on using **Extended Operation Panel MK-750**, refer to [User's Guide Fax] or [User's Guide Scan].

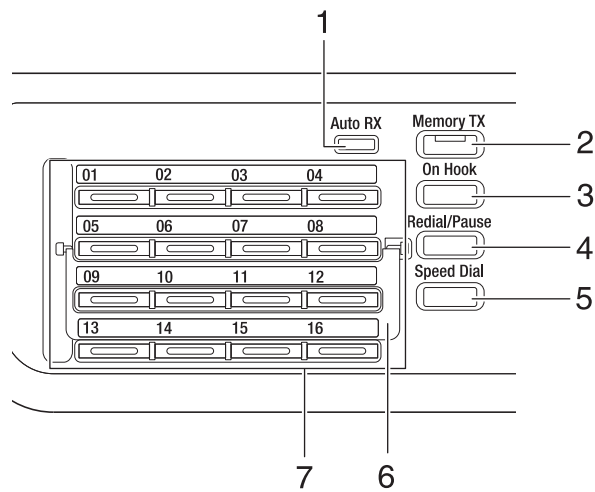

Number	Name	Functions	Reference Page
1	Auto RX Indicator	Lights up green when the machine is set in Auto RX mode.	-
2	Memory TX	Press this key to configure a memory transmission. This lamp lights up green when the Memory TX mode is set to ON.	-
3	On Hook	Press this key to set the machine in the state where the phone is taken off the hook. Repressing this key returns to the state to hang up.	-
4	Redial/Pause	<ul style="list-style-type: none"> Press this key to redial the last recipient you called. This function is available during the wait time to make a call from an extension line to an external line, or to receive information from an information service. 	-
5	Speed Dial	Press this key to dial a fax number that has been pre-registered in the speed dial.	-
6	Switching Plate	Use this plate to switch One-Touch Dial Key numbers. When the Switching Plate is closed downward, one-touch dial keys 01 to 16 are available. When it is opened upward, one-touch dial keys 17 to 32 are available.	-
7	One-Touch Dial Key	<ul style="list-style-type: none"> Press this key to dial a pre-registered destination. Use keys 01 to 32 to configure one-touch dial key and group dial settings. Use keys 29 to 32 to configure program dial settings. 	-

2.3.3 Display message



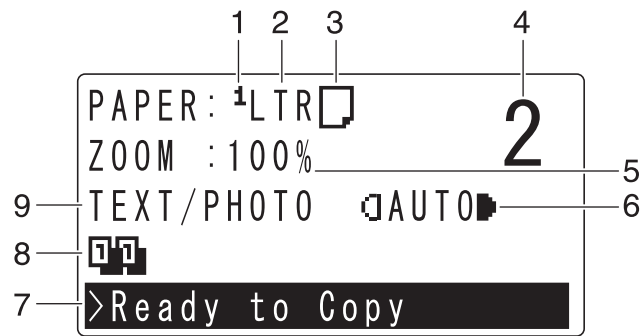



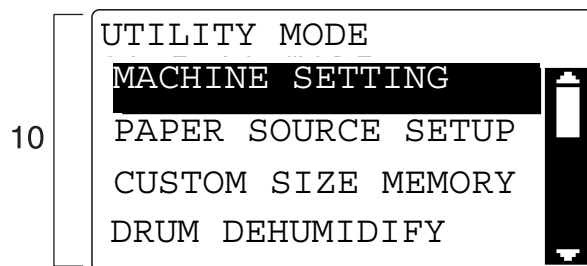









Copy mode screen

























Utility screen



Number	Display message	Description	
1	Paper Tray	Displays the selected paper tray.	
		1	Indicates that Tray1 is selected.
		2	Indicates that Tray2 is selected.
		3	Indicates that Tray3 is selected.
		4	Indicates that Tray4 is selected.
		5	Indicates that Tray5 is selected.
2	Paper size	Indicates that Bypass Tray is selected.	
		[X/Y]	Indicates that custom size paper is set.

Number	Display message	Description
3	Paper type	Displays the selected paper type.
	 	Indicates that Plain Paper is selected.
	 	Indicates that Recycled Paper is selected.
	 	Indicates that Special Paper is selected.
	 	Indicates that Single Side Only is selected.
	 	Indicates that Thick 1 is selected.
	 	Indicates that Thick 2 is selected.
	 	Indicates that Transparency is selected.
	 	Indicates that Envelope is selected.

Number	Display message	Description
	 	Indicates that Duplex 2nd Side and Plain Paper are selected.
	 	Indicates that Duplex 2nd Side and Thick 1 are selected.
	 	Indicates that Duplex 2nd Side and Thick 2 are selected.
	 	Indicates that Duplex 2nd Side and Recycled Paper are selected.
4	Number of Copies	Displays the number of copies. 1 to 999 can be set.
5	Zoom	Displays the specified zoom ratio.
	Auto	Indicates that Auto Zoom is selected. The most appropriate zoom ratio is automatically selected based on the size of the loaded original and the specified paper size.
	100%	Indicates that Full size (100%) is selected. Copies data in the same size as the original.
	[X/Y]	Indicates that X/Y Variable Zoom Ratio is selected. Copies data with different zoom ratios in the vertical and horizontal directions.
6	Copy Density	Displays the copy density setting status you have specified at copy density setting. If [MANUAL] is selected, the density is displayed on a level one to nine on the copy mode screen.
7	Message display	Displays the status of this machine and the status of the PC printing in copy mode.

Number	Display message	Description
8	Icons representing functions	The specified status is displayed with an icon.
		Indicate that 2in1 is selected.
		Indicate that 4in1 is selected.
		Indicates that Book Separation is selected.
		Indicates that Erase is selected.
		Indicates that Group is selected.
		Indicates that Sort is selected.
		Indicates that ID Copy is selected.
		Indicates that Page Margin is selected.
		Indicates that Neg./Pos. Reverse is selected.
		Indicates that Stamp is selected.
	  	Simplex/Duplex is selected.
		Indicates that Mixed Original is selected.
		Indicates that Outer Erase is selected.

Number	Display message	Description
9	Original Type	Displays the image quality setting of the original.
	Text/Photo	Indicates that the Text/Photo Quality is selected. Select this mode to copy printed originals containing both text and images, such as newspapers and magazines. You can select this setting in combination with the Auto Density mode.
	Photo	Indicates that Photo Quality is selected. Select this mode to copy printed originals, such as pamphlets and catalogs. Select this setting to produce better reproductions of halftone original images (photographs, etc.) that cannot be reproduced with Text Quality.
Text	Indicates that Text Quality is selected. Select this mode when copying documents containing only text. The edges of copied text are reproduced with sharpness, providing an image that is easy to read. You can select this setting in combination with the Auto Density mode.	
10	Mode or function	Displays setting menus or options.

2.4 Power

2.4.1 Turning on the power

Tips

- The warm up time is 15 seconds at room temperature of 23°C.
- You can program the next copy job even during warm up. For details, refer to page 2-20.

Press the | side of **Power Switch**.

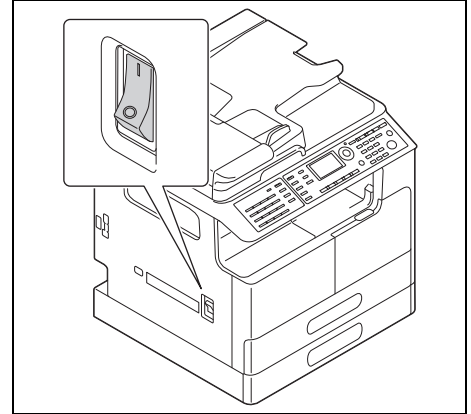

The indicator on **Start** lights up in orange and [PLEASE WAIT!] is displayed on the **Display**.

After that, the indicator on **Start** lights up in blue and [Warming Up] is displayed on the **Display**.

2.4.2 Turning off the power

- 1 Confirm that all jobs have finished.
- 2 Press the ○ side of **Power Switch**.

2.4.3 Initial mode

The setting when this machine is turned on or reset is referred to as "initial mode". The initial mode is used as a basic mode to perform all operations.

Copy mode

- Number of copies: 1
- Copy density: Auto
- Zoom ratio: Full size (100%)
- Paper: Auto Paper
- Finishing: Non-sort



Reference

The initial mode can be changed in the Utility screen. For details, refer to page 6-3.

2.4.4 Auto Panel Reset

This function returns you to the initial mode when the specified time has elapsed after copying is finished or the user paused operations of this machine. (The factory default is [1min].)



Reference

The time period until the auto panel reset function is enabled can be set to 30 seconds or between one and five minutes. The auto panel reset function can be disabled. For details, refer to page 6-5.

2.4.5 Sleep mode

Sleep mode causes this machine to enter power-saving mode instead of turning off the power.

In sleep mode, **Power Save** lights up in green and the **Display** on the **Control Panel** turns off.

Conditions to cause this machine to enter sleep mode

- When **Power Save** is pressed
- When the specified time has elapsed after the user paused operations of this machine (The factory default is [15min])



Tips

If the auto shut time function is enabled even in the sleep mode, the power of this machine turns off.



Reference

The time period until sleep mode is enabled can be set between 1 and 60 minutes. For details, refer to page 6-6.

Further power-saving during the sleep mode becomes possible. For details, refer to page 6-19.

2.4.6 Auto shut time

This function turns off the power to save power when the specified period of time has elapsed after the user stopped using this machine. (The factory default is [180min].)



Reference

The time until the auto shut time function is turned off automatically can be set between 15 and 240 minutes. For details, refer to page 6-6.

2.4.7 Next Copy Job

This function reserves the next copy job by loading the original when [Warming Up] is displayed on the **Display** and the **Start** key is pressed.

When Warming Up disappears, scanning of the loaded original starts to perform copy operation.

2.5 Saving electricity

When you want to save electricity for power saving, it will be convenient to use sleep mode.

This section describes how to automatically switch to sleep mode.

2.5.1 Setting sleep mode

- 1 Press the **Utility** key.
The Utility screen appears.
- 2 Use the **▲/▼** key to select [MACHINE SETTING], then press the **OK** key.
The machine setting screen appears.
- 3 Use the **▲/▼** key to select [SLEEP MODE], then press the **OK** key.
- 4 Enter time until the function is enabled using the **Keypad**, then press the **OK** key.

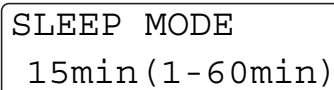

SLEEP MODE
15min (1-60min)

Tips

- Timer setting can be configured between one and 60 minutes.
- To correct the value, press the **Clear/Stop** key.

2.5.2 Specifying the auto shut time

Tips

To specify the auto shut time, the display auto shut setting must be enabled in Administrator Settings. For details, refer to page 6-6 and page 6-19.

- 1** Press the **Utility** key.
The Utility screen appears.
- 2** Use the **▲/▼** key to select [MACHINE SETTING], then press the **OK** key.
The machine setting screen appears.
- 3** Use the **▲/▼** key to select [AUTO SHUT TIME], then press the **OK** key.
- 4** Use the **▲/▼** key to select [ON], then enter the time required to enable the function using the **Keypad**.

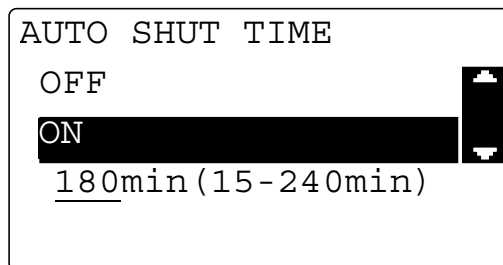

If the auto shut time is already specified, the currently specified time is displayed.

- 5** Press the **OK** key.

Tips

- The timer can be specified to be between 15 and 240 minutes.
- To correct the numeric value, press the **Clear/Stop** key.

A large, bold, black number '3' is centered within a gray square. The square is positioned to the left of the text 'Before Making Copies'.

Before Making Copies

3 Before Making Copies

3.1 Paper

3.1.1 Confirm the Available Paper Types

Paper type	Paper weight	Paper capacity
Plain paper	17 lb to 23-15/16 lb (64 to 90 g/m ²)	Bypass Tray: 100 sheets Tray 1: 250 sheets Tray 2: 250 sheets Tray 3: 250 sheets Tray 4: 250 sheets Tray 5: 250 sheets
Thick 1	24-3/16 lb to 31-15/16 lb (91 to 120 g/m ²)	Bypass Tray: 20 sheets Tray 1: 20 sheets
Thick 2	32-3/16 lb to 41-3/4 lb (121 to 157 g/m ²)	Bypass Tray: 20 sheets Tray 1: 20 sheets
Recycled paper	17 lb to 23-15/16 lb (64 to 90 g/m ²)	Bypass Tray: 100 sheets Tray 1: 250 sheets Tray 2: 250 sheets Tray 3: 250 sheets Tray 4: 250 sheets Tray 5: 250 sheets
Transparency	-	Bypass Tray: 10 sheets Tray 1: 10 sheets
Envelope	-	Bypass Tray: 10 sheets Tray 1: 10 sheets



Tips

Tray2/Tray3/Tray4/Tray5 are optional.

3.1.2 Confirm the Available Paper Sizes

Paper feed port	Allowable sizes
Bypass Tray	11 × 17□ to 5-1/2 × 8-1/2□/□, A3□ to B6□, A6□, 8 × 13□ ^{*1} Width: 3-9/16 to 11-11/16 inches (90 mm to 297 mm) Length: 5-1/2 to 17 inches (140 mm to 432 mm) ^{*1} Foolscape is provided with the following six types of paper sizes: 8-1/2 × 13-1/2, 220 mm × 330 mm, 8-1/2 × 13, 8-1/4 × 13, 8-1/8 × 13-1/4, and 8 × 13. Any one of these sizes is selectable. For details, contact your service representative.
Tray1	11 × 17□ to 5-1/2 × 8-1/2□/□, A3□ to B6□, A6□, 8 × 13□ ^{*1} , 16K□/□, 8K□ Width: 3-9/16 to 11-11/16 inches (90 mm to 297 mm) Length: 5-1/2 to 17 inches (140 mm to 432 mm) ^{*1} Foolscape is provided with the following six types of paper sizes: 8-1/2 × 13-1/2, 220 mm × 330 mm, 8-1/2 × 13, 8-1/4 × 13, 8-1/8 × 13-1/4, and 8 × 13. Any one of these sizes is selectable. For details, contact your service representative.
Tray2	11 × 17□ to 8-1/2 × 11□/□, A3□ to B5□ Width: 7-3/16 to 11-11/16 inches (182 mm to 297 mm) Length: 7-3/16 to 17 inches (182 mm to 432 mm)
Tray3	11 × 17□ to 8-1/2 × 11□/□, A3□ to B5□ Width: 7-3/16 to 11-11/16 inches (182 mm to 297 mm) Length: 7-3/16 to 17 inches (182 mm to 432 mm)
Tray4	11 × 17□ to 8-1/2 × 11□/□, A3□ to B5□ Width: 7-3/16 to 11-11/16 inches (182 mm to 297 mm) Length: 7-3/16 to 17 inches (182 mm to 432 mm)
Tray5	11 × 17□ to 8-1/2 × 11□/□, A3□ to B5□ Width: 7-3/16 to 11-11/16 inches (182 mm to 297 mm) Length: 7-3/16 to 17 inches (182 mm to 432 mm)



Tips

Tray2/Tray3/Tray4/Tray5 are optional.

3.1.3 Precautions for using paper

Do not use the following types of paper. Not observing these precautions may lead to reduced print quality, a paper jam or a damage to the machine.

- OHP transparencies that have already been fed through the machine (even if they are still blank)
- Paper that has been printed on with a heat-transfer printer or an inkjet printer
- Folded, curled, wrinkled, or torn paper
- Paper that has been left unwrapped for a long period of time
- Damp paper, perforated paper, or paper with punched holes
- Extremely smooth or extremely rough paper, or paper with an uneven surface
- Treated paper such as carbon-backed paper, thermal paper, pressure-sensitive paper, or iron-on transfer paper
- Paper that has been decorated with foil or embossing
- Paper of a non-standard shape (paper that is not rectangular)
- Paper that is bound with glue, staples or paper clips
- Paper with labels attached
- Paper with ribbons, hooks, buttons, etc., attached

3.2 Image copy/printing area

Note that images within the following areas cannot be copied or printed.

- Top edge: 3/16 inches (4 mm) (at full size)
- Bottom edge: 3/16 inches (4 mm) (at full size)
- Right edge: 3/16 inches (4 mm) (at full size)
- Left edge: 3/16 inches (4 mm) (at full size)



Reference

If documents are printed from the computer, refer to [User's Guide Print].

3.3 Storing paper

Handle paper by following the precautions below.

- Do not store paper in the locations subject to direct sunlight and near open flames, and the humid and dusty locations.
- Once paper is taken out of a packet, put it in a plastic bag and be sure to store it in a cool and dark location.
- Do not place paper within reach of infants or children.

3.4 Loading paper

This section describes how to load paper into each paper tray.

For the types of paper to be used, refer to page 8-3.

3.4.1 Loading paper into Tray1

- 1 Pull out **Tray1**.

NOTICE

Be careful not to touch the surface of the paper take-up roller with your hand.

- 2 Press down the lifter plate until it "clicks" into position.

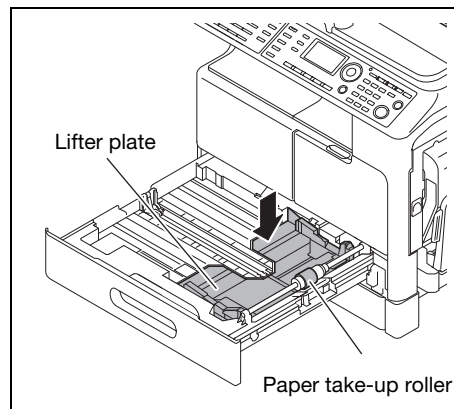

- 3 Slide the lateral guide to fit to the groove according to the paper size.

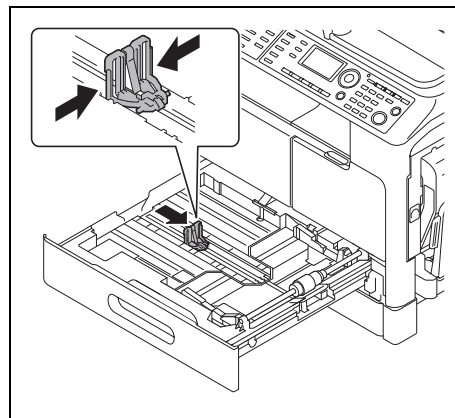

- 4 Load paper.
→ Be sure to load the paper below the tab, so that the stack height does not exceed the ▼ mark.

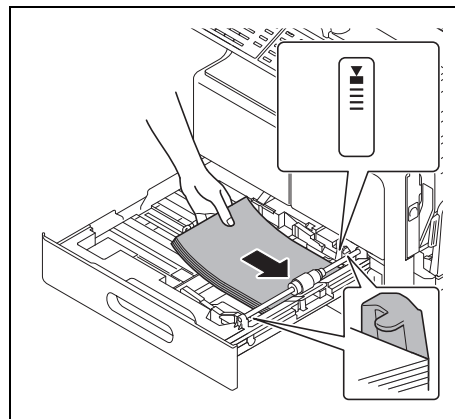

- 5 Adjust the lateral guide to the size of the paper.
→ Push the lateral guide firmly up against the edges of the paper.

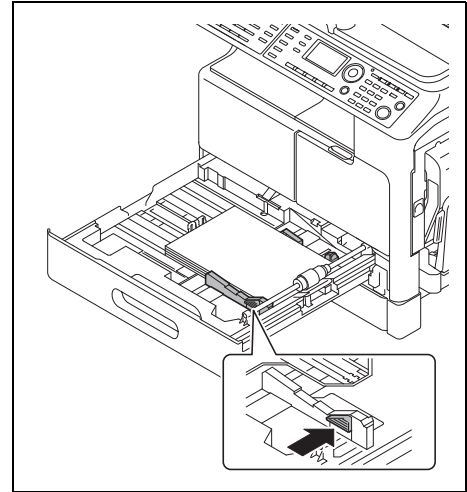

- 6 Reset the tray.

3.4.2 Loading paper to Tray2/Tray3/Tray4/Tray5

- 1 Pull out the tray.
- 2 Press down the lifter plate until it "clicks" into position.

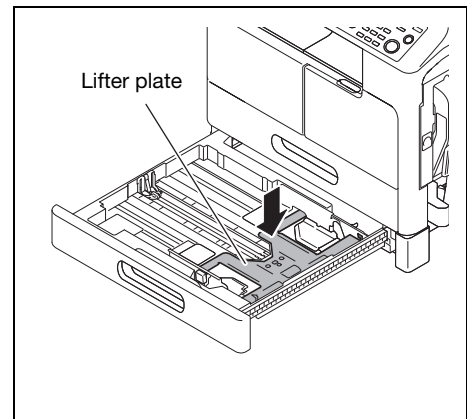

- 3 Slide the lateral guide to fit to the groove according to the paper size.

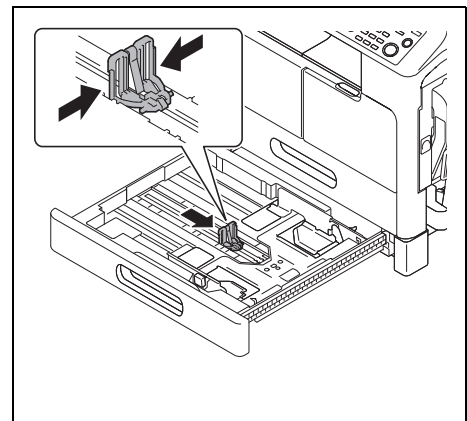

4 Load paper.

- Be sure to load the paper below the tab, so that the stack height does not exceed the ▼ mark.

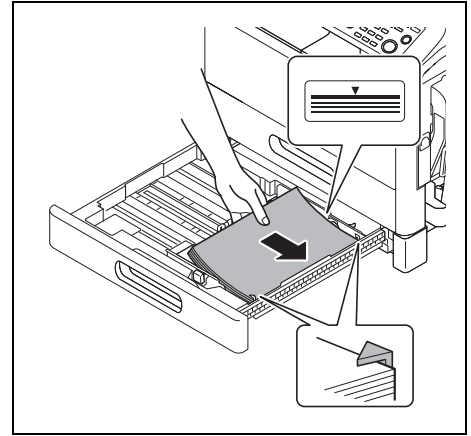
**5** Adjust the lateral guide to the size of the paper.

- Push the lateral guide firmly up against the edges of the paper.

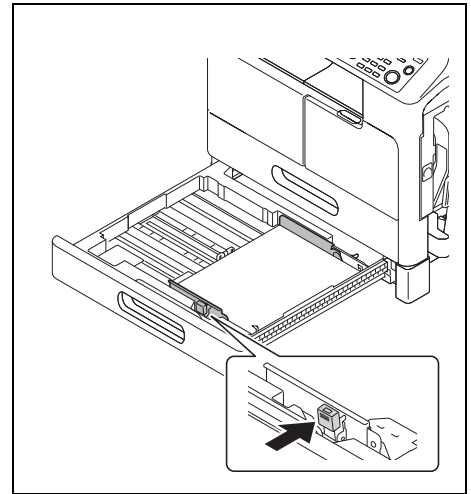
**6** Reset the tray.

3.5 Original

3.5.1 Using ADF

The **ADF** is a device that scans multiple original pages while feeding out them one by one, and automatically outputs scanned pages. To benefit from the more efficient functions of this machine, use the appropriate original.

Using an inappropriate original will likely cause jamming and/or spoiling of the original or machine failure.

3.5.2 Original type

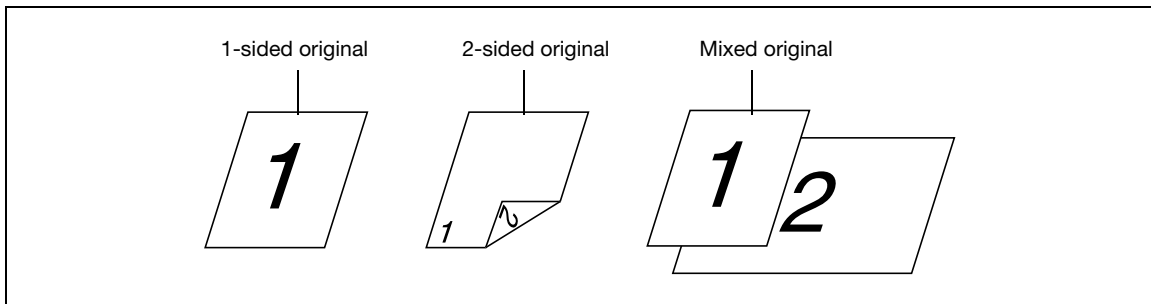

Original loading method	Original type	Original Size
When using the ADF :	1-sided original (9-5/16 lb to 34-1/16 lb (35 g/m ² to 128 g/m ²)) 2-sided original (13-5/16 lb to 34-1/16 lb (50 g/m ² to 128 g/m ²)) Mixed original (13-5/16 lb to 34-1/16 lb (50 g/m ² to 128 g/m ²))	11 × 17□ to 5-1/2 × 8-1/2□/□ (A3□ to A5□/□) Original width: 3-9/16 inches to 11-11/16 inches (90 mm to 297 mm) Original length: 8-1/2 inches to 17 inches (215.9 mm to 431.8 mm) In the mixed original mode, the following combinations are available. 11 × 17□ (A3□) and 8-1/2 × 11□ (A4□) 8-1/2 × 11□ (A4□) and 5-1/2 × 8-1/2□ (A5□) 8-1/2 × 14□ (B4□) and 5-1/2 × 8-1/2□ (B5□)
When using the Original Glass :	Highly translucent or transparent original, book original, three-dimensional objects Max. weight: 4-7/16 lb (2 kg)	11 × 17□ to 5-1/2 × 8-1/2□/□ (A3□ to A5□/□) Original width: Max. 11-11/16 inches (297 mm) Original length: Max. 17 inches (431.8 mm)

3.5.3 Precautions on originals

The following types of originals should not be loaded into the ADF. If loaded, paper may be jammed or the original may be damaged.

- Wrinkled, folded, curled, or torn originals
- Highly translucent or transparent originals, such as OHP transparencies or diazo photosensitive paper
- Coated originals such as carbon-backed paper
- Original of which the basic weight is less than 35 g/m² or greater than 128 g/m².
- Originals that are bound, for example, with staples or paper clips
- Originals that are bound in a book or booklet form
- Originals with pages bound together with glue
- Originals with pages that have had cutouts removed or are cutouts
- Label sheets
- Offset printing masters
- Originals with binder holes
- Originals that have just been printed with this machine
- Photographic paper
- Glossy original such as gloss-coated paper



Tips

When you set the original of custom size on the **Original Glass**, you cannot use the Auto Paper and Auto Zoom functions. If you set the original of custom size, press the **Paper** key to select paper used for copying or press the **Zoom** key to select the zoom ratio. For details, refer to page 4-19.

3.6 Loading the original

The original loading methods are classified into two types: loading the original into the **ADF** and setting the original on the **Original Glass**. Load the original using the method appropriate for the type of original being used.

3.6.1 Loading the original into the ADF

- 1 Open **Lateral Guide**.

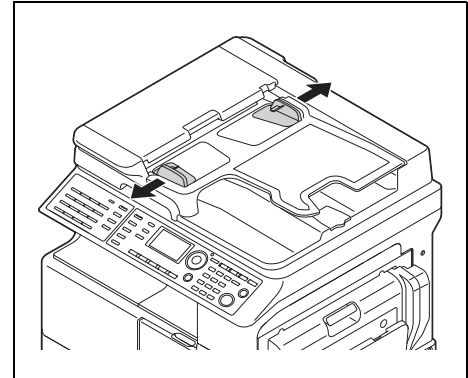

- 2 Load the original with the side you want to copy facing up.

→ Do not load more than 70 sheets into the ADF at a time, and do not load the sheets up to the point where the top of the stack is higher than the ▼ mark. Doing so will likely cause jamming or spoiling of the original, or machine failure.

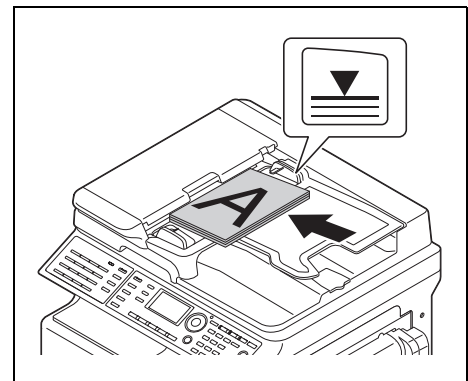

- 3 Adjust the **Lateral Guide** to the original size.

→ If the original is not loaded correctly, it may not be fed in straight.

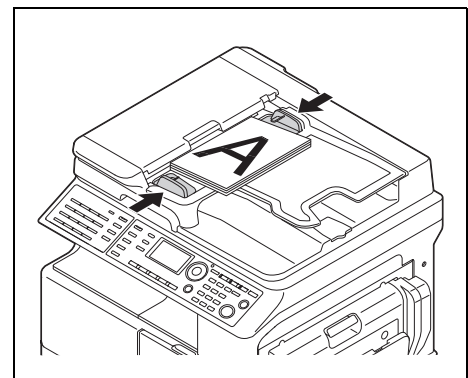

Tips

If you load the original with two sides into the **ADF**, the front and back side of the original are inversely scanned automatically. For details on how to copy a 2-sided original, refer to page 5-6.

3.6.2 Setting the original on the Original Glass

When loading plain paper or paper that is not appropriate for the **ADF**, follow the below procedure.

- 1 Open the **ADF**.
- 2 Set the original with the side you want to copy facing down.

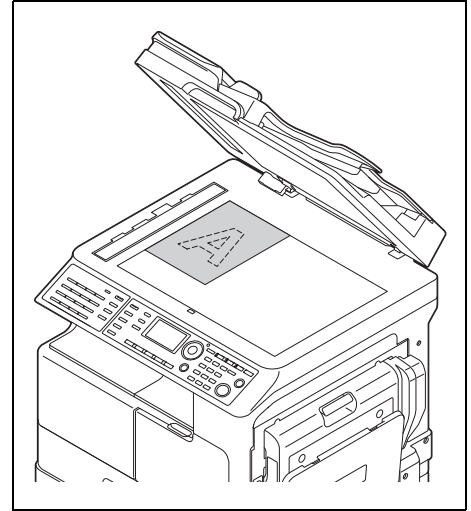

- Set the original along the **Original Scale** on the left and at the top of the **Original Glass**.

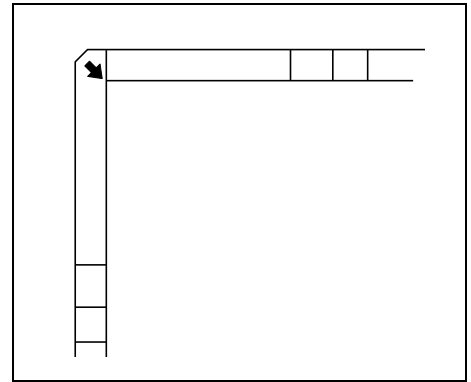

- 3 Gently close the **ADF**.

Tips

- You can copy the 2-sided original by setting it on the **Original Glass**. For details on how to copy a 2-sided original, refer to page 5-6.
- When you use Outer Erase function, do not close the **ADF**. Place the original anywhere on the **Original Glass**. The area surrounding the original text will be excluded from the copy. For details, refer to page 5-15.

3.6.3 Loading the highly translucent or transparent original

When you set the highly translucent or transparent original, such as OHP transparencies, tracing paper, and diazo photosensitive paper, follow the below procedure.

- 1 Open the **ADF**.
- 2 Set the original with the side you want to copy facing down.
→ Set the original along the **Original Scale** on the left and at the top of the **Original Glass**.
- 3 Place a blank sheet of paper that is the same size as the original over the original.

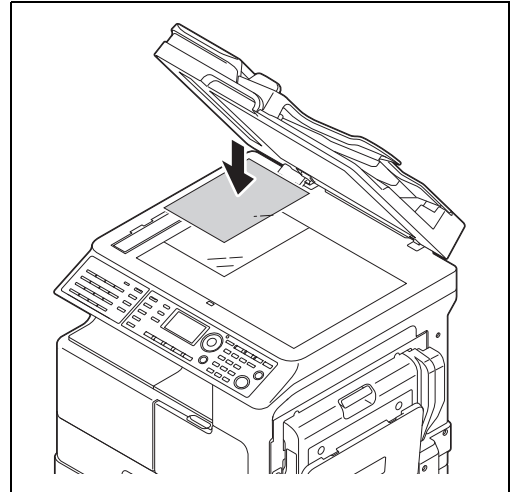

- 4 Gently close the **ADF**.

3.6.4 Setting the book original

When setting the bound two-page spread original, follow the below procedure.

For details on the book separation copy, refer to page 5-12.

NOTICE

*Do not place an original weighing more than 4-7/16 lb (2 kg) on the **Original Glass**. Furthermore, do not exert strong pressure to press down on a book or any other form of original that has to be spread out on the original glass. Otherwise, the machine may be damaged or a failure may occur.*

1 Open the **ADF**.

2 Set the book original onto the **Original Glass**.

→ For the original spread over two facing pages, align it with the  mark on the back-left corner of the **Original Scale**.

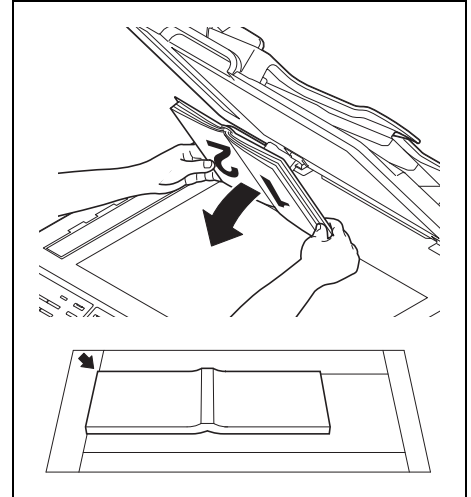

→ For book separation copy, place the top part (upper part) of the original at the back side, and align the center of the book original with  mark of the **Original Scale** at the back.

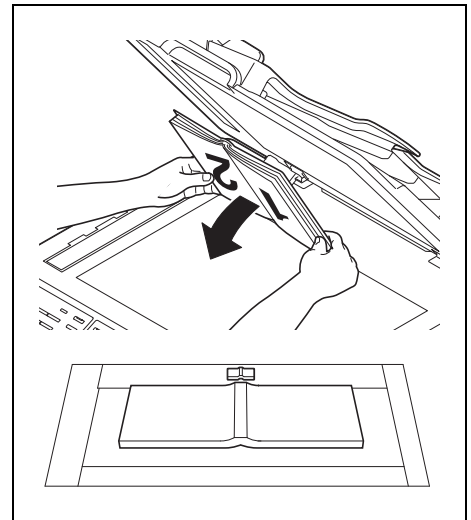

3 Gently close the **ADF**.

3.6.5 Setting originals of different sizes (Mixed Original)

Mixed Original is a function to set originals of different sizes into the **ADF** and make copies at a time.

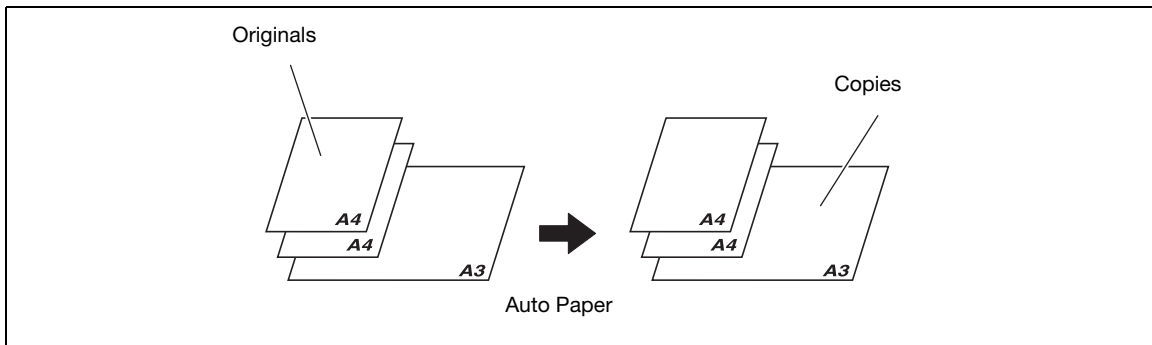

Tips

The Mixed Original function is only available for originals of the same width. The following shows combinations of originals.

- 11 × 17 (A3) and 8-1/2 × 11 (A4)
- 8-1/2 × 11 (A4) and 5-1/2 × 8-1/2 (A5)
- 8-1/2 × 14 (B4) and 5-1/2 × 8-1/2 (B5)

1 Open **Lateral Guide**.

2 Load the original with the side you want to copy facing up.

- Do not load more than 70 sheets into the ADF at a time, and do not load the sheets up to the point where the top of the stack is higher than the ▼ mark. Doing so will likely cause jamming or spoiling of the original, or machine failure.

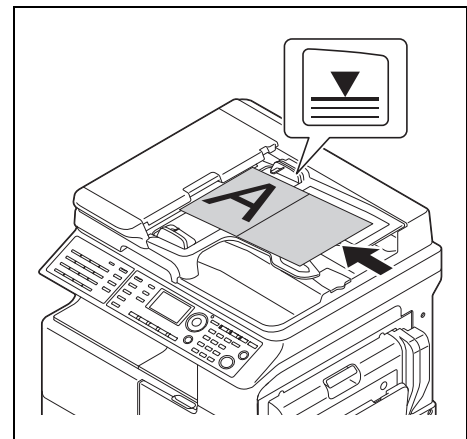

3 Adjust the **Lateral Guide** to the original size.

- If the original is not loaded correctly, it may not be fed in straight.

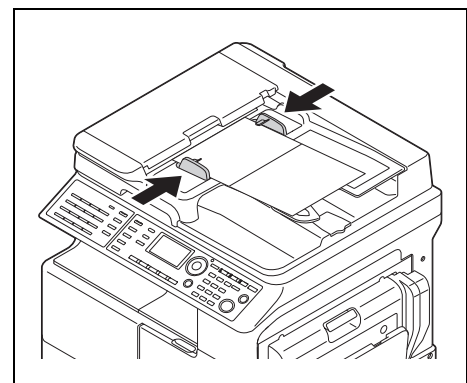

4 Press the **Function** key.

5 Use the ▲/▼ key to select [MIXEDORIGINAL], then press the **OK** key.

- 6 Use the ▲/▼ key to select [ON], then press the **OK** key.

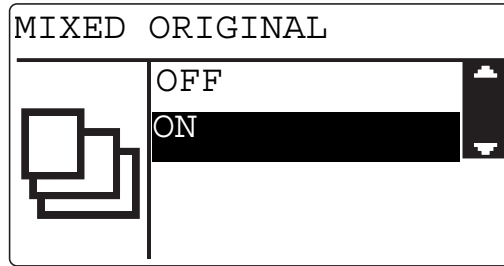

- 7 Press the **Back** key to return to the basic screen.

 is displayed in the basic screen.

- 8 Press the **Paper** key.

- 9 Use the ▲/▼ key to select [AUTO], then press the **OK** key.

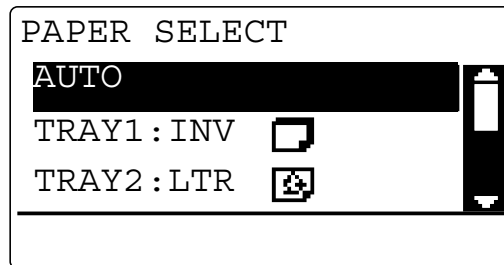

The screen returns to the basic screen.

→ Confirm that [AUTO] appears in the first line of the **Display** of this machine.

- 10 Press the **Start** key.

Tips

The mixed original setting, the auto zoom setting, 1side → 2side copy setting, the book separation copy setting, ID copy setting, 2 in 1/4 in 1 copy setting cannot be set at the same time.

4

Making Copies

4 Making Copies

4.1 Copy

This section describes basic procedures for loading and copying an original.

4.1.1 Basic copying method

- 1 Load the original.
 - For details on how to load the original, refer to page 3-12.

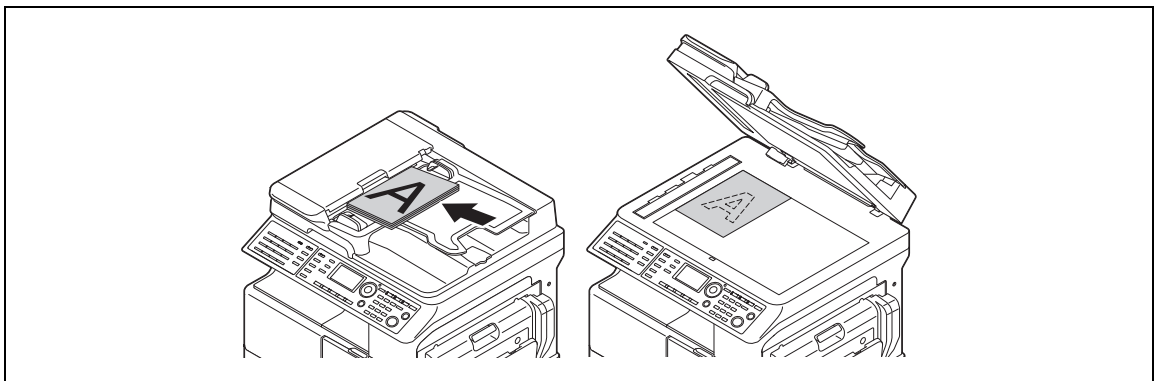

- 2 Configure required settings on the **Control Panel**.
 - For details on the basic functions, refer to page 4-3.
 - For details on the Application, refer to page 5-3.
- 3 Set the number of copies on the **Keypad**,
 - Set the number of copies in the range from 1 to 999.
 - Press the **Clear/Stop** key to clear the number of copies you have set.
- 4 Press the **Start** key.

Copying begins.

 - To stop the copy operation being performed, press the **Clear/Stop** key.
 - For details on stopping copying, refer to page 4-7.

4.1.2 Reducing or enlarging a standard size original to a different standard size

As an example, this section describes procedures for making copies by enlarging a LTR size original to fit 11× 17 size paper.

- 1 Load the original.
→ For details on how to load the original, refer to page 3-12.
- 2 Press the **Zoom** key.
- 3 Use the ▲/▼ key to select [FIXED], then press the **OK** key.
- 4 Use the ▲/▼ key to select [129% LTR → 11 × 17], then press the **OK** key.
The screen returns to the basic screen.

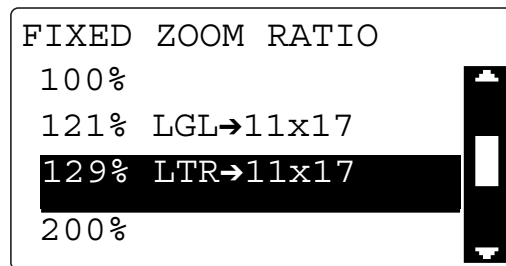

- 5 Confirm the size of paper for copying.
→ If [AUTO] appears, confirm that sheets of 11 × 17 size are loaded in the tray.
→ If [AUTO] does not appear, press the **Paper** key to select the tray in which sheets of 11 × 17 size are loaded.
→ For details on how to select the tray, refer to page 4-8.
- 6 Configure other desired settings.
→ For details on the basic functions, refer to page 4-3.
→ For details on the Application, refer to page 5-3.
- 7 Press the **Start** key.

4.1.3 Specifying the image quality to fit the original

If you specify [TEXT/PHOTO], [TEXT], or [PHOTO] to fit the original to be copied, you can copy the original with clarity.

- 1 Load the original.
→ For details on how to load the original, refer to page 3-12.
- 2 Press the **Quality** key.
- 3 Use the ▲/▼ key to select [TEXT/PHOTO], [TEXT], or [PHOTO], then press the **OK** key.
The screen returns to the basic screen.
- 4 Configure other desired settings.
→ For details on the basic functions, refer to page 4-3.
→ For details on the Application, refer to page 5-3.
- 5 Press the **Start** key.

4.1.4 Specifying the density

- 1 Load the original.
 - For details on how to load the original, refer to page 3-12.
- 2 Press the **Density** key.
- 3 Use the ▲/▼ key to select [AUTO] or [MANUAL].
 - If you select [AUTO], press the **OK** key.
 - If you select [MANUAL], use the ◀/▶ key to select a density from nine levels, then press the **OK** key.

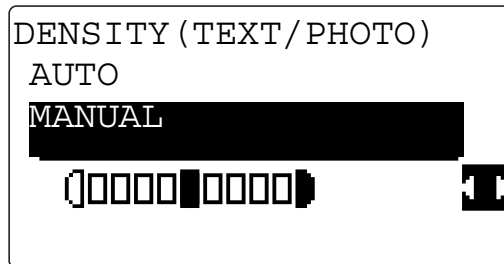

The screen returns to the basic screen.

- 4 Configure other desired settings
 - For details on the basic functions, refer to page 4-3.
 - For details on the Application, refer to page 5-3.
- 5 Press the **Start** key.

Tips

You cannot specify the automatic density control and the [PHOTO] image quality setting at the same time.

4.1.5 Setting the original direction

Set the orientation of the original loaded into the **ADF** or placed on the **Original Glass**. Otherwise, part of the images on the original may not be printed.

- 1 Load the original.
→ For details on how to load the original, refer to page 3-12.
- 2 Press the **Simplex/Duplex** key.
A screen for specifying the 2-sided copy appears.
- 3 Use the ▲/▼ key to select [ORIG. DIRECT].
- 4 Press the ► key. The screen for specifying the original direction is displayed.
- 5 Use the ▲/▼ key to select [TOP], [LEFT], [RIGHT], or [BOTTOM], then press the **OK** key.

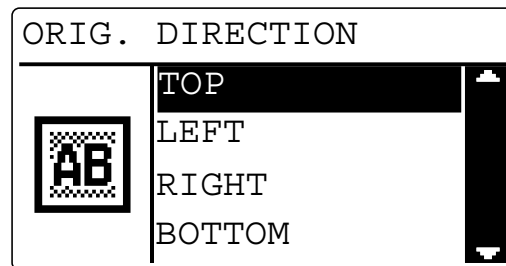

The screen returns to the basic screen.

- 6 Configure other desired settings.
→ For details on the basic functions, refer to page 4-3.
→ For details on the Application, refer to page 5-3.
- 7 Use the **Keypad** to specify the number of copies, then press the **Start** key.

4.2 Stopping, restarting, or erasing the copy job

To interrupt the copy operation being performed, follow the below procedure.

- 1 Configure the copy settings and press the **Start** key.
Copying begins.
- 2 Press the **Clear/Stop** key when copying operations were being carried out.
The [Please wait] message appears and the job stops.
 - To restart the stopped job, select [NO], then press the **OK** key.
 - To erase the stopped job, select [YES], then press the **OK** key.

4.3 Selecting the tray

- 1 Load the original.
→ For details on how to load the original, refer to page 3-12.
- 2 Select the **Paper** key.
- 3 Use the ▲/▼ key to select [AUTO] or one of the trays, then press the **OK** key.
The screen returns to the basic screen.

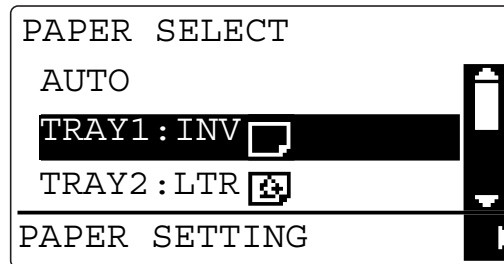

- By selecting [TRAY1] and pressing the ► key, you can specify the size, unit, and type of paper.
- By selecting one of the trays from [TRAY2] to [TRAY5] and pressing the ► key, you can specify the unit of the paper size and paper type.

- 4 Configure other desired settings.
→ For details on the basic functions, refer to page 4-3.
→ For details on the Application, refer to page 5-3.
- 5 Press the **Start** key.

Tips

- If [NO SUITABLE PAPER] appears on the **Display** after you select [AUTO] and press the **Start** key, appropriate paper is not loaded in the tray. Load paper of the appropriate size or select one of the trays, then press the **Start** key again.
- The auto paper setting can't be set at the same time with any of the auto zoom setting, manual zoom setting, book separation copy setting, ID copy setting, erase setting (CENTER, CENTER + FRAME), and outer erase setting.

4.3.1 Auto tray change function

If the currently selected tray has run out of paper during copying or printing, this function automatically switches to another tray to continue copying or printing.

The auto tray change function operates when a tray other than the currently selected tray meets the following conditions.

- When paper of the same size as that of the paper in the currently selected tray is loaded
- When paper of the same type as that of the paper in the currently selected tray is loaded
- When paper is loaded in the same orientation as that of the paper in the currently selected tray
- The type of paper loaded in each tray is [PLAIN], [RECYCLE], or [1-SIDE]
- By using the **Bypass Tray** and **Tray2/Tray3/Tray4/Tray5**, you can continuously copy or print a large number of documents. To continuously copy or print a large number of documents, set the same conditions above for all trays and load paper into them.
- If all trays have run out of paper, replenish paper according to the on-screen instructions. Even if you load paper to a tray other than the tray displayed on the screen, copy or print operations may not restart.

4.3.2 Tray selection order by tray change function

When the auto tray change function operates, the trays are selected in the following priority sequence.

- **Tray1 - Tray2 - Tray3 - Tray4 - Tray5 - Bypass Tray**



Tips

- If **Tray1** or the **Bypass Tray** is set to Special Paper (Transparency), the auto tray change function does not apply to the tray. For details on how to set special paper, refer to page 4-13 or page 6-12.
- When a priority tray is set in the Utility menu, that tray is given priority. For details on the setting procedure, refer to page 6-24.

4.4 Manually making copies

When making copies on paper of a size not loaded in the tray or making copies on special paper such as OHP transparencies, envelopes, and thick paper, use the **Bypass Tray**.

4.4.1 Paper type and number of sheets of paper available for the Bypass Tray

Type:

Paper Type		Number of sheets
Plain paper, recycled paper (thick paper: 17 lb to 23-15/16 lb (64 g/m ² to 90 g/m ²))		100
Special paper	Thick paper 1 (Thick paper: 24-3/16 lb to 31-15/16 lb (91 g/m ² to 120 g/m ²))	20 or less
	Thick paper 2 (Thick paper: 32-3/16 lb to 41-3/4 lb (121 g/m ² to 157 g/m ²))	20 or less
OHP transparency		10 or less
Envelope		10 or less

Size:

- Width: 3-9/16 inches to 11-11/16 inches (90 mm to 297 mm)
- Length: 5-1/2 inches to 17 inches (140 mm to 432 mm)

4.4.2 Adjusting the Bypass Tray

To load large-sized paper, pull out the **Bypass Tray Extension**.

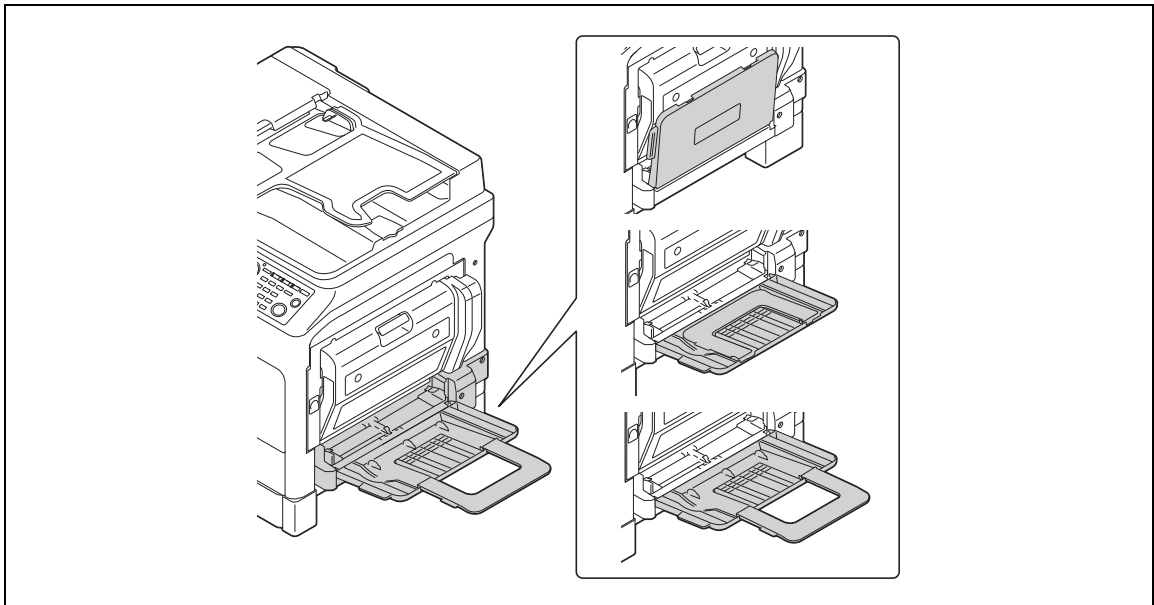

4.4.3 Loading plain paper into the Bypass Tray

Up to 100 sheets of plain paper can be loaded into the **Bypass Tray**.

Tips

If you load paper other than plain paper, you need to specify the paper type on the **Control Panel**.

NOTICE

Load the paper so that the side to be copied is facing down.

Be sure to uncurl the paper before loading it.

- 1 With the print side facing down, load paper into the **Bypass Tray**.
 - Do not load the sheets up to the point where the top of the stack is higher than the ▲ mark.

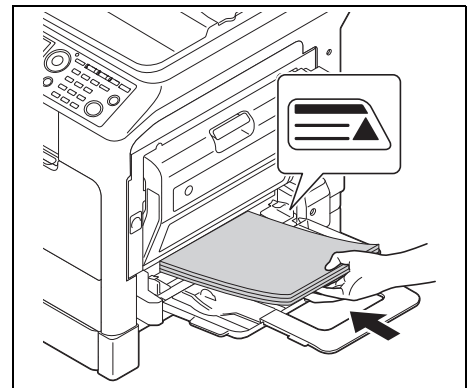

- 2 Adjust the guide and the **Bypass Tray Extension** to fit the paper size.

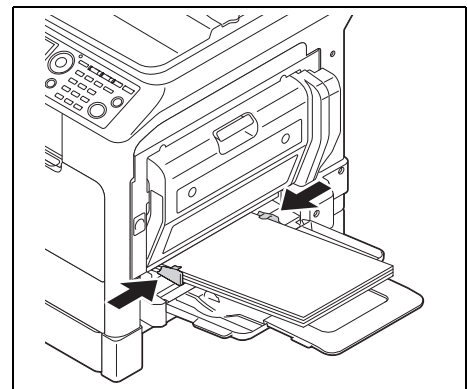

Reference



For details on how to set the size and type of paper, refer to Steps 4 to 7 in page 4-13.

4.4.4 Loading OHP transparencies into Bypass Tray

Up to 10 OHP transparencies can be loaded into the **Bypass Tray**.

NOTICE

If you load OHP transparencies, set the size and type of paper on the **Control Panel**.

- 1 With the print side facing down, load OHP transparencies in the  or  direction to fit the original.

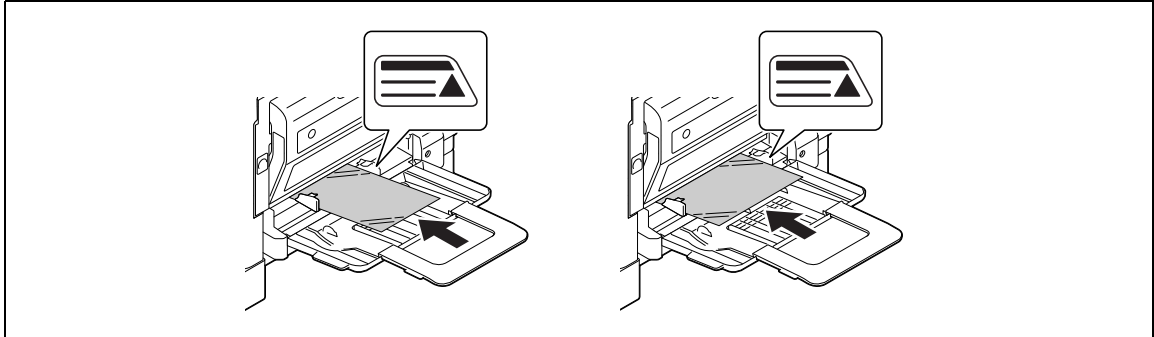

- Do not load the OHP transparencies up to the point where the top of the stack is higher than the ▲ mark.



Reference

For details on how to set the size and type of paper, refer to Steps 4 to 7 in page 4-13.

4.4.5 Loading envelopes into the Bypass Tray

Up to 10 envelopes can be loaded into the **Bypass Tray**.

NOTICE

When loading envelopes, expel air from the envelopes, then hold the folds of the envelopes.

If air is left or the folds are not held firmly, they get wrinkled or a paper jam may occur.

If you load envelopes, set the size and type of paper on the **Control Panel**.

- 1 With the flap part facing up, and load envelopes into the **Bypass Tray**.

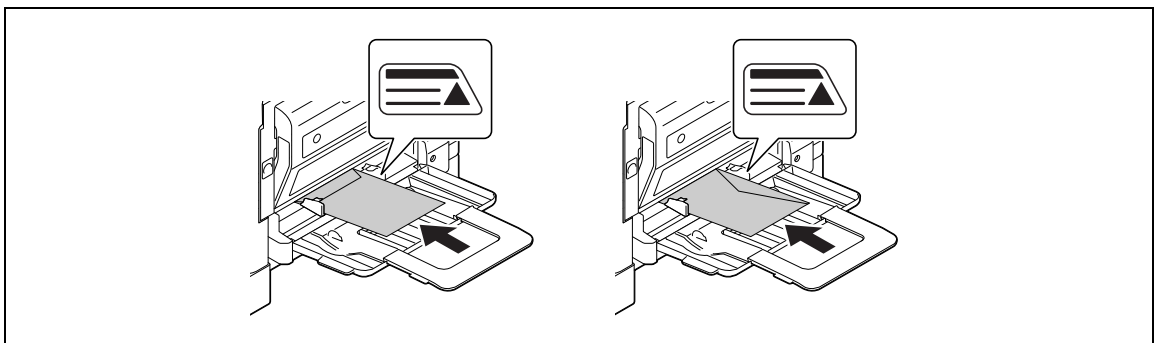

- Do not load the envelopes up to the point where the top of the stack is higher than the ▲ mark.



Reference

For details on how to set the size and type of paper, refer to Steps 4 to 7 in page 4-13.

NOTICE

Do not load envelopes in the  direction.

Do not load envelopes with the flap side down.

Do not load envelopes with the flap side placed as the trailing edge.

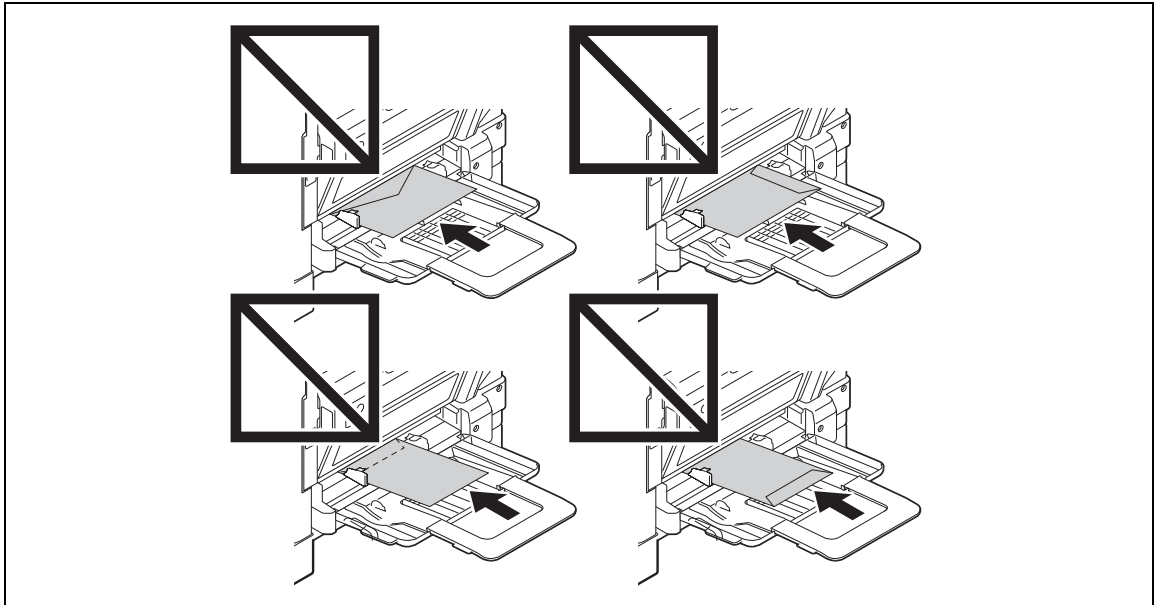

4.4.6 Manually making copies (Bypass Tray)

NOTICE

Be sure to uncurl thick paper before loading it.

- 1 Load the original.
→ For details on how to load the original, refer to page 3-12.
- 2 Load the paper with the side you want to copy facing down, and slightly insert it until it stops.
A screen for paper setup appears.
- 3 Adjust the guide and the **Bypass Tray Extension** to fit the paper size.
- 4 Use the ▲/▼ key to select [SIZE], then press the ► key.
- 5 Use the ▲/▼ key to select the appropriate paper size, then press the **OK** key.

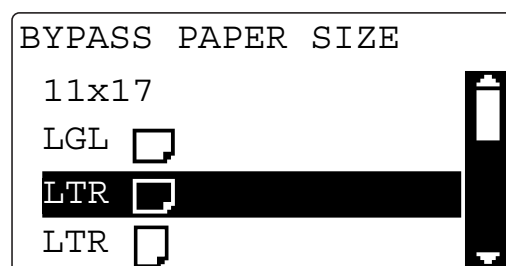

The screen returns to the one for paper setup.

- 6 Use the ▲/▼ key to select [TYPE], then press the ► key.

- 7 Use the ▲/▼ key to select the appropriate paper type, then press the **OK** key.
- Paper type can be selected from [PLAIN], [RECYCLE], [1-SIDE], [SPECIAL], [TRANSPARENCY], [CARD1], [CARD2], [ENVELOPE], [PLAIN 2-SIDE], [CARD1 2-SIDE], [CARD2 2-SIDE], and [RECY. 2-SIDE].

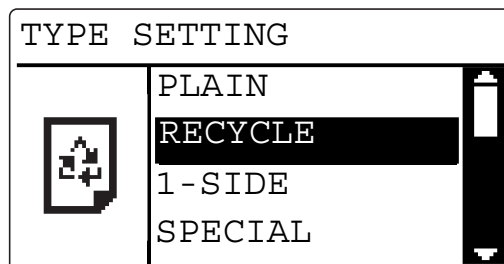



The screen returns to the one for paper setup.

- 8 Press the **Back** key.
- When you want to change the size or type settings, take out the set paper and repeat Step 2 to 8.
- 9 Configure other desired settings.
- For details on the basic functions, refer to page 4-3.
 - For details on the Application, refer to page 5-3.
- 10 Press the **Start** key.







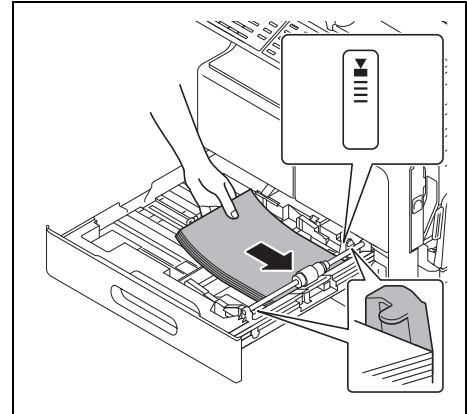

4.5 Making copies on various types of paper

4.5.1 Making copies on OHP transparencies





As an example, this section describes procedures for loading OHP transparencies into **Tray1** and copying the original on them.

- 1 Load the original of 8-1/2 × 11 (A4) size.
 - For details on how to load the original, refer to page 3-12.
- 2 Adjust the guide of **Tray1**, and load OHP transparencies.
 - When loading OHP transparencies in the  or  direction to fit the original.
 - Up to 10 OHP transparencies can be loaded.
 - Be sure to load the OHP transparencies below the tab, so that the stack height does not exceed the  mark.

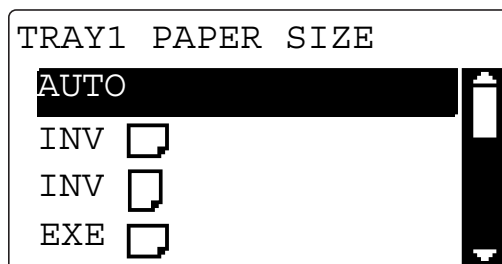

- 3 Press the **Utility** key.
The Utility screen appears.
- 4 Use the / key to select [PAPER SOURCE SETUP], then press the **OK** key.
- 5 Use the / key to select [TRAY1], then press the **OK** key.
- 6 Use the / key to select [PAPER SIZE], then press the **OK** key.
- 7 Use the / key to select [AUTO], then press the **OK** key.



- 8 Use the / key to select [TRAY1], then press the **OK** key.
- 9 Use the / key to select [PAPER TYPE], then press the **OK** key.

- 10 Use the ▲/▼ key to select [TRANSPARENCY], then press the **OK** key.

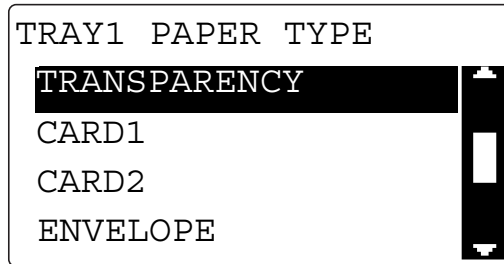

- 11 Press the **Back** key to return to the basic screen.
- 12 Configure other desired settings.
- For details on the basic functions, refer to page 4-3.
 - For details on the Application, refer to page 5-3.
- 13 Press the **Start** key.

4.5.2 Making copies on custom size paper

As an example, this section describes procedures for loading paper of custom size of 150 mm × 200 mm into the **Bypass Tray** and copying the original on the paper.

Tips

Measure the size of originals or paper of custom size before loading them. It will be convenient to use the **Original Scale**.

- 1 Load the original.
 - For details on how to load the original, refer to page 3-12.
- 2 Adjust the guide of the **Bypass Tray**, and load paper.
 - Load the paper so that the side to be copied is facing down.
 - Up to 100 sheets can be loaded into the **Bypass Tray**. Do not load the sheets up to the point where the top of the stack is higher than the ▲ mark.A screen for paper setup appears.
- 3 Use the ▲/▼ key to select [SIZE], then press the ► key.
- 4 Use the ▲/▼ key to select [SIZE INPUT], then press the **OK** key.

- 5 Use the **Keypad** to enter "150" as the length (X), then press the **OK** key.
- Enter the paper length (X) within the range from 140 mm to 432 mm.
 - To correct the entered value, press the **Clear/Stop** key.

```

BYPASS PAPER SIZE
X=150 (140-432)  ✕
Y= 90 ( 90-297)  ← □ ▽
Input=10key (Fin.=OK)
  
```

- Enter the length (X) and width (Y) of the paper correctly.

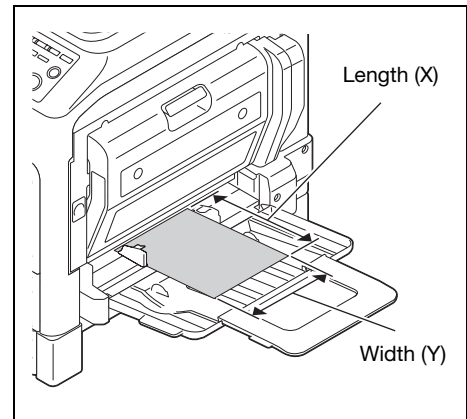

- 6 Use the **Keypad** to enter "200" as the width (Y), then press the **OK** key.
- Enter the paper width (Y) within the range from 90 mm to 297 mm.
 - To correct the entered value, press the **Clear/Stop** key.

```

BYPASS PAPER SIZE
X=150 (140-432)  ✕
Y=200 ( 90-297)  ← □ ▽
Input=10key (Fin.=OK)
  
```

The screen returns to the one for paper setup.

- 7 Confirm that [TYPE:PLAIN] is displayed.
- If paper type other than plain paper is set, select [TYPE], then [PLAIN].
- 8 Press the **Back** key to return to the basic screen.
- 9 Configure other desired settings.
- For details on the basic functions, refer to page 4-3.
 - For details on the Application, refer to page 5-3.
- 10 Press the **Start** key.

4.5.3 Making copies on envelopes

As an example, this section describes procedures for loading envelopes into the **Bypass Tray** and copying the original on them.

Tips

Measure the size of originals or paper of custom size before loading them. It will be convenient to use the **Original Scale**.

- 1 Load the original.
 - For details on how to load the original, refer to page 3-12.
- 2 Adjust the guide of the **Bypass Tray**, and load envelopes.
 - Load the envelopes with the flap side up, so that the side on which you want to copy the original is facing down.
 - When loading envelopes, expel air from the envelopes, then hold the folds of the envelopes.
 - Up to 10 envelopes can be loaded into the **Bypass Tray**. Do not load the envelopes up to the point where the top of the stack is higher than the ▲ mark.

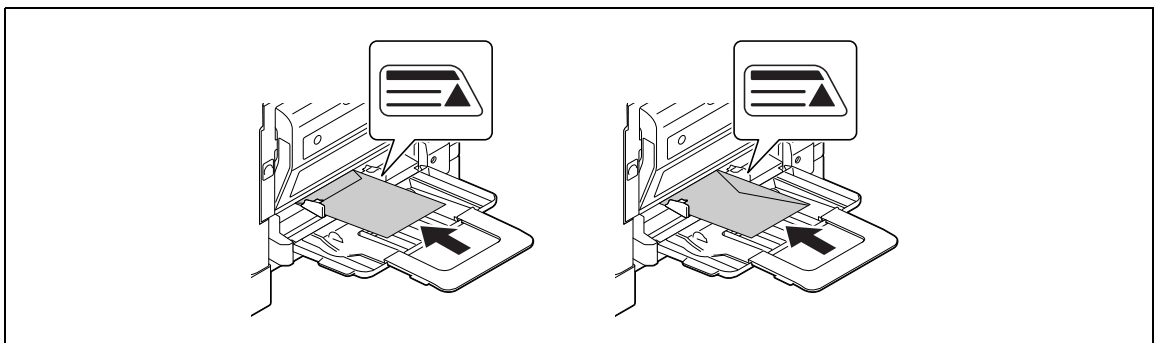

- For details on how to enter the size, refer to page 4-16.
- A screen for paper setup appears.

- 3 Use the ▲/▼ key to select [TYPE], then press the ► key.
- 4 Use the ▲/▼ key to select [ENVELOPE], then press the **OK** key.

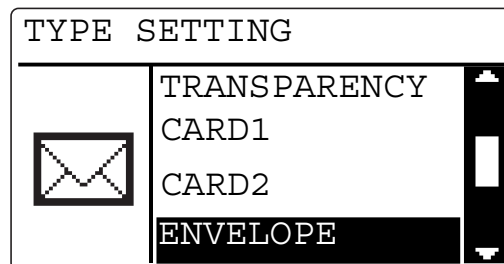

- 5 Press the **Back** key to return to the basic screen.
- 6 Configure other desired settings.
 - For details on the basic functions, refer to page 4-3.
 - For details on the Application, refer to page 5-3.
- 7 Press the **Start** key.

4.6 Specifying the zoom ratio to copy the original

By specifying the zoom ratio, you can copy data larger or smaller than the original size.

4.6.1 Zoom ratio setting type

Zoom ratio type	Description
[AUTO]	The most appropriate zoom ratio is automatically selected based on the size of the loaded original and the selected paper.
[FIXED]	The most appropriate frequently used zoom ratio when copying a standard size original onto paper of a different standard size is set. <Inch area> 25% 50% 64% (11 × 17 → LTR (8-1/2 × 11)) 78% (LGL (8-1/2 × 14) → LTR (8-1/2 × 11)) 100% (same size as the original) 121% (LGL (8-1/2 × 14) → 11 × 17) 129% (LTR (8-1/2 × 11) → 11 × 17) 200% 400% <Metric area> 25% 50% 70% (A3 → A4, B4 → B5) 81% (B4 → A4) 100% (Same size as the original) 115% (B4 → A3) 141% (B5 → B4, A4 → A3) 200% 400%
[MANUAL]	Specify the zoom ratio between 25% and 400%. Directly enter the zoom ratio on the Keypad , Pressing the ▲/▼ key increases or decreases the zoom ratio in steps of 1%.
[X/Y ZOOM]	Copies data with different zoom ratios in width and length directions of the original. Width direction: Specify the zoom ratio between 50% and 200%. Length direction: Specify the zoom ratio between 50% and 100%. Directly enter the zoom ratio on the Keypad ,

4.6.2 Setting the auto zoom function

- 1 Load the original.
→ For details on how to load the original, refer to page 3-12.
- 2 Press the **Zoom** key.
- 3 Use the ▲/▼ key to select [AUTO], then press the **OK** key.
- 4 Configure other desired settings.
→ For details on the basic functions, refer to page 4-3.
→ For details on the Application, refer to page 5-3.
- 5 Press the **Start** key.

Tips

The auto zoom setting and the auto paper setting, the mixed original setting, the book separation copy setting, the ID copy setting, or the 2 in 1/4 in 1 copy setting cannot be set at the same time.

4.6.3 Setting the fixed zoom ratio

- 1 Load the original.
→ For details on how to load the original, refer to page 3-12.
- 2 Press the **Zoom** key.
- 3 Use the ▲/▼ key to select [FIXED], then press the **OK** key.
- 4 Use the ▲/▼ key to select the zoom ratio, then press the **OK** key.

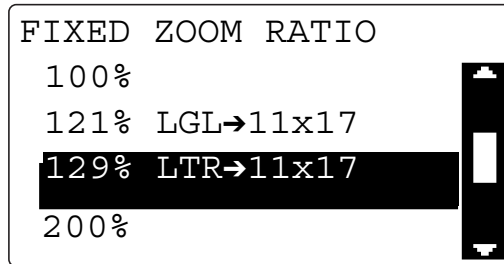

- 5 Configure other desired settings.
→ For details on the basic functions, refer to page 4-3.
→ For details on the Application, refer to page 5-3.
- 6 Press the **Start** key.

Tips

The fixed zoom setting and the ID copy setting or the 2 in 1/4 in 1 copy setting cannot be set at the same time.

4.6.4 Setting the zoom ratio manually

- 1 Load the original.
→ For details on how to load the original, refer to page 3-12.
- 2 Press the **Zoom** key.
- 3 Use the ▲/▼ key to select [MANUAL], then press the **OK** key.
- 4 Use the ▲/▼ key or the **Keypad** to set the zoom ratio, then press the **OK** key.
→ If you use the ▲/▼ key to set the zoom ratio, you can set it in steps of 1%.

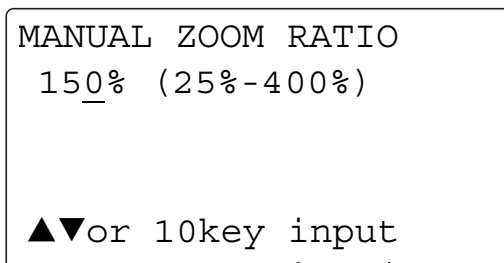

- 5 Configure other desired settings.
→ For details on the basic functions, refer to page 4-3.
→ For details on the Application, refer to page 5-3.
- 6 Press the **Start** key.

 **Tips**

The manual zoom setting and the mixed original setting, the ID copy setting, or the 2 in 1/4 in 1 copy setting cannot be set at the same time.

4.6.5 Setting the X/Y variable zoom ratio

- 1 Load the original.
→ For details on how to load the original, refer to page 3-12.
- 2 Press the **Function** key.
The copy function screen appears.
- 3 Use the ▲/▼ key to select [X/Y ZOOM], then press the **OK** key.
- 4 Use the ▲/▼ key to select [ON], then press the ► key.
- 5 Use the **Keypad** to specify the zoom ratio in the length direction (X), then press the **OK** key.
To correct the entered zoom ratio, press the **Clear/Stop** key, and configure the setting again.

```
X/Y ZOOM SETTING
X= 70 (50-100)  →×
Y=100 (50-200)  ↵↓□
Input=10key (Fin.=OK)
```

- 6 Use the **Keypad** to specify the zoom ratio in the width direction (Y), then press the **OK** key.
To correct the entered zoom ratio, press the **Clear/Stop** key, and configure the setting again.

```
X/Y ZOOM SETTING
X= 70 (50-100)  →×
Y=120 (50-200)  ↵↓□
Input=10key (Fin.=OK)
```

- 7 Press the **Back** key to return to the basic screen.
- 8 Configure other desired settings.
→ For details on the basic functions, refer to page 4-3.
→ For details on the Application, refer to page 5-3.
- 9 Press the **Start** key.

 **Tips**

The X/Y variable zoom ratio setting and the auto paper setting, the mixed original setting, the ID copy setting, or the 2 in 1/4 in 1 copy setting cannot be set at the same time.

4.7 Changing copy density to copy the original

Setting the original type and copy density

Mode	Description
Text mode	Select this mode to copy text originals. The text shape is enhanced to provide the sharp text with clarity. Automatic density adjustment (AUTO) and manual 9-level density adjustment (MANUAL) are available. AUTO: Automatically adjusts the density to fit the original to be copied. MANUAL: Adjust the density by using the ◀ key (lighter) or the ▶ key (darker) to fit the original to be copied.
Photo mode	Select this mode when copying the original with many halftones such as photos. The auto density adjustment is not available in the photo mode.
Text/Photo mode	Select this mode for the original with texts and photos. Automatic density adjustment (AUTO) and manual 9-level density adjustment (MANUAL) are available. AUTO: Automatically adjusts the density to fit the original to be copied. MANUAL: Adjust the density by using the ◀ key (lighter) to prevent background prints when copying newspapers or magazines. When you want reproduce subtle colors in the light part of the image, adjust the density by using the ▶ key (darker).

Tips

If you set the density to the "darker" side in the manual density adjustment mode, the background color may be also copied, and if you set it to the "lighter" side, the copy itself may become lighter. Set an appropriate density level for the original.

4.7.1 Setting the copy density

Tips

If you set [PHOTO] for image quality, automatic setting is not available.

- 1 Load the original.
 - For details on how to load the original, refer to page 3-12.
- 2 Press the **Density** key.
 - A screen that specifies the density appears.
- 3 Use the ▲/▼ key to select [AUTO] or [MANUAL].
 - If you select [AUTO], press the **OK** key.
 - If you select [MANUAL], use the ◀/▶ key to select a density from nine levels, then press the **OK** key.



The screen returns to the basic screen.

- 4 Configure other desired settings.
 - For details on the basic functions, refer to page 4-3.
 - For details on the Application, refer to page 5-3.
- 5 Press the **Start** key.



Making Copies in Advanced Manner

5 Making Copies in Advanced Manner

5.1 Finishing setting (sorting, grouping)

When copying or printing two or more sets, you can copy each set in order of page (Sort) or make copies by page (Group).

5.1.1 Finishing type

Non-sort:

Copies the original without sorting them.

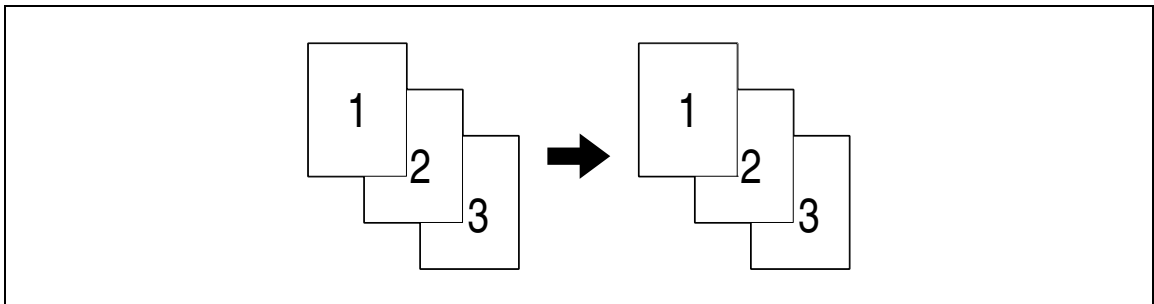

Sort:

Automatically sorts and copies a multi-page original per set.

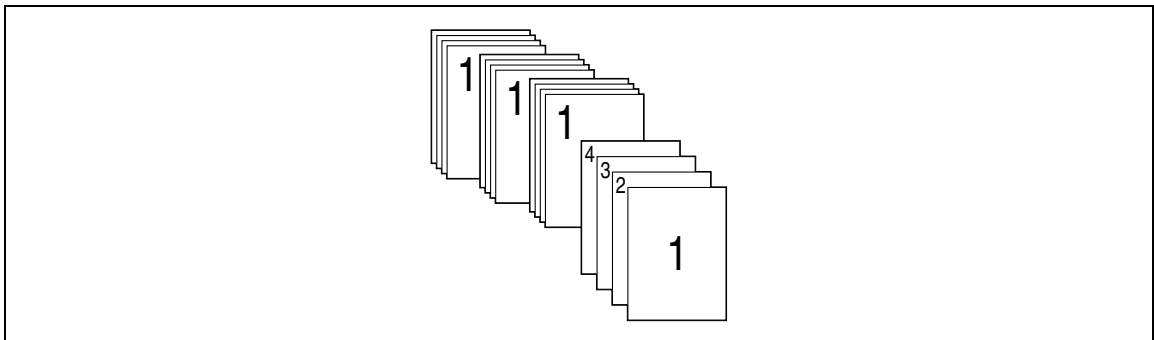

Group:

Sorts and copies a multi-page original per page.

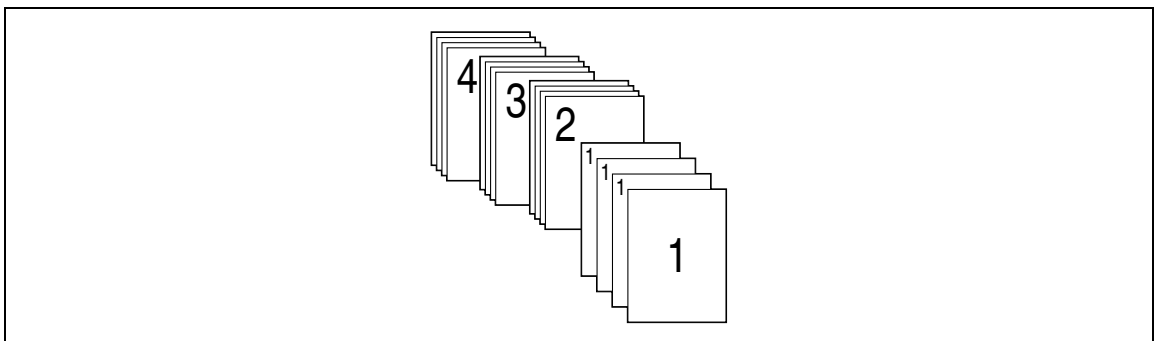

Alternate Sort:

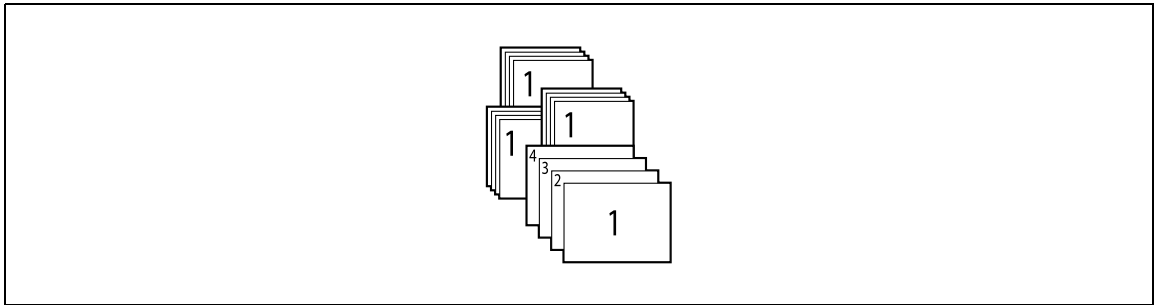

Sorts an original by outputting paper of  and  alternately per set.

**Alternate Group:**

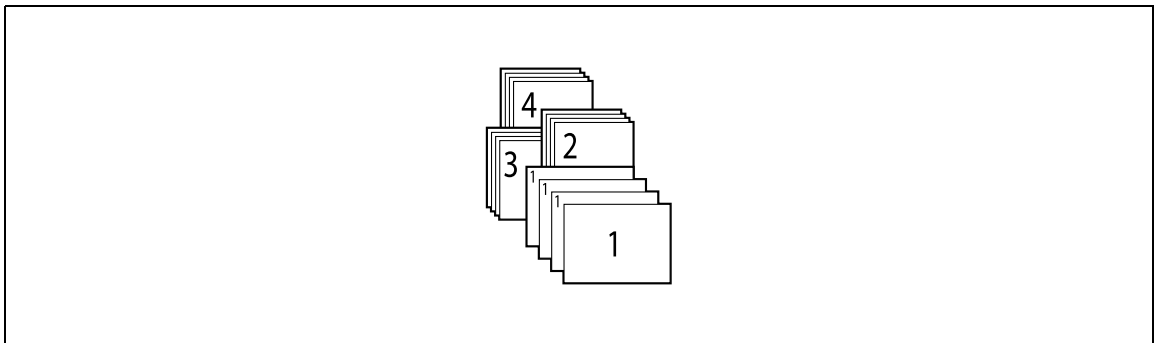
Sorts an original by outputting paper of  and  alternately per page.



 **Tips**

To output paper alternately, the following conditions are required.

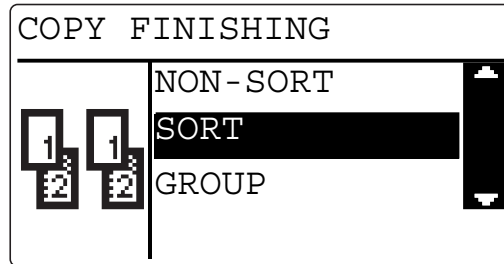

- 8-1/2 × 11 (A4) or B5 size paper is used.
Paper of the same size and type is loaded with the  orientation in one paper tray and with the  orientation in another tray.
Auto Paper is set.
Mixed Original is not set.
Book Separation is not set.
In the Utility menu, [CRISSCROSS MODE] is set to [ON]. (For details, refer to page 6-33.)

5.1.2 Setting finishing

- 1 Load the original.
→ For details on how to load the original, refer to page 3-12.
- 2 Press the **Finishing** key.
A screen that specifies the finishing appears.
- 3 Use the ▲/▼ key to select [NON-SORT], [SORT], or [GROUP], then press the **OK** key.



The following icons are displayed in the basic screen.

- When [SORT] is selected,  is shown.
- When [GROUP] is selected,  is shown.

- 4 Configure other desired settings.
→ For details on the basic functions, refer to page 4-3.
→ For details on the Application, refer to page 5-3.
- 5 Use the **Keypad** to specify the number of copies, then press the **Start** key.
→ If you set the original on the **Original Glass**, the number of scans is displayed under [NEXT PAGE?] and the number of copies. Set the next original and press the **OK** key. Repeat this operation the same number of times as there are originals. When all pages have been scanned, press the **Start** key.



Tips

If the optional **Reverse Automatic Document Feeder DF-625** is not installed, [GROUP] will not be displayed.

5.2 Making 1-sided or 2-sided copy

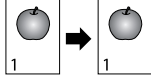
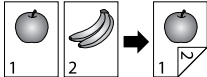
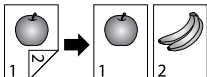
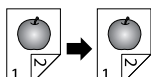
The Simplex/Duplex function is available in the following four settings: 1-sided to 1-sided setting, 1-sided to 2-sided setting, 2-sided to 1-sided setting, or 2-sided to 2-sided setting.

Name	Functions
[1-SIDE → 1-SIDE]	Prints a 1-sided original on one side of paper. 
[1-SIDE → 2-SIDE]	Prints a 1-sided original on two sides of paper. 
[2-SIDE → 1-SIDE]	Prints a 2-sided original on one side of paper. 
[2-SIDE → 2-SIDE]	Prints a 2-sided original on two sides of paper. 

- 1 Load the original.
→ For details on how to load the original, refer to page 3-12.
- 2 Press the **Simplex/Duplex** key.
A screen for specifying the 2-sided/1-sided copy appears.
- 3 Use the **▲/▼** key to select [1-SIDE → 1-SIDE], [1-SIDE → 2-SIDE], [2-SIDE → 1-SIDE], or [2-SIDE → 2-SIDE], then press the **OK** key.
The following icons are displayed in the basic screen.
→ When [1-SIDE → 2-SIDE] is selected,  is shown.
→ When [2-SIDE → 1-SIDE] is selected,  is shown.
→ When [2-SIDE → 2-SIDE] is selected,  is shown.

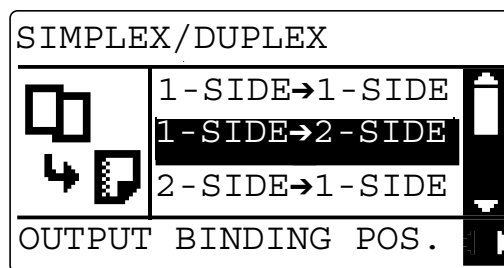

- When you select [1-SIDE → 2-SIDE] and press the **▶** key, you can specify the binding position for the printed sheets. Select [LEFT], [RIGHT], or [TOP], then press the **OK** key.
- When you select [2-SIDE → 1-SIDE] and press the **▶** key, you can specify the binding position for the original. Select [LEFT], [RIGHT], or [TOP], then press the **OK** key.
- When you select [2-SIDE → 2-SIDE] and press the **▶** key, you can specify the binding position for the original. When you press the **▶** key next, you can specify the binding position for the printed sheets. press the **OK** key.

- 4 Configure other desired settings.
 - For details on the basic functions, refer to page 4-3.
 - For details on the Application, refer to page 5-3.
- 5 Use the **Keypad** to specify the number of copies, then press the **Start** key.
 - If you set the original on the **Original Glass**, the number of scans is displayed under [NEXT PAGE?] and the number of copies. Set the next original and press the **OK** key. Repeat this operation the same number of times as there are originals. When all pages have been scanned, press the **Start** key.

 **Tips**

- If the optional **Reverse Automatic Document Feeder DF-625** is not installed, [2-SIDE → 1-SIDE] [2-SIDE → 2-SIDE] will not be displayed.
- The 1side → 1side setting and ID copy setting cannot be set at the same time.
- The 1side → 2side setting and the mixed original setting or ID copy setting cannot be set at the same time.
- The 2side → 1side setting or the 2side → 2side setting and the book separation setting or ID copy setting cannot be set at the same time.

5.3 Configuring 2in1 or 4in1 copy settings

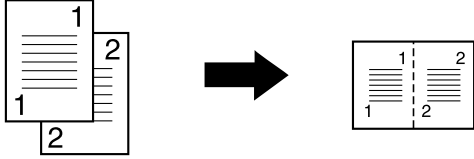
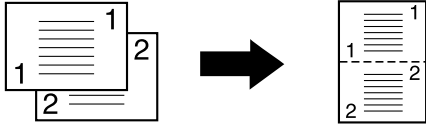
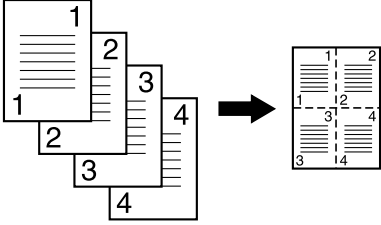
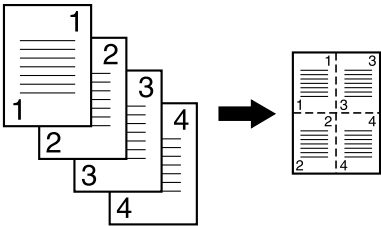
Name	Functions
[2 in 1]	<p data-bbox="603 264 1315 320">Copies images on two original pages on one sheet of paper. If the originals are portrait, they are output horizontally-combined.</p>  <p data-bbox="603 506 1315 539">If the originals are landscape, they are output vertically-combined.</p> 
[4 in 1]	<p data-bbox="603 736 1422 819">Copies images of four original pages on one sheet of paper. When [PATTERN1] is selected, the originals are output combined in the order of upper left, upper right, lower left, and lower right.</p>  <p data-bbox="603 1077 1422 1133">When [PATTERN2] is selected, the originals are output combined in the order of upper left, lower left, upper right, and lower right.</p> 

- 1 Load the original.
 - For details on how to load the original, refer to page 3-12.
- 2 Press the **Combine Original** key.

The screen for setting up the 2in1 and 4in1 appears.
- 3 Use the ▲/▼ key to select [2in1] or [4in1], then press the **OK** key.
 - When you select [2in1] and press the ► key, you can specify the original direction. For details on the original direction, refer to page 4-6.
 - When you select [4in1] and press the ► key, you can specify the page order. Select [PATTERN1] or [PATTERN2], then press the **OK** key. When you press the ► key next, you can specify the original direction.

Pattern 1

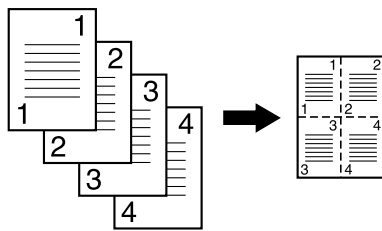

Pattern 2

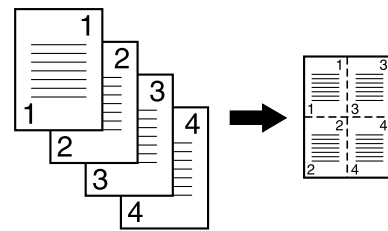

- 4 Configure other desired settings.
 - For details on the basic functions, refer to page 4-3.
 - For details on the Application, refer to page 5-3.
 - If you set multiple sets, press the **Finishing** key and select [SORT].
- 5 Use the **Keypad** to specify the number of copies, then press the **Start** key.
 - If you set the original on the **Original Glass**, the number of scans is displayed under [NEXT PAGE?] and the number of copies. Set the next original and press the **OK** key. Repeat this operation the same number of times as there are originals. When all pages have been scanned, press the **Start** key.

Tips

The 2 in 1/4 in 1 copy setting and the manual zoom setting, the X/Y variable zoom ratio setting, the mixed original setting, the book separation copy setting, the ID copy setting, the page margin setting, or the erase setting cannot be set at the same time.

5.4 Using the ID Copy

Separately scans the contents of the front and back sides of a card, for example, insurance card, driver's license, or business card, and copies them together on one sheet.

Using the ID copy function, you can save the number of sheets to be used.

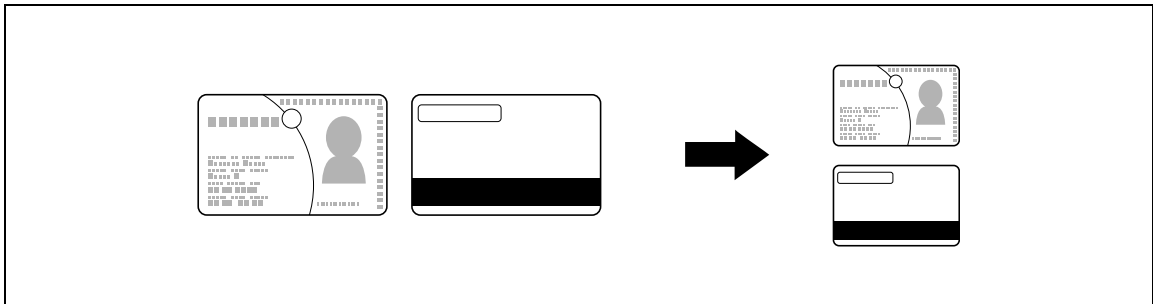

- Set the original at a distance $\frac{3}{16}$ inches (4 mm) away from the **Original Scale** on the left and at the top of the **Original Glass**.

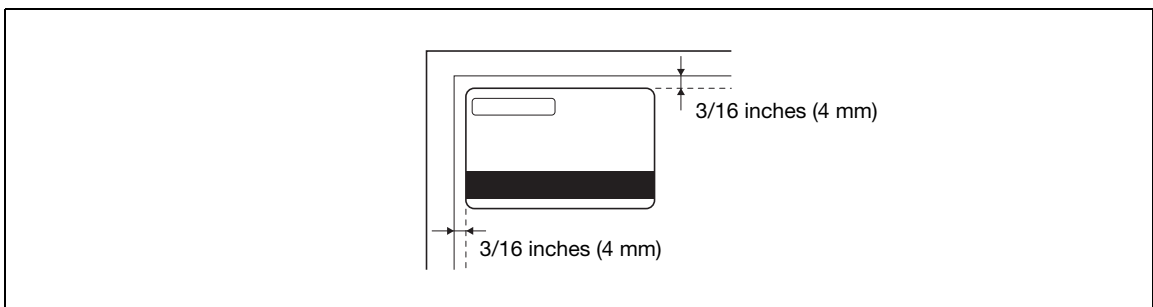

- 1 Open the **ADF**, and set the original on the Original Glass with the front side of the card facing down.
- 2 Press the **ID Copy** key.
 is displayed in the basic screen.
- 3 Use the **Keypad** to specify the number of copies, then press the **Start** key.
 The number of scanned pages is displayed under [NEXT PAGE?] and the number of copies.
 → When copying only the front side of the card, press the **Start** key.
- 4 Open the **ADF**, and set the original on the Original Glass with the back side of the card facing down, then press the **OK** key.

Tips

- If you press the **ID Copy** key, [TEXT/PHOTO] is automatically selected as copy quality.
- To change the copy quality, press the **Quality** key before pressing the **Start** key.

The ID copy setting and the auto paper setting, the zoom setting, the mixed original setting, the book separation copy setting, the 2-sided copy setting, the 2 in 1/4 in 1 copy setting, the page margin setting, or the erase setting cannot be set at the same time.

5.5 Making copies by entering the ID (Account) number

If you register the ID (Account) number, you can configure settings so that only specific users can use this machine or you can manage the number of copies by account.

This section describes procedure for entering the ID (Account) number and making copies.

- ✓ If you have registered the ID (Account) number, you cannot use this machine unless you enter it before using this machine.
- ✓ To use this function, select [ADMIN. MANAGEMENT] and [ACCOUNT TRACK] in the Utility menu, and configure setting. For details, refer to page 6-20.

- 1 Enter the 3-digit ID (Account) number using the **Keypad**.

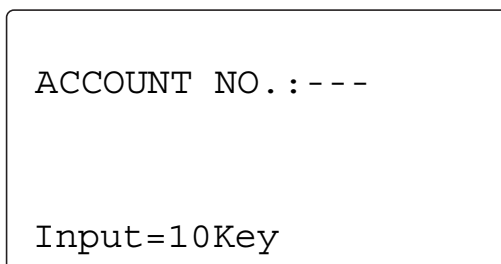

→ To correct the ID (Account) number, press the **Clear/Stop** key.

- 2 Press the **Access** key.

The screen switches from the screen for inputting the ID to the basic screen, and you can make copies.

- 3 Load an original and configure copy settings.

→ For details on the basic functions, refer to page 4-3.

→ For details on the Application, refer to page 5-3.

- 4 Press the **Start** key.

- 5 When the copy operation completes, press the **Access** key again.

The screen for entering the ID (Account) appears.

Tips

If the auto panel reset time has elapsed, the screen for entering the ID (Account) appears.

5.6 Setting book separation copy

Divides or does not divide page spreads (such as a book or catalog) into left and right pages to copy data.

If you combine this function with the erase function, you can erase the area outside the original and the folds when making copies.

Confirm the size and orientation of the paper in the paper tray in advance.

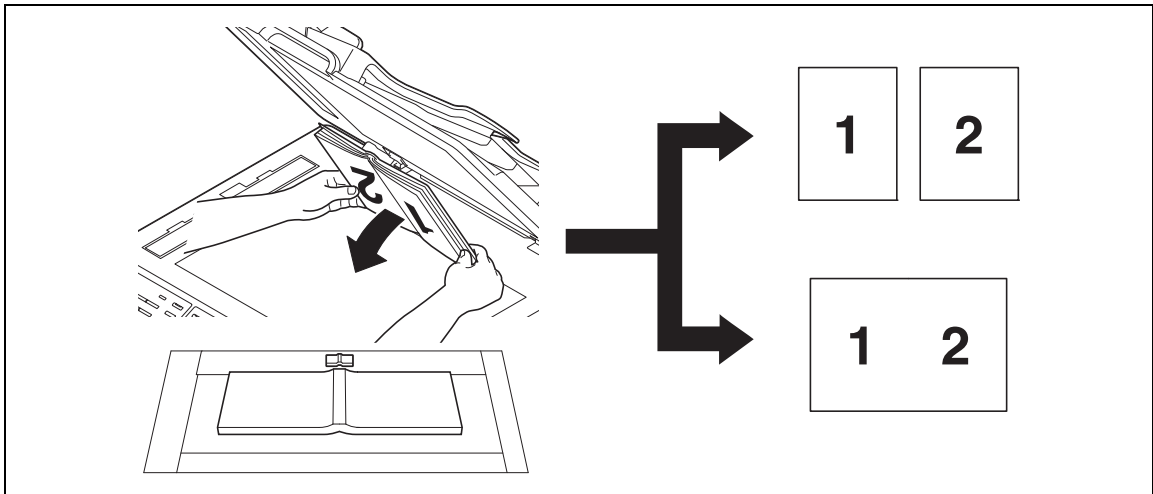

- 1 Set the original onto the **Original Glass**.
→ Set the original along the mark at the center of the **Original Glass**.
- 2 Press the **Function** key.
The copy function screen appears.
- 3 Use the ▲/▼ key to select [BOOK SEP.], then press the **OK** key.
- 4 Use the ▲/▼ key to select [SEPARATION] or [SPREAD], then press the **OK** key.

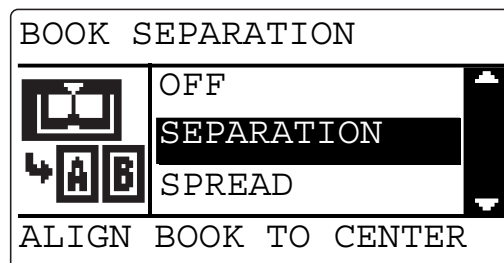

- [SEPARATION]: Copy the right and left pages of two-page spreads separately in the order of the page numbers.
 - [SPREAD]: Copy a two-page spread as one page.
 - When specifying the erase function, go to the next step. When not specifying the erase function, skip to Step 8.
 - If you separate data when making copies, the data on the left page is copied first when the set original is left bound, and the data on the right page is copied first when it is right bound. The binding position can be changed at [BINDING POSITION] in the Utility menu. For details, refer to page 6-28.
- 5 Use the ▲/▼ key to select [ERASE], then press the **OK** key.

- 6 Use the ▲/▼ key to select [FRAME], [CENTER], or [CENTER+FRAME], then press the **OK** key.

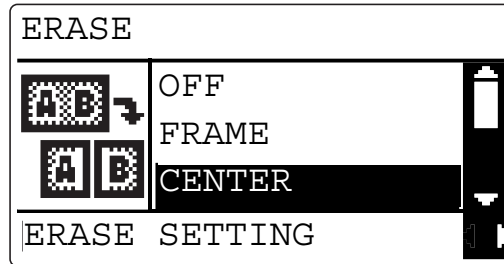

→ If you select [FRAME], [CENTER], or [CENTER+FRAME] and press the ► key, you can specify the erase width. You can set the erase width for CENTER within the range from 2 mm to 30 mm, and the erase width for FRAME within the range from 4 mm to 20 mm in steps of 1 mm. Press the **OK** key.

- 7 Press the **Back** key to return to the basic screen.

 is displayed in the basic screen.

- 8 Configure other desired settings.

→ For details on the basic functions, refer to page 4-3.
→ For details on the Application, refer to page 5-3.

- 9 Use the **Keypad** to specify the number of copies, then press the **Start** key.

Tips

The book separation copy and the auto zoom setting, the auto paper setting, 2side → 1side/2side → 2side copy setting, the mixed original setting, ID copy setting, 2 in 1/4 in 1 copy setting cannot be set at the same time.

5.6.1 Frame/Center erase type

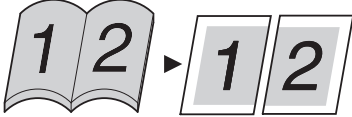
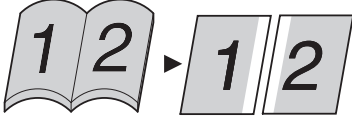
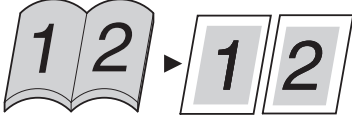
Erase type	Description
[FRAME]	Erases the area outside the original and copy data. 
[CENTER]	Erases the center area of the original and copy data. 
[CENTER + FRAME]	Erases the area to the outside and center of the original and copy data. 

5.7 Erasing a part of the original and making copies (Erase)

Erases any contamination on the edges of the original and makes copies.

Setting the erase

- 1 Load the original.
→ For details on how to load the original, refer to page 3-12.
- 2 Press the **Function** key.
The copy function screen appears.
- 3 Use the ▲/▼ key to select [ERASE], then press the **OK** key.
- 4 Use the ▲/▼ key to select [LEFT], [UPPER], or [FRAME], then press the **OK** key.

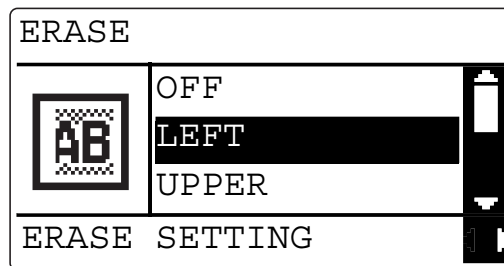

- If you select [LEFT], [UPPER], or [FRAME] and press the ► key, you can specify the erase width. You can set the erase width within the range from 4 mm to 20 mm in steps of 1 mm. Press the **OK** key.

- 5 Press the **Back** key to return to the basic screen.
 is displayed in the basic screen.
- 6 Configure other desired settings.
 → For details on the basic functions, refer to page 4-3.
 → For details on the Application, refer to page 5-3.
- 7 Use the **Keypad** to specify the number of copies, then press the **Start** key.

Tips

- [LEFT] or [UPPER] for [ERASE] and the book separation copy setting, the ID copy setting, or 2 in 1/4 in 1 copy setting cannot be set at the same time.
- [FRAME] for [ERASE] and the ID copy setting or 2 in 1/4 in 1 copy setting cannot be set at the same time.

5.8 Erasing shadows outside the original to copy (Outer Erase)

When making copies with the **ADF** open and the original placed on the **Original Glass**, the machine detects the outline of the original and erases the area outside the original.

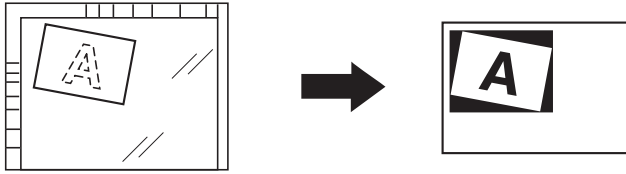
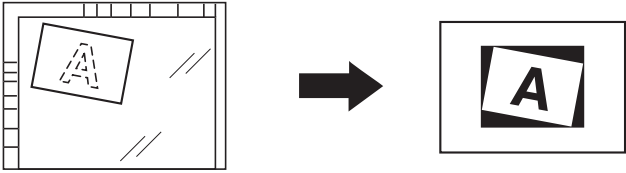
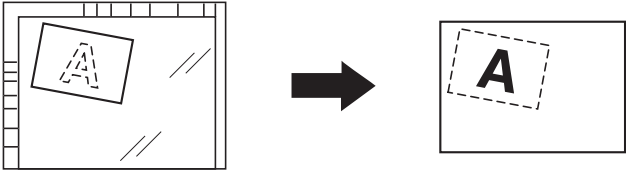
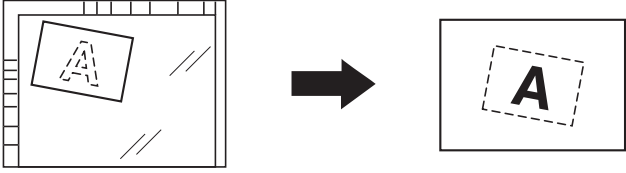
Name	Functions
[RECTANGULAR]	<p>If the background color of the original is dark, it is difficult to identify the border between the original and outside area. Therefore, the machine does not erase the area outside the original (shadow caused by external light) for copying.</p> 
[RCTNGL+CENTER]	<p>The document reading method is the same as that of [RECTANGULAR] and the original is copied on the center of the paper.</p> 
[BEVEL]	<p>If the background color of the original is light, it is easy to identify the border between the original and outside area. Therefore, the machine erases the area outside the original (shadow caused by external light) for copying.</p> 
[BEVEL+CENTER]	<p>The document reading method is the same as that of [BEVEL] and the original is copied on the center of the paper.</p> 

- 1 Set the original in an arbitrary position with the **ADF** or **Original Cover** opened.
- 2 Press the **Function** key.
The copy function screen appears.
- 3 Use the **▲/▼** key to select [OUTER ERASE], then press the **OK** key.
- 4 Use the **▲/▼** key to select [RECTANGULAR], [RCTNGL+CENTER], [BEVEL], or [BEVEL+CENTER], then press the **OK** key.

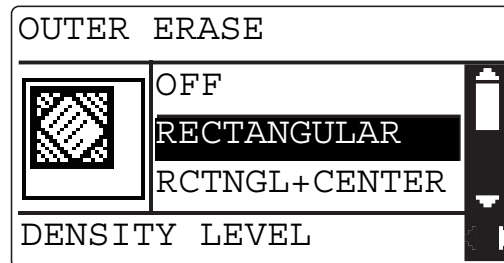

- If you select [RECTANGULAR], [RCTNGL+CENTER], [BEVEL], or [BEVEL+CENTER] and press the **▶** key, you can specify the density level. Use the **◀/▶** key to select the density level, then press the **OK** key.

- 5 Press the **Back** key to return to the basic screen.
 is displayed in the basic screen.
- 6 Configure other desired settings.
 - For details on the basic functions, refer to page 4-3.
 - For details on the Application, refer to page 5-3.
- 7 Use the **Keypad** to specify the number of copies, then press the **Start** key.
 - Originals are scanned twice. Be sure not to move the originals until their copies are output.
 - The paper sizes that are automatically detected are 10 mm × 10 mm or more. If the paper size is not automatically detected, the job is cancelled.
 - The top or rear part of the original image can be missing.

Tips

The outer erase setting and the auto paper setting, the auto zoom setting, 2side → 1side/2side → 2side copy setting, the mixed original setting, the book separation copy setting, ID copy setting, 2 in 1/4 in 1 copy setting, erase setting, Neg./Pos. reverse setting, or stamp setting cannot be set at the same time.

5.9 Making copies with black and white reversed (Neg./Pos. Reverse)

You can make copies by reversing the white part (background) and the black part (text) of the original.

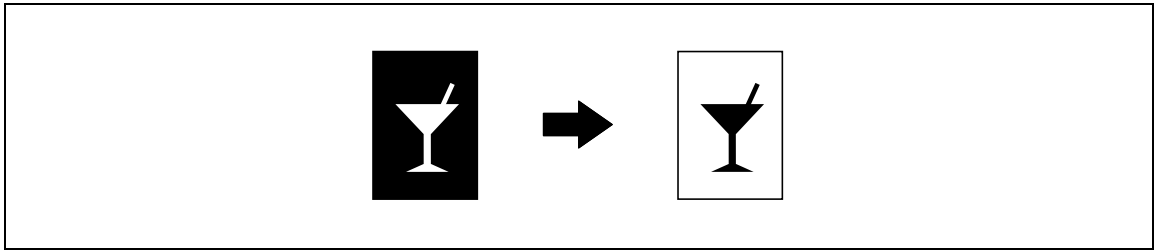

- 1 Load the original.
→ For details on how to load the original, refer to page 3-12.
- 2 Press the **Function** key.
The copy function screen appears.
- 3 Use the ▲/▼ key to select [NEG. ←→ POS.], then press the **OK** key.
- 4 Use the ▲/▼ key to select [ON], then press the **OK** key.

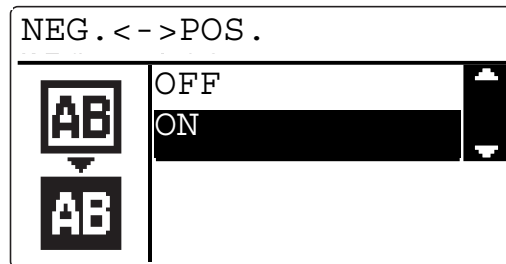

- 5 Press the **Back** key to return to the basic screen.
AB is displayed in the basic screen.
- 6 Configure other desired settings.
→ For details on the basic functions, refer to page 4-3.
→ For details on the Application, refer to page 5-3.
- 7 Use the **Keypad** to specify the number of copies, then press the **Start** key.

5.10 Making copies with a binding margin

You can displace the original image to the right and make copies by setting a binding margin on the left of the paper.

If you set a binding margin for the paper on which you want to copy data, you will be able to easily file the pages.

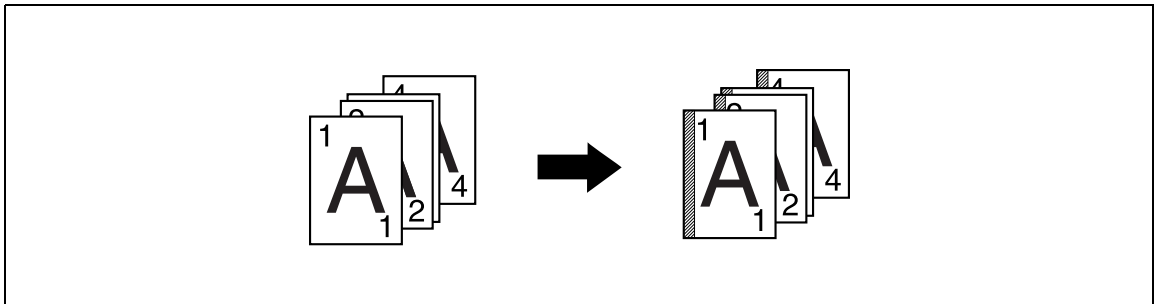

Setting a binding margin

- 1 Load the original.
→ For details on how to load the original, refer to page 3-12.
- 2 Press the **Function** key.
The copy function screen appears.
- 3 Use the ▲/▼ key to select [PAGE MARGIN], then press the **OK** key.
- 4 Use the ▲/▼ key to select [ON], then press the **OK** key.

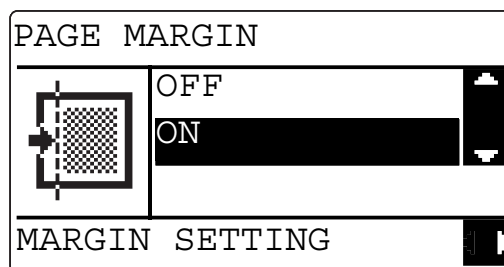

- When you select [ON] and press the ► key, you can specify the binding margin width. You can set the binding margin width within the range from 0 mm to 20 mm in steps of 1 mm. Press the **OK** key.
- 5 Press the **Back** key to return to the basic screen.
⏪ is displayed in the basic screen.
 - 6 Configure other desired settings.
→ For details on the basic functions, refer to page 4-3.
→ For details on the Application, refer to page 5-3.
 - 7 Use the **Keypad** to specify the number of copies, then press the **Start** key.

Tips

The binding margin setting and the ID copy setting or the 2 in 1/4 in 1 copy setting cannot be set at the same time.

5.11 Making copies with a date and page number

You can print the date/time or page number.

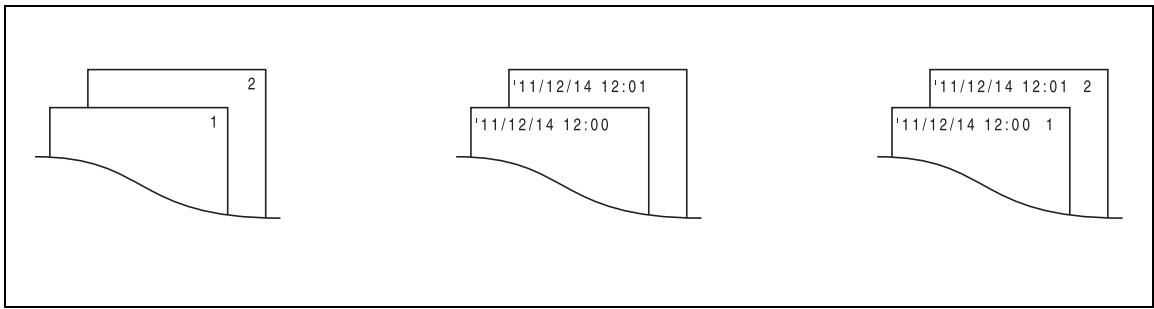

- 1 Press the **Function** key.
The copy function screen appears.
- 2 Use the ▲/▼ key to select [STAMP], then press the **OK** key.
- 3 Use the ▲/▼ key to select [PAGE NUMBER], [DATE&TIME], or [PAGE+D&T], then press the **OK** key.

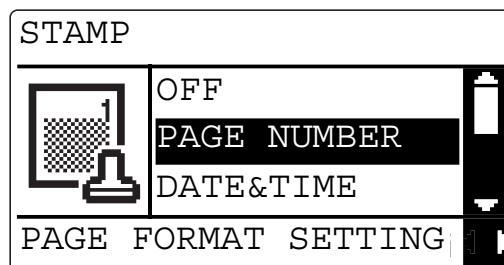

- When you select [PAGE NUMBER] and press the ► key, you can select the page number type. Select [P001, P002,] or [1, 2, 3,], then press the **OK** key.
 - When you select [DATE&TIME] and press the ► key, you can select the date/time type. Select [MM/DD/YY], [DD/MM/YY], or [YY/MM/DD], then press the **OK** key.
 - When you select [PAGE+D&T] and press the ► key, you can select the date/time type. If you press the ► key next, you can select the page number type. Press the **OK** key.
- 4 Press the **Back** key to display the basic screen.
 is displayed in the basic screen.
 - 5 Configure other desired settings.
 - For details on the basic functions, refer to page 4-3.
 - For details on the Application, refer to page 5-3.
 - 6 Use the **Keypad** to specify the number of copies, then press the **Start** key.

5.12 Registering or recalling the copy settings

By registering the frequently used copy mode, you can recall it as required. You can register up to two copy settings.

The available setting items are as follows.

- Number of Copies
- Tray Select (Including [AUTO])
- Image quality
- Density (Including [AUTO])
- Each item of the function (Frame Erase, Page Margin, X/Y Variable Zoom Ratio, Neg./Pos. Reverse, Book Separation)
- Mixed Original
- Combine Originals
- Zoom
- Finishing
- ID Copy
- Stamp

If the paper loaded in the tray is in custom size, it is not registered. For details on registering the custom size, refer to page 6-14.

5.12.1 Registering the copy setting



You cannot register setting while this machine is warming up.

- 1 Set various items you want to register.
 - For details on the basic functions, refer to page 4-3.
 - For details on the Application, refer to page 5-3.
- 2 Press the **Mode Memory** key.
The program screen appears.
- 3 Use the ▲/▼ key to select [REGISTER], then press the **OK** key.
- 4 Use the ▲/▼ key to select the program number to be registered, then press the **OK** key.
The current copy setting is registered.

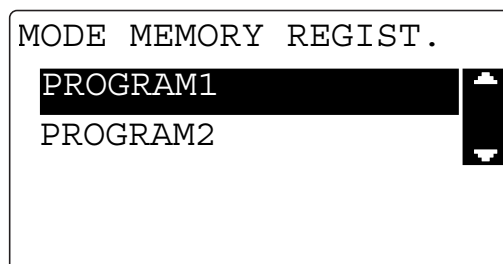

- If you register a new copy setting to a program number for which a program has been already registered, the previous copy setting is erased.

5.12.2 Recalling the copy setting and making copies

- 1 Load the original.
→ For details on how to load the original, refer to page 3-12.
- 2 Press the **Mode Memory** key.
The program screen appears.
- 3 Use the ▲/▼ key to select [RECALL], then press the **OK** key.
- 4 Use the ▲/▼ key to select the program number to be recalled, then press the **OK** key.
The selected program is recalled.

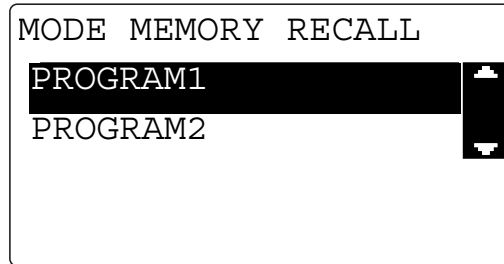

- 5 Press the **Start** key.

A large, bold, black number '6' is centered within a gray square. The square is positioned to the left of the chapter title.

Utility and Copy Settings

6 Utility and Copy Settings

6.1 Utility

The Utility screen provides 14 setting items.

Number	Name	Description	Reference Page
1	[MACHINE SETTING]	Configure the settings for the operating environment of this machine.	p. 6-5
2	[PAPER SOURCE SETUP]	Specify the size and type of the paper loaded in Tray 1 . You can also specify the unit of paper size and paper type loaded in Tray2-Tray5 .	p. 6-11
3	[CUSTOM SIZE MEMORY]	Register up to two custom sizes.	p. 6-14
4	[DRUM DEHUMIDIFY]	Perform maintenance operations to prevent a function reduction.	p. 6-16
5	[ADMIN. MANAGEMENT]	Configure the remote monitor settings or settings for the administrator to manage each account.	p. 6-18
6	[COPY SETTING 1]	Configure the default settings for each copy function.	p. 6-24
7	[COPY SETTING 2]		p. 6-32
8	[DIAL REGISTRATION]	For details, refer to [User's Guide Fax] [User's Guide Scan].	-
9	[FAX REGISTRATION]	This item is available if the optional Fax Kit FK-510 is installed. For details, refer to [User's Guide Fax].	-
10	[FAX TX OPERATION]	This item is available if the optional Fax Kit FK-510 is installed. For details, refer to [User's Guide Fax].	-
11	[FAX RX OPERATION]	This item is available if the optional Fax Kit FK-510 is installed. For details, refer to [User's Guide Fax].	-
12	[REPORTING]	For details, refer to [User's Guide Fax].	-
13	[SCAN SETTING]	For details, refer to [User's Guide Scan].	-
14	[CONFIRM MODE]	Confirm the counter or communication result, or print out a report.	p. 6-37

Tips

Some items cannot be configured depending on which optional device is installed in this machine. If an unavailable item is selected, an error message appears.

6.2 Machine Setting

In the Machine Setting screen, change the settings for the following items.

<Items for Machine Setting>

Number	Settings	Description
1	[AUTO PANEL RESET]	After completing copy operations or the last key operation, set the time period until the auto panel reset function starts from [OFF], [30 sec], [1 min], [2 min], [3 min], [4 min], or [5 min]. The auto panel reset function automatically returns the screen to the initial mode, and the basic screen appears. <ul style="list-style-type: none"> The factory default is [1 min].
2	[SLEEP MODE]	Set the time period until this machine enters sleep mode after the user paused operations within the range from [1 min] to [60 min]. <ul style="list-style-type: none"> The factory default is [15 min].
3	[AUTO SHUT TIME]	Specify whether to automatically turn the power off [ON] or not [OFF] when the specified time elapsed after this machine became inactive. If [ON] is selected, specify the time [15 min] to [240 min] required to turn the power off. <ul style="list-style-type: none"> The factory default is [ON].
4	[DENSITY(ADF)]	Set the image quality level when using the optional ADF . [MODE1]: Select this to make copies with the density same as that of the original. [MODE2]: Select this to set the lighter copy density and prevent contamination due to copying. <ul style="list-style-type: none"> The factory default is [MODE1].
5	[DENSITY(BOOK)]	Set the image quality level when you copy the original by setting it on the Original Glass . [MODE1]: Select this to make copies with the density same as that of the original. [MODE2]: Select this to set the lighter copy density and prevent contamination due to copying. <ul style="list-style-type: none"> The factory default is [MODE1].
6	[PRINT DENSITY]	Adjust copy density. <ul style="list-style-type: none"> The factory default is (□□□□□□□□).
7	[LCD CONTRAST]	Use this dial to adjust the brightness of the LCD Display . <ul style="list-style-type: none"> The factory default is (□□□□□).
8	[KEY SPEED SETTING]	Set the time period until repeating input starts by holding down the key and the interval for repetition to [0.1 sec], [0.3 sec], [0.5sec], [1.0 sec], [1.5 sec], [2.0 sec], [2.5 sec], or [3.0sec]. <ul style="list-style-type: none"> The factory default is Start Time: [1.0 sec] and Interval: [0.1sec].
9	[DOUBLE-STRIKE KEY]	When conducting key operations continuously, set the time interval between the previous operation and the next operation. <ul style="list-style-type: none"> The factory default is [0.0 sec].
10	[LANGUAGE]	Set a display screen language. <ul style="list-style-type: none"> The factory default is [ENGLISH].
11	[BUZZER VOLUME]	This item is available if the optional FAX Kit FK-510 is installed. You can adjust buzzer volume. <ul style="list-style-type: none"> The factory default is [LOW]. For details, refer to [User's Guide Fax].
12	[INITIAL MODE]	This item is available if the optional FAX Kit FK-510 is installed. You can specify the initial mode. <ul style="list-style-type: none"> The factory default is [COPY]. For details, refer to [User's Guide Fax].
13	[SCAN THRESHOLD]	You can set remaining amount of memory when you interrupt to scan the original because the memory becomes full. <ul style="list-style-type: none"> The factory default is [512Kbyte]. For details, refer to [User's Guide Fax].

6.2.1 Select Machine Setting

- 1 Press the **Utility** key.
The Utility screen appears.
- 2 Use the ▲/▼ key to select [MACHINE SETTING], then press the **OK** key.

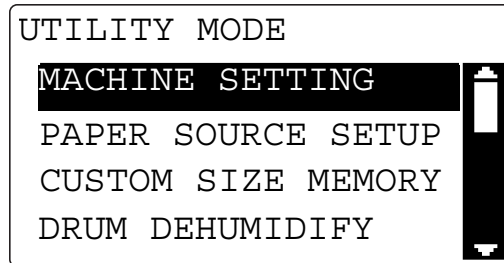

6.2.2 Changing the auto panel reset setting

- 1 Select [MACHINE SETTING].
→ For details on selecting [MACHINE SETTING], refer to page 6-5.
- 2 Use the ▲/▼ key to select [AUTO PANEL RESET], then press the **OK** key.
- 3 Use the ▲/▼ key to select [OFF], [30 sec], [1 min], [2 min], [3 min], [4 min], or [5 min], then press the **OK** key.

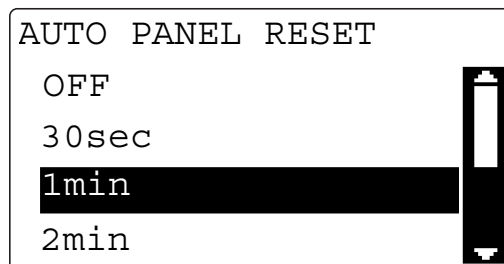

This returns to the Machine Setting screen.

6.2.3 Changing the sleep mode setting

- 1 Select [MACHINE SETTING].
→ For details on selecting [MACHINE SETTING], refer to page 6-5.
- 2 Use the ▲/▼ key to select [SLEEP MODE], then press the **OK** key.
- 3 Enter time until the sleep function is enabled using the **Keypad**, then press the **OK** key.

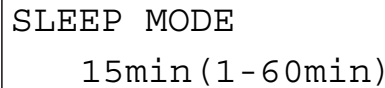

SLEEP MODE
15min (1-60min)

- Configure timer setting between one and 60 minutes.
 - To correct the value, press the **Clear/Stop** key.
- This returns to the Machine Setting screen.

6.2.4 Changing the auto shut time

Specify whether to automatically turn the power off when the specified time elapsed after this machine became inactive. If it is set to be turned off, specify the time required for the power to turn off.

Tips

This machine is not available if the power is turned off by the auto shut time function. Turn on the power when using this machine.

Reference

If [ADMIN. MANAGEMENT] - [DISPLAY AUTO SHUT] is set to [DISABLE], the auto shut time cannot be changed. For details, refer to page 6-19.

- 1 Select [MACHINE SETTING].
→ For details on selecting [MACHINE SETTING], refer to page 6-5.
- 2 Use the ▲/▼ key to select [AUTO SHUT TIME], then press the **OK** key.
- 3 Use the ▲/▼ key to select [OFF] or [ON].
→ If you select [OFF], press the **OK** key.
→ If you select [ON], enter the time required to automatically turn the power off using the **Keypad**, then press the **OK** key.

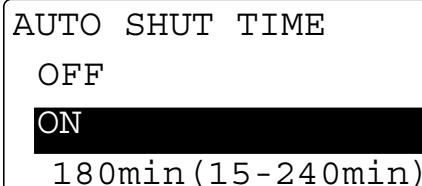

AUTO SHUT TIME
OFF
ON
180min (15-240min)

- The timer can be specified between 15 and 240 minutes.
 - To correct the numeric value, press the **Clear/Stop** key.
- This returns to the machine setting screen.

6.2.5 Changing the image quality when using the ADF

- 1 Select [MACHINE SETTING].
→ For details on selecting [MACHINE SETTING], refer to page 6-5.
- 2 Use the ▲/▼ key to select [DENSITY(ADF)], then press the **OK** key.
- 3 Use the ▲/▼ key to select [MODE1] or [MODE2], then press the **OK** key.

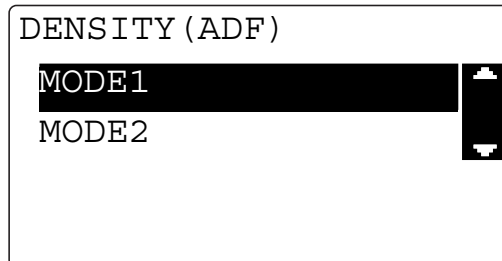

This returns to the Machine Setting screen.

6.2.6 Changing the image quality when using the Original Glass

- 1 Select [MACHINE SETTING].
→ For details on selecting [MACHINE SETTING], refer to page 6-5.
- 2 Use the ▲/▼ key to select [DENSITY(BOOK)], then press the **OK** key.
- 3 Use the ▲/▼ key to select [MODE1] or [MODE2], then press the **OK** key.

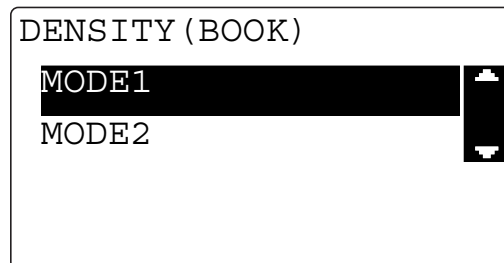

This returns to the Machine Setting screen.

6.2.7 Changing the density

- 1 Select [MACHINE SETTING].
→ For details on selecting [MACHINE SETTING], refer to page 6-5.
- 2 Use the ▲/▼ key to select [PRINT DENSITY], then press the **OK** key.
- 3 Use the ◀/▶ key to select the density level, then press the **OK** key.

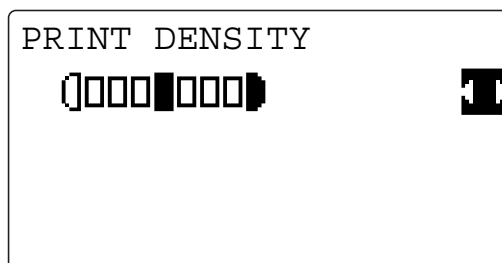

This returns to the Machine Setting screen.

6.2.8 Changing the LCD contrast

- 1 Select [MACHINE SETTING].
→ For details on selecting [MACHINE SETTING], refer to page 6-5.
- 2 Use the ▲/▼ key to select [LCD CONTRAST], then press the **OK** key.
- 3 Use the ◀/▶ key to select the contrast level, then press the **OK** key.

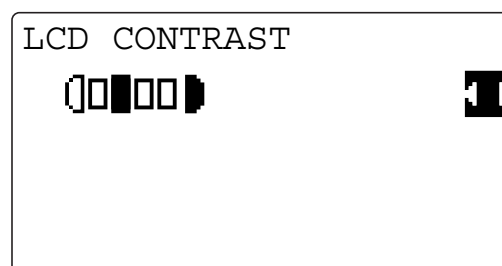

This returns to the Machine Setting screen.

6.2.9 Changing key speed setting

- 1 Select [MACHINE SETTING].
→ For details on selecting [MACHINE SETTING], refer to page 6-5.
- 2 Use the ▲/▼ key to select [KEY SPEED SETTING], then press the **OK** key.
→ To set a value at [INTERVAL], go to Step 5.
- 3 Use the ▲/▼ key to select [TIME TO START], then press the **OK** key.
- 4 Use the ▲/▼ key to select the time period until the function starts, then press the **OK** key.

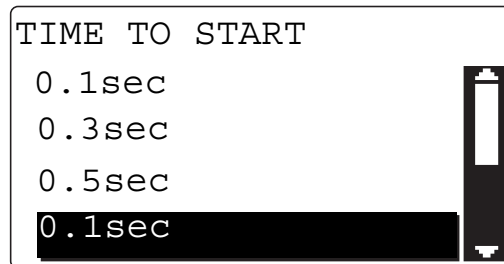

The screen returns to the one for setting key speed.

→ Press the **Back** key to return to the Machine Setting screen.

→ To set a value at [INTERVAL], go to the next step.

- 5 Use the ▲/▼ key to select [INTERVAL], then press the **OK** key.
- 6 Use the ▲/▼ key to select the key speed changing interval, then press the **OK** key.

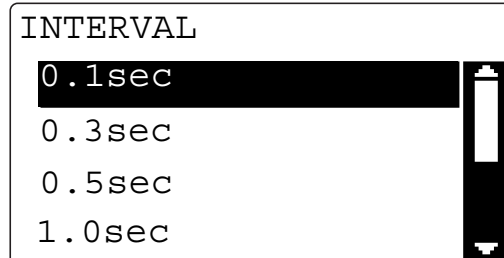

The screen returns to the one for setting key speed.

→ Press the **Back** key to return to the Machine Setting screen.

6.2.10 Changing time interval between continuous key operations

- 1 Select [MACHINE SETTING].
→ For details on selecting [MACHINE SETTING], refer to page 6-5.
- 2 Use the ▲/▼ key to select [DOUBLE-STRIKE KEY], then press the **OK** key.
- 3 Enter the key interval time using the **Keypad**, then press the **OK** key.

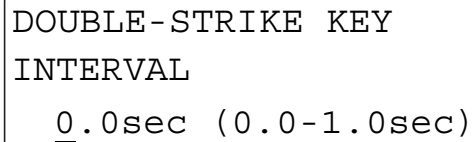

```
DOUBLE-STRIKE KEY  
INTERVAL  
  0.0sec (0.0-1.0sec)
```

- Configure timer setting between 0.0 and 1.0 second.
 - To correct the value, press the **Clear/Stop** key.
- This returns to the Machine Setting screen.

6.2.11 Changing the language to be displayed on the Display

- 1 Select [MACHINE SETTING].
→ For details on selecting [MACHINE SETTING], refer to page 6-5.
- 2 Use the ▲/▼ key to select [LANGUAGE], then press the **OK** key.
- 3 Use the ▲/▼ key to select the language, then press the **OK** key.

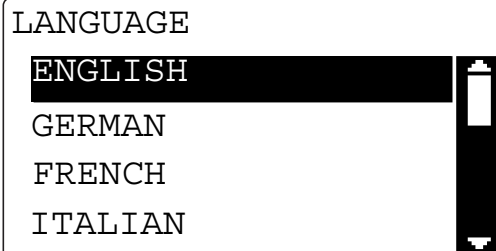

```
LANGUAGE  
ENGLISH  
GERMAN  
FRENCH  
ITALIAN
```

This returns to the Machine Setting screen.

6.3 Tray Settings

Using Tray Settings, you can change the settings for each tray.

<Items for Tray Settings>

Number	Settings	Description
1	[TRAY1]	Specify the size, unit, and type of the paper to be loaded in Tray 1 . Select the paper size from [AUTO], [A6] (A6 CARD), [A6], [B4], [B5], [B5], [B6], [INV], [INV], [EXE], [EXE], [INCH/METRIC], [SIZE INPUT], [MEMORY1], and [MEMORY2]. If you have selected [SIZE INPUT], enter the page size (X: 140 mm to 432 mm, Y: 90 mm to 297 mm). Set the paper unit at [INCH/METRIC]. Select the paper type from [PLAIN], [RECYCLE], [1-SIDE], [SPECIAL], [TRANSPARENCY], [CARD1], [CARD2], [ENVELOPE], [PLAIN 2-SIDE], [CARD1 2-SIDE], [CARD2 2-SIDE], and [RECY. 2-SIDE]. <ul style="list-style-type: none"> The factory default is [AUTO], [PLAIN], and [METRIC].
2	[TRAY2]	Specify the unit of the paper size and paper type. Select in what unit of paper size is used, inches such as Letter or centimeters (metric size) such as A4 and B5. If the setting is not appropriate, the paper size is not automatically detected. Select the paper type from [PLAIN], [RECYCLE], [1-SIDE], and [SPECIAL]. <ul style="list-style-type: none"> The factory default is [PLAIN] and [METRIC].
3	[TRAY3]	Same as TRAY2.
4	[TRAY4]	Same as TRAY2.
5	[TRAY5]	Same as TRAY2.

6.3.1 Selecting tray settings

- 1 Press the **Utility** key.
The Utility screen appears.
- 2 Use the **▲/▼** key to select [PAPER SOURCE SETUP], then press the **OK** key.
The Tray Settings screen appears.

6.3.2 Setting the unit of the paper size

- 1 Select [PAPER SOURCE SETUP].
→ For details on selecting [PAPER SOURCE SETUP], refer to page 6-11.
- 2 Use the ▲/▼ key to select [TRAY1], then press the **OK** key.
- 3 Use the ▲/▼ key to select [PAPER SIZE], then press the **OK** key.
- 4 Use the ▲/▼ key to select [INCH/METRIC], then press the **OK** key.
- 5 Use the ▲/▼ key to select [METRIC] or [INCH], then press the **OK** key.

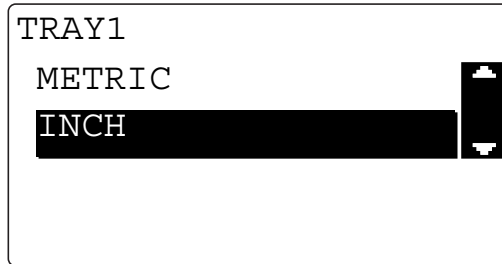

This returns to the Tray Settings screen.

6.3.3 Configuring paper settings for Tray1

- 1 Select [PAPER SOURCE SETUP].
→ For details on selecting [PAPER SOURCE SETUP], refer to page 6-11.
- 2 Use the ▲/▼ key to select [TRAY1], then press the **OK** key.
→ To set the paper type, go to Step 5.
- 3 Use the ▲/▼ key to select [PAPER SIZE], then press the **OK** key.
- 4 Use the ▲/▼ key to select the paper size, then press the **OK** key.
→ For [MEMORY1] or [MEMORY2], you can select the paper size registered in [CUSTOM SIZE MEMORY]. For details on registering the custom size, refer to page 6-14.
→ If you have selected [SIZE INPUT], use the **Keypad** to enter the lengths of X and Y on the next screen, then press the **OK** key.

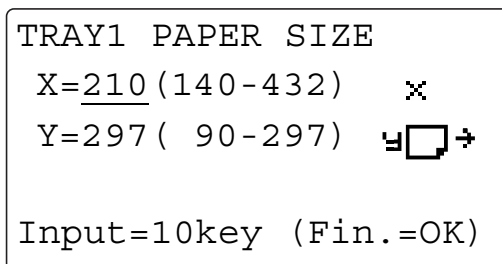

This returns to the Tray Settings screen.

→ To continuously set the paper type, go to Step 5.

- 5 Use the ▲/▼ key to select [PAPER TYPE], then press the **OK** key.

- 6 Use the ▲/▼ key to select the paper type, then press the **OK** key.

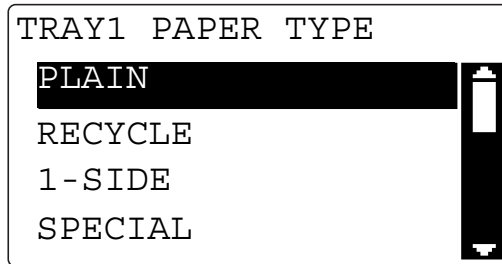

This returns to the Tray Settings screen.

6.3.4 Configuring settings for Tray2 to Tray5

- 1 Select [PAPER SOURCE SETUP].
→ For details on selecting [PAPER SOURCE SETUP], refer to page 6-11.
- 2 Use the ▲/▼ key to select a target tray, then press the **OK** key.
- 3 Use the ▲/▼ key to select [INCH/METRIC], then press the **OK** key.
→ For details on setting the unit of the paper size, refer to page 6-12.
- 4 Use the ▲/▼ key to select [PAPER TYPE], then press the **OK** key.

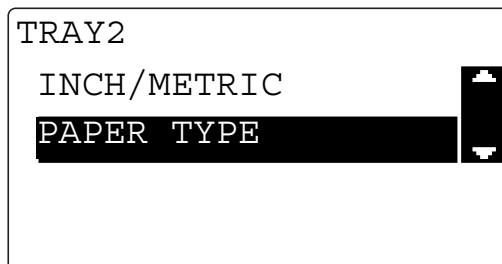

- 5 Use the ▲/▼ key to select the paper type, then press the **OK** key.
This returns to the Tray Settings screen.

6.4 Registering a custom size

For Save Custom Size, you can register up to two frequently used custom sizes. The custom size registered here can be selected when you set the paper size for **Tray1** by selecting [PAPER SOURCE SETUP] - [TRAY1] - [PAPER SIZE].

<Items for Save Custom Size>

Number	Settings	Description
1	[MEMORY1]	Register a frequently used paper size and recall it when you set the paper size. The following size can be registered: Length direction: 140 mm to 432 mm width direction: 90 mm to 297 mm.
2	[MEMORY2]	

6.4.1 Registering a custom size

- 1 Press the **Utility** key.
The Utility screen appears.
- 2 Use the **▲/▼** key to select [CUSTOM SIZE MEMORY], then press the **OK** key.
The screen for registering a custom size appears.
- 3 Use the **▲/▼** key to select the number to be registered, then press the **OK** key.
- 4 Enter a value for the length (X) using the **Keypad**, then press the **OK** key.

```

CUSTOM SIZE MEMORY1
X=140 (140-432)  ✕
Y= 90 ( 90-297)  ↵⏏➡
Input=10key (Fin.=OK)
  
```

- Enter the length (X) and width (Y) of the paper correctly.
- Enter the paper length (X) within the range from 140 mm to 432 mm.
- To correct the entered value, press the **Clear/Stop** key.

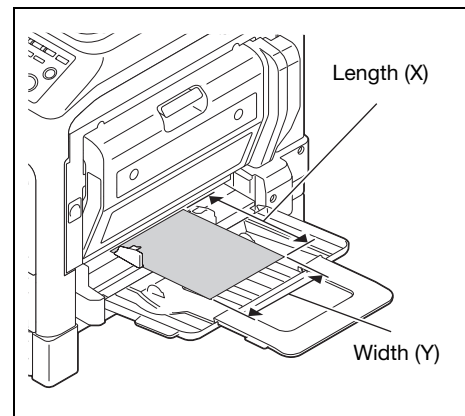

- 5 Enter a value for the width (Y) using the **Keypad**, then press the **OK** key.

ACCEPTED	
X=200 (140-432)	✕
Y=130 (90-297)	↩ □ →

- Enter the paper width (Y) within the range from 90 mm to 297 mm.
 - To correct the entered value, press the **Clear/Stop** key.
- The screen returns to the one for registering a custom size.

6.5 Drum Dry (Dew condensation removal)

If the room temperature changes rapidly (particularly when a heater is used during winter) or the humidity is high, condensation may form on the surface of the photo conductor in this machine, causing a smudgy image to be generated. In this case, use the drum dry (dew condensation removal) function to remove dew condensation. It will take approximately three minutes until the drum dry operation finishes.

- 1** Press the **Utility** key.
The Utility screen appears.
- 2** Use the ▲/▼ key to select [DRUM DEHUMIDIFY], then press the **OK** key.
The Drum Dry screen appears.
- 3** Use the ▲/▼ key to select [DRUM DEHUMIDIFY], then press the **OK** key.

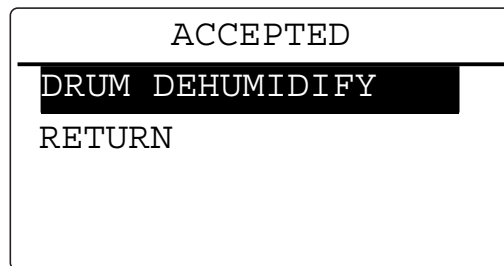

This starts the drum dry operation, and returns to the Drum Dry screen.

6.6 Administrator Settings

Administrator Setting is the mode the administrator of this machine uses. If you select Administrator Setting, you need to enter the administrator number.

<Items for Administrator Settings>

Number	Settings	Description
1	[ADMINISTRATOR NO.]	Change the currently set administrator number to another number.
2	[DISPLAY AUTO SHUT]	Specify whether to enable or disable a change of the auto shut time. To enable a change, select [ENABLE]. To disable a change, select [DISABLE]. <ul style="list-style-type: none"> The factory default is [ENABLE].
3	[SLEEP SHIFT]	When this machine receives a print job from a fax machine or computer in sleep mode, select the timing to switch to sleep mode after the print job has completed. <ul style="list-style-type: none"> [ENABLE]: Switches to sleep mode immediately after a print job has ended. [DISABLE]: Switches to sleep mode based on the time specified in [SLEEP MODE] of [MACHINE SETTING]. The factory default is [DISABLE].
4	[PWR CONS. SLEEP]	Select whether the power-saving during the sleep mode is enabled or not. This item does not appear if the optional FAX Kit FK-510 or Upgrade Kit UK-213 is installed. <ul style="list-style-type: none"> The factory default is [ENABLE].
5	[ACCOUNT TRACK]	Configure settings for performing management by account. Up to 50 accounts can be managed. <ul style="list-style-type: none"> Whether to manage account or not Registering the account number Changing/deleting the account number Displaying/erasing the total counters by account Erasing all total counters by account
6	[REMOTE MONITOR]	This item appears if the optional Fax Kit FK-510 is installed. You can configure remote monitor settings. For details, refer to [User's Guide Fax]. <ul style="list-style-type: none"> The factory default is [OFF].
7	[NETWORK SETTING]	Configure settings required for connecting to the network. For details, refer to the [User's Guide Network Administrator].
8	[WIRELESS SETTING]	This item appears if the optional Upgrade Kit UK-213 is installed. Configure settings for the wireless network. For details, refer to the [User's Guide Network Administrator].
9	[E-MAIL SETTING 1]	Configure settings required for Scan To E-mail. For details, refer to the [User's Guide Network Administrator].
10	[E-MAIL SETTING 2]	This item is required when you use POP BEFORE SMTP authentication. For details, refer to the [User's Guide Network Administrator].
11	[LDAP SETTING]	Configure settings to search for the destination registered in the LDAP server. For details, refer to the [User's Guide Network Administrator].
12	[COMM. SETTING]	This item appears if the optional Fax Kit FK-510 is installed. Configure settings for the FAX function. For details, refer to [User's Guide Fax].
13	[USER SETTING]	Configure the NTP server and time zone settings. For details, refer to [User's Guide Fax].
14	[USB MEMORY SETTING]	Configure settings for USB memories. For details, refer to [User's Guide Scan].
15	[MOBILE SETTING]	Configure settings for mobile devices. For details, refer to [User's Guide Scan].

 **Tips**

The administrator of this machine must not forget the administrator number.

6.6.1 Selecting the administrator setting

- 1 Press the **Utility** key.
The Utility screen appears.
- 2 Use the **▲/▼** key to select [ADMIN. MANAGEMENT], then press the **OK** key.
- 3 Enter the administrator number using the **Keypad**, then press the **OK** key.
→ The factory default is [000000].

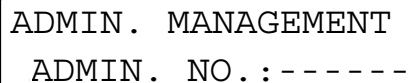

```
ADMIN. MANAGEMENT
ADMIN. NO. : - - - - -
```

→ To correct a value, press the **Clear/Stop** key.
The Administrator Settings screen appears.

6.6.2 Changing the administrator number

- 1 Select [ADMIN. MANAGEMENT].
→ For details on selecting [ADMIN. MANAGEMENT], refer to page 6-18.
- 2 Use the **▲/▼** key to select [ADMINISTRATOR NO.], then press the **OK** key.
- 3 Enter the current administrator number using the **Keypad**, then press the **OK** key.

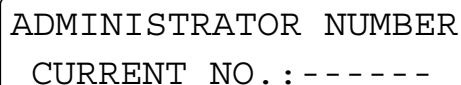

```
ADMINISTRATOR NUMBER
CURRENT NO. : - - - - -
```

→ To correct a value, press the **Clear/Stop** key.

- 4 Enter a new administrator number using the **Keypad**, then press the **OK** key.
- 5 For confirmation, enter the new administrator number, then press the **OK** key.
This returns to the Administrator Settings screen.

6.6.3 Enabling a change of the auto shut time

- 1 Select [ADMIN. MANAGEMENT].
→ For details on selecting [ADMIN. MANAGEMENT], refer to page 6-18.
- 2 Use the ▲/▼ key to select [DISPLAY AUTO SHUT], then press the **OK** key.
- 3 Use the ▲/▼ key to select [ENABLE], then press the **OK** key.
→ If you select [DISABLE], you cannot change the auto shut time.
This returns to the Administrator Settings screen.

6.6.4 Configuring setting so that sleep mode is not used

- 1 Select [ADMIN. MANAGEMENT].
→ For details on selecting [ADMIN. MANAGEMENT], refer to page 6-18.
- 2 Use the ▲/▼ key to select [SLEEP SHIFT], then press the **OK** key.
- 3 Use the ▲/▼ key to select [DISABLE], then press the **OK** key.
This returns to the Administrator Settings screen.

6.6.5 Configuring PWR CONS. SLEEP

- 1 Select [ADMIN. MANAGEMENT].
→ For details on selecting [ADMIN. MANAGEMENT], refer to page 6-18.
- 2 Use the ▲/▼ key to select [PWR CONS. SLEEP], then press the **OK** key.
- 3 Use the ▲/▼ key to select [ENABLE], then press the **OK** key.
This returns to the Administrator Settings screen.

6.6.6 Specifying ACCOUNT TRACK MODE

- 1 Select [ADMIN. MANAGEMENT].
→ For details on selecting [ADMIN. MANAGEMENT], refer to page 6-18.
- 2 Use the ▲/▼ key to select [ACCOUNT TRACK], then press the **OK** key.
- 3 Use the ▲/▼ key to select [ACCOUNT TRACK MODE], then press the **OK** key.
- 4 Use the ▲/▼ key to select [COPY], [PC-PRINT], or [USB DIRECT PRINT], then press the **OK** key.
- 5 Select [ON] or [OFF], then press the **OK** key.
This returns to the Account Track Settings screen.

6.6.7 Registering ID (account)

Register an account number. Up to 50 account numbers can be registered.

- 1 Select [ADMIN. MANAGEMENT].
→ For details on selecting [ADMIN. MANAGEMENT], refer to page 6-18.
- 2 Use the ▲/▼ key to select [ACCOUNT TRACK], then press the **OK** key.
- 3 Use the ▲/▼ key to select [ACCOUNT NO. REG.], then press the **OK** key.
- 4 Enter the account number using the **Keypad**, then press the **OK** key.

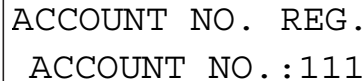

ACCOUNT NO. REG.
ACCOUNT NO. : 111

- Specify the 3-digit ID (account) number.
- To correct the value, press the **Clear/Stop** key.

- 5 Press the **Back** key.
 - If you select [ADD], you can continuously register another ID (account) number.
 - If the number of registered ID (account) numbers exceeds 50, the [UP TO 50 ACCOUNT] message appears.
- This returns to the Account Track Settings screen.

6.6.8 Changing or deleting the ID (account)

- 1 Select [ADMIN. MANAGEMENT].
→ For details on selecting [ADMIN. MANAGEMENT], refer to page 6-18.
- 2 Use the ▲/▼ key to select [ACCOUNT TRACK], then press the **OK** key.
- 3 Use the ▲/▼ key to select [ACCOUNT NO. REG.], then press the **OK** key.
- 4 Enter a target number using the **Keypad**, then press the **OK** key.

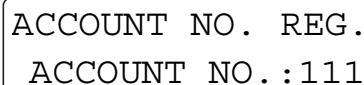

ACCOUNT NO. REG.
ACCOUNT NO. : 111

- Specify the 3-digit ID (account) number.
- To correct the value, press the **Clear/Stop** key.

- 5 Use the ▲/▼ key to select [CHECK/EDIT], then press the **OK** key.

- 6 Use the ▲/▼ key to select the target number.
 - To change the number, press the **OK** key, and go to the next step.
 - To delete the number, press the **Clear/Stop** key, and select [YES].
- 7 Enter a new number using the **Keypad**, then press the **OK** key.

```
ACCOUNT NO. EDIT
ACCOUNT NO. : 112
```

- If the entered ID (account) number has been already registered, [REGISTERED!] is displayed.
 - To continuously change or delete the next number, repeat Steps 6 to 7.
- 8 When all changing or deleting operations have been completed, press the **Back** key.
This returns to the Administrator Settings screen.

6.6.9 Displaying or erasing the total counter by ID (account)

- 1 Select [ADMIN. MANAGEMENT].
 - For details on selecting [ADMIN. MANAGEMENT], refer to page 6-18.
- 2 Use the ▲/▼ key to select [ACCOUNT TRACK], then press the **OK** key.
- 3 Use the ▲/▼ key to select [ACCOUNT TRACK DATA], then press the **OK** key.
- 4 Use the ▲/▼ key to select [DISPLAY], then press the **OK** key.
- 5 Use the ▲/▼ key or the **Keypad** to enter the account number to be displayed, then press the **OK** key.

```
TRACK DATA DISPLAY
ACCOUNT NO. : 111
TOTAL PRINT : 222222
```

The total counters of the selected ID (account) is displayed.

- 6 To erase the displayed counter, press the **Clear/Stop** key.
The total counters of the selected ID (account) is erased.

6.6.10 Erasing all total counters by ID (account)

- 1 Select [ADMIN. MANAGEMENT].
→ For details on selecting [ADMIN. MANAGEMENT], refer to page 6-18.
- 2 Use the ▲/▼ key to select [ACCOUNT TRACK], then press the **OK** key.
- 3 Use the ▲/▼ key to select [ACCOUNT TRACK DATA], then press the **OK** key.
- 4 Use the ▲/▼ key to select [ALL COUNTER CLEAR], then press the **OK** key.
This returns to the screen for the counter by account.

6.7 COPY SETTING 1

The mode when you turn on the power or press the **Reset** key is called the initial mode. COPY SETTING 1 or COPY SETTING 2 enables you to change the initial mode settings for each copy function.

Items of COPY SETTING 1

Number	Settings	Description
1	[PAPER PRIORITY]	Select a tray to be given priority when Auto Zoom is selected from [TRAY1], [TRAY2], [TRAY3], [TRAY4], [TRAY5], and [MULTI BYPASS]. <ul style="list-style-type: none"> The factory default is [TRAY1].
2	[QUALITY PRIORITY]	Select the image quality when you turn on the power or reset the settings from [TEXT], [PHOTO], and [TEXT/PHOTO]. <ul style="list-style-type: none"> The factory default is [TEXT].
3	[DENSITY PRIORITY]	Select the density when you turn on the power or reset the settings from [AUTO] and [MANUAL]. <ul style="list-style-type: none"> The factory default is [AUTO].
4	[DENSITY LEVEL] - [DENSITY LEVEL(A)]	Specify a density level in Auto mode from three levels. <ul style="list-style-type: none"> The factory default is (□□□□).
5	[DENSITY LEVEL] - [DENSITY LEVEL(M)]	Specify a density level in Manual mode from nine levels. <ul style="list-style-type: none"> The factory default is (□□□□□□□□□□).
6	[DUPLEX PRIORITY]	Select an original and proof copy mode when you use the automatic 2-sided printing function from [1-SIDE → 1-SIDE], [1-SIDE → 2-SIDE], [2-SIDE → 1-SIDE], and [2-SIDE → 2-SIDE]. <ul style="list-style-type: none"> The factory default is [1-SIDE → 1-SIDE].
7	[OUTPUT BIND POS.]	Select the page margin position when you use the automatic 2-sided printing function from [LEFT], [RIGHT], and [TOP]. <ul style="list-style-type: none"> The factory default is [LEFT].
8	[ORIG. BINDING POS.]	Select the page margin position of the original when you use the automatic 2-sided printing function from [LEFT], [RIGHT], and [TOP]. <ul style="list-style-type: none"> The factory default is [LEFT].
9	[BINDING POSITION]	Specify the left page (Left Bind) or right page (Right Bind) to be scanned first when a book original is scanned. <ul style="list-style-type: none"> The factory default is [LEFT].
10	[MARGIN SETTING]	Specify the page margin width within the range from 0 mm to 20 mm in steps of 1 mm when giving margin to paper. <ul style="list-style-type: none"> The factory default is 10 mm.
11	[ERASE SETTING]	Specify the erase width on the left, upper, and around the paper when you use the frame/center erase function within the range from 4 mm to 20 mm in steps of 1 mm. <ul style="list-style-type: none"> The factory default is [LEFT]. The erase width is 10 mm.
12	[OUTER ERASE]	Specify the density of the original for outer erase. <ul style="list-style-type: none"> The factory default is (□□□□□□□□).
13	[SMALL ORIGINAL]	Specify whether to [DISABLE] or [ENABLE] copying of a small size original for which the size cannot be automatically detected. <ul style="list-style-type: none"> The factory default is [ENABLE].

6.7.1 Selecting COPY SETTING 1

- 1 Press the **Utility** key.
The Utility screen appears.
- 2 Use the **▲/▼** key to select [COPY SETTING 1], then press the **OK** key.
The COPY SETTING 1 screen appears.

6.7.2 Setting the tray priority

- 1 Select [COPY SETTING 1].
→ For details on selecting [COPY SETTING 1], refer to page 6-24.
- 2 Use the **▲/▼** key to select [PAPER PRIORITY], then press the **OK** key.
- 3 Use the **▲/▼** key to select a target tray, then press the **OK** key.

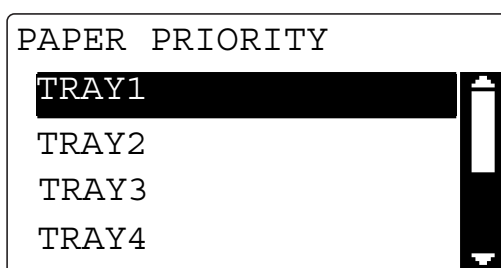

This returns to the COPY SETTING 1 screen.

Tips

If the same size and type of paper as that in the priority tray is loaded into multiple trays and they have run out of paper, a message may appear to notify you to replenish the trays other than the priority tray with paper. If the message appears, replenish paper according to the on-screen instructions.

6.7.3 Specifying the quality priority

- 1 Select [COPY SETTING 1].
→ For details on selecting [COPY SETTING 1], refer to page 6-24.
- 2 Use the **▲/▼** key to select [QUALITY PRIORITY], then press the **OK** key.
- 3 Use the **▲/▼** key to select a target quality, then press the **OK** key.



This returns to the COPY SETTING 1 screen.

6.7.4 Specifying the density priority

- 1 Select [COPY SETTING 1].
→ For details on selecting [COPY SETTING 1], refer to page 6-24.
- 2 Use the ▲/▼ key to select [DENSITY PRIORITY], then press the **OK** key.
- 3 Use the ▲/▼ key to select [AUTO] or [MANUAL], then press the **OK** key.

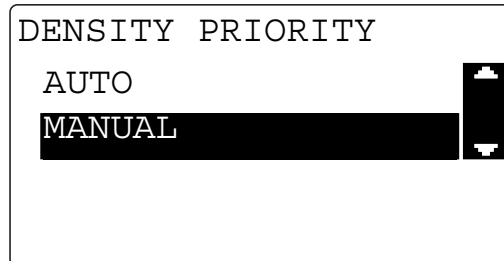

This returns to the COPY SETTING 1 screen.

6.7.5 Specifying the density level priority (Auto)

- 1 Select [COPY SETTING 1].
→ For details on selecting [COPY SETTING 1], refer to page 6-24.
- 2 Use the ▲/▼ key to select [DENSITY LEVEL], then press the **OK** key.
- 3 Use the ▲/▼ key to select [AUTO], then press the **OK** key.
- 4 Use the ◀/▶ key to select the density level, then press the **OK** key.

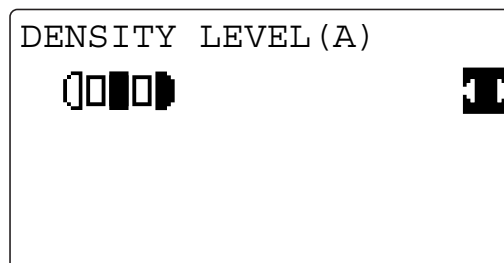

This returns to the COPY SETTING 1 screen.

6.7.6 Specifying the density level priority (Manual)

- 1 Select [COPY SETTING 1].
→ For details on selecting [COPY SETTING 1], refer to page 6-24.
- 2 Use the ▲/▼ key to select [DENSITY LEVEL], then press the **OK** key.
- 3 Use the ▲/▼ key to select [MANUAL], then press the **OK** key.
- 4 Use the ◀▶ key to select the density level, then press the **OK** key.

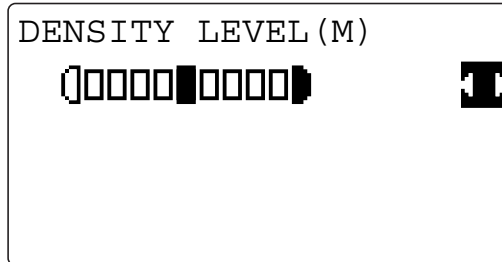

This returns to the COPY SETTING 1 screen.

6.7.7 Setting 2-sided printing

- 1 Select [COPY SETTING 1].
→ For details on selecting [COPY SETTING 1], refer to page 6-24.
- 2 Use the ▲/▼ key to select [DUPLEX PRIORITY], then press the **OK** key.
- 3 Use the ▲/▼ key to select [1-SIDE → 1-SIDE], [1-SIDE → 2-SIDE], [2-SIDE → 1-SIDE], or [2-SIDE → 2-SIDE], then press the **OK** key.

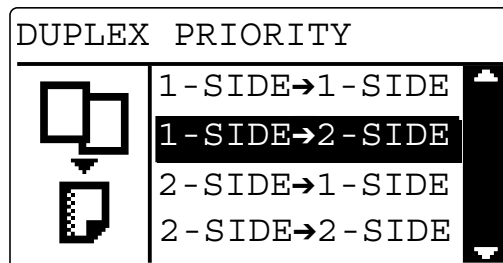

This returns to the COPY SETTING 1 screen.

Tips

If the optional **Reverse Automatic Document Feeder DF-625** is not installed, [2-SIDE → 1-SIDE] and [2-SIDE → 2-SIDE] will not be displayed.

6.7.8 Setting the copy page margin

- 1 Select [COPY SETTING 1].
→ For details on selecting [COPY SETTING 1], refer to page 6-24.
- 2 Use the ▲/▼ key to select [OUTPUT BIND POS.], then press the **OK** key.
- 3 Use the ▲/▼ key to select [LEFT], [RIGHT], or [TOP], then press the **OK** key.

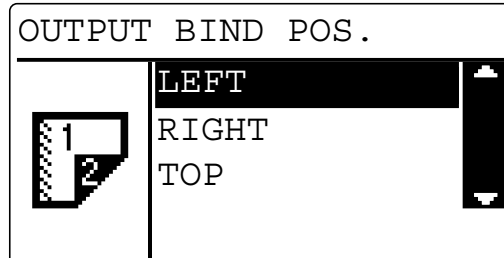

This returns to the COPY SETTING 1 screen.

6.7.9 Setting the original page margin position

- 1 Select [COPY SETTING 1].
→ For details on selecting [COPY SETTING 1], refer to page 6-24.
- 2 Use the ▲/▼ key to select [ORIG. BINDING POS.], then press the **OK** key.
- 3 Use the ▲/▼ key to select [LEFT], [RIGHT], or [TOP], then press the **OK** key.

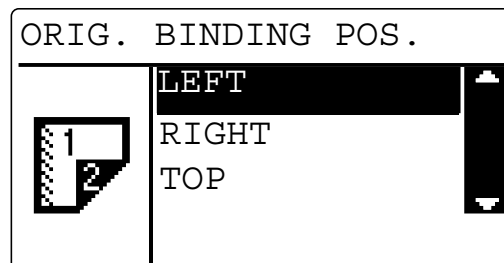

This returns to the COPY SETTING 1 screen.

6.7.10 Setting the book binding position

- 1 Select [COPY SETTING 1].
→ For details on selecting [COPY SETTING 1], refer to page 6-24.
- 2 Use the ▲/▼ key to select [BINDING POSITION], then press the **OK** key.
- 3 Use the ▲/▼ key to select [LEFT] or [RIGHT], then press the **OK** key.

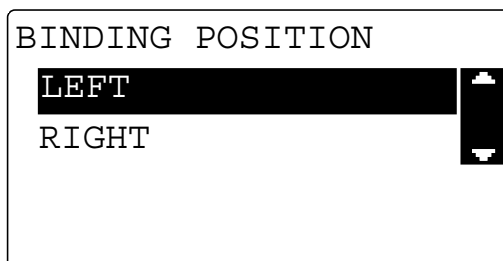

This returns to the COPY SETTING 1 screen.

6.7.11 Adjusting the page margin width

- 1 Select [COPY SETTING 1].
→ For details on selecting [COPY SETTING 1], refer to page 6-24.
- 2 Use the ▲/▼ key to select [MARGIN SETTING], then press the **OK** key.
- 3 Enter the page margin width using the **Keypad**, then press the **OK** key.

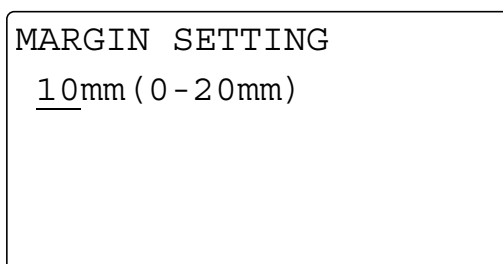

→ You can set the binding margin width within the range from 0 mm to 20 mm.
→ To correct the value, press the **Clear/Stop** key, and enter a new value using the **Keypad**.
This returns to the COPY SETTING 1 screen.

6.7.12 Setting the erase width

- 1 Select [COPY SETTING 1].
→ For details on selecting [COPY SETTING 1], refer to page 6-24.
- 2 Use the ▲/▼ key to select [ERASE SETTING], then press the **OK** key.
- 3 Use the ▲/▼ key to select [LEFT], [UPPER], or [FRAME], then press the **OK** key.
- 4 Enter the erase width using the **Keypad**, then press the **OK** key.

ERASE SETTING (LEFT)
10mm (4 - 20mm)

- You can set the erase width within the range from 4 mm to 20 mm.
- To correct the value, press the **Clear/Stop** key, and enter a new value using the **Keypad**. This returns to the COPY SETTING 1 screen.

6.7.13 Setting the density of the original for OUTER ERASE

- 1 Select [COPY SETTING 1].
→ For details on selecting [COPY SETTING 1], refer to page 6-24.
- 2 Use the ▲/▼ key to select [OUTER ERASE], then press the **OK** key.
- 3 Use the ◀/▶ key to select the density level, then press the **OK** key.

OUTER ERASE
DENSITY LEVEL

□□□□□▶ ▶

This returns to the COPY SETTING 1 screen.

6.7.14 Setting a small size original

- 1 Select [COPY SETTING 1].
→ For details on selecting [COPY SETTING 1], refer to page 6-24.
- 2 Use the ▲/▼ key to select [SMALL ORIGINAL], then press the **OK** key.
- 3 Use the ▲/▼ key to select [DISABLE] or [ENABLE], then press the **OK** key.

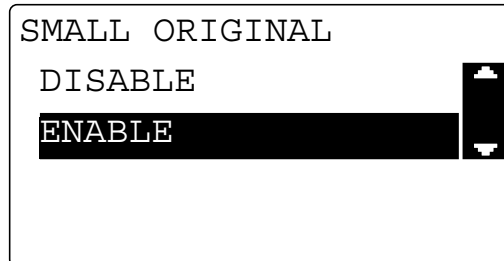

This returns to the COPY SETTING 1 screen.

6.8 COPY SETTING 2

<Items of COPY SETTING 2>

Number	Settings	Settings								
1	[COPY PRIORITY]	Select how to select copy mode when you turn on the power or reset the settings from [AUTO PAPER SELECT], [AUTO ZOOM], and [MANUAL]. <ul style="list-style-type: none"> The factory default is [AUTO PAPER SELECT]. 								
2	[OUTPUT PRIORITY]	Select finishing mode priority when you turn on the power or reset the settings from [NON-SORT], [SORT], and [GROUP]. <ul style="list-style-type: none"> The factory default is [NON-SORT]. 								
3	[CRISSCROSS MODE]	Specify [ON] or [OFF] for alternate output if the conditions for alternately outputting paper are satisfied. <ul style="list-style-type: none"> The factory default is [ON]. 								
4	[4IN1 COPY ORDER]	Select the copy order in 4in1 mode from the two options shown below. When [PATTERN1] is selected, the copies are output combined in the order of upper left, upper right, lower left, and lower right. <div style="text-align: center;"> <table border="1" style="border-collapse: collapse; width: 40px; height: 40px;"> <tr> <td style="text-align: center; width: 20px;">1</td> <td style="text-align: center; width: 20px;">2</td> </tr> <tr> <td style="text-align: center;">3</td> <td style="text-align: center;">4</td> </tr> </table> </div> <p>When [PATTERN2] is selected, the copies are output combined in the order of upper left, lower left, upper right, and lower right.</p> <div style="text-align: center;"> <table border="1" style="border-collapse: collapse; width: 40px; height: 40px;"> <tr> <td style="text-align: center; width: 20px;">1</td> <td style="text-align: center; width: 20px;">3</td> </tr> <tr> <td style="text-align: center;">2</td> <td style="text-align: center;">4</td> </tr> </table> </div> <ul style="list-style-type: none"> The factory default is [PATTERN1]. 	1	2	3	4	1	3	2	4
1	2									
3	4									
1	3									
2	4									
5	[MIXED ORIGINAL]	Specify whether to select the mixed original mode when you turn on the power or reset the settings. This item is available if the optional ADF is installed. <ul style="list-style-type: none"> The factory default is [OFF]. 								
6	[ORIG. DIRECTION]	Select the origin direction from [TOP], [LEFT], [RIGHT], and [BOTTOM]. <ul style="list-style-type: none"> The factory default is [TOP]. 								
7	[BOOK SEPARATION]	Select the print finishing mode in the book separation copy mode from [OFF], [SEPARATION], and [SPREAD]. <ul style="list-style-type: none"> The factory default is [OFF]. 								
8	[STAMP]	Select the stamp printing mode from [OFF], [PAGE NUMBER], [DATE&TIME], and [PAGE+D&T]. <ul style="list-style-type: none"> The factory default is [OFF]. 								
9	[PAGE FORMAT]	Select the [PAGE NUMBER] format to be printed in the stamp printing mode from [P001,P002,] and [1,2,3,]. <ul style="list-style-type: none"> The factory default is [P001,P002,]. 								
10	[DATE&TIME FORMAT]	Select the [DATE&TIME] format to be printed in the stamp printing mode from [MM/DD/YY], [DD/MM/YY], and [YY/MM/DD]. <ul style="list-style-type: none"> The factory default is [MM/DD/YY]. 								

6.8.1 Selecting COPY SETTING 2

- 1 Press the **Utility** key.
The Utility screen appears.
- 2 Use the **▲/▼** key to select [COPY SETTING 2], then press the **OK** key.
The COPY SETTING 2 screen appears.

6.8.2 Setting the copy mode priority

- 1 Select [COPY SETTING 2].
→ For details on selecting [COPY SETTING 2], refer to page 6-32.
- 2 Use the **▲/▼** key to select [COPY PRIORITY], then press the **OK** key.
- 3 Use the **▲/▼** key to select [AUTO PAPER SELECT], [AUTO ZOOM], or [MANUAL], then press the **OK** key.

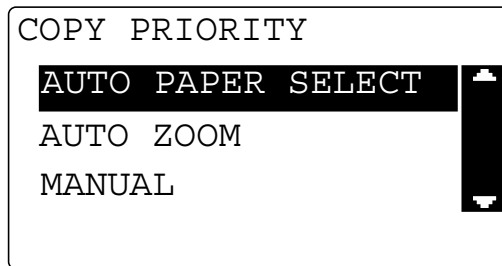

This returns to the COPY SETTING 2 screen.

6.8.3 Specifying the finishing priority

- 1 Select [COPY SETTING 2].
→ For details on selecting [COPY SETTING 2], refer to page 6-32.
- 2 Use the **▲/▼** key to select [OUTPUT PRIORITY], then press the **OK** key.
- 3 Use the **▲/▼** key to select [NON-SORT], [SORT], or [GROUP], then press the **OK** key.

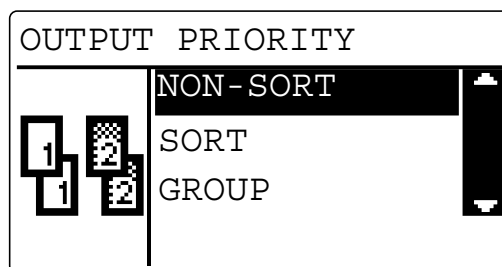

This returns to the COPY SETTING 2 screen.

6.8.4 Specifying the alternate output

- 1 Select [COPY SETTING 2].
→ For details on selecting [COPY SETTING 2], refer to page 6-32.
- 2 Use the ▲/▼ key to select [CRISSCROSS MODE], then press the **OK** key.
- 3 Use the ▲/▼ key to select [OFF] or [ON], then press the **OK** key.

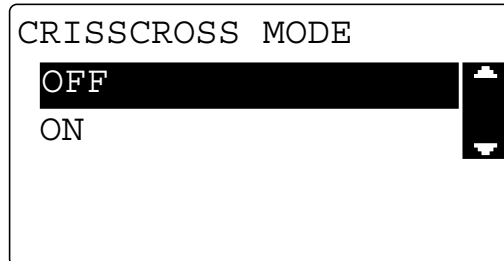

This returns to the COPY SETTING 2 screen.

6.8.5 Setting 4in1 page copy order

- 1 Select [COPY SETTING 2].
→ For details on selecting [COPY SETTING 2], refer to page 6-32.
- 2 Use the ▲/▼ key to select [4IN1 COPY ORDER], then press the **OK** key.
- 3 Use the ▲/▼ key to select [PATTERN1] or [PATTERN2], then press the **OK** key.

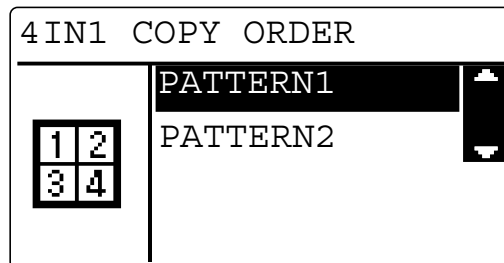

- When [PATTERN1] is selected, the copies are output combined in the order of upper left, upper right, lower left, and lower right.
- When [PATTERN2] is selected, the copies are output combined in the order of upper left, lower left, upper right, and lower right.

This returns to the COPY SETTING 2 screen.

6.8.6 Specifying the mixed original priority

- ✓ This item is available if the optional **ADF** is installed.
- 1 Select [COPY SETTING 2].
 - For details on selecting [COPY SETTING 2], refer to page 6-32.
- 2 Use the ▲/▼ key to select [MIXED ORIGINAL], then press the **OK** key.
- 3 Use the ▲/▼ key to select [OFF] or [ON], then press the **OK** key.

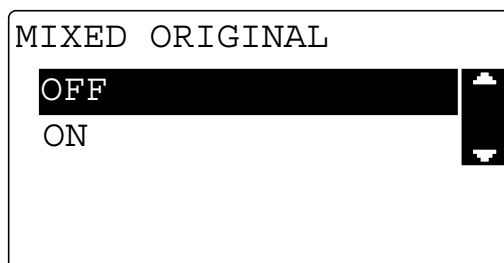

This returns to the COPY SETTING 2 screen.

6.8.7 Configure ORIG. DIRECTION setting

- 1 Select [COPY SETTING 2].
 - For details on selecting [COPY SETTING 2], refer to page 6-32.
- 2 Use the ▲/▼ key to select [ORIG. DIRECTION], then press the **OK** key.
- 3 Use the ▲/▼ key to select [TOP], [LEFT], [RIGHT], or [BOTTOM], then press the **OK** key.

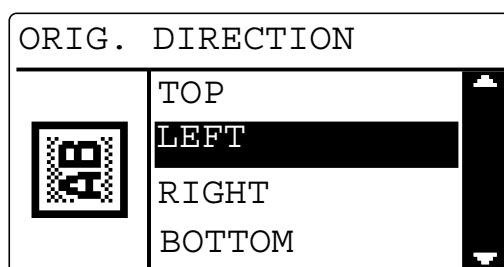

This returns to the COPY SETTING 2 screen.

6.8.8 Configuring BOOK SEPARATION setting

- 1 Select [COPY SETTING 2].
→ For details on selecting [COPY SETTING 2], refer to page 6-32.
- 2 Press the ▲/▼ key to select [BOOK SEPARATION], then press the **OK** key.
- 3 Use the ▲/▼ key to select [OFF], [SEPARATION], or [SPREAD], then press the **OK** key.

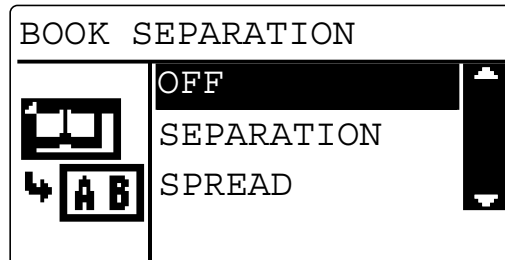

This returns to the COPY SETTING 2 screen.

6.8.9 Setting stamp printing

- 1 Select [COPY SETTING 2].
→ For details on selecting [COPY SETTING 2], refer to page 6-32.
- 2 Use the ▲/▼ key to select [STAMP], then press the **OK** key.
- 3 Use the ▲/▼ key to select [OFF], [PAGE NUMBER], [DATE&TIME], or [PAGE+D&T], then press the **OK** key.

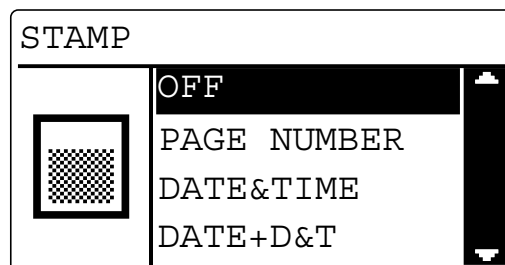

This returns to the COPY SETTING 2 screen.

6.8.10 Setting the page number print format

- 1 Select [COPY SETTING 2].
→ For details on selecting [COPY SETTING 2], refer to page 6-32.
- 2 Use the ▲/▼ key to select [PAGE FORMAT], then press the **OK** key.
- 3 Use the ▲/▼ key to select [P001,P002,] or [1,2,3,], then press the **OK** key.

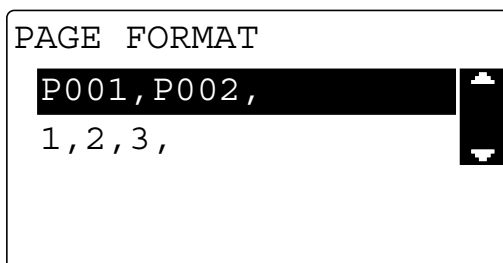

This returns to the COPY SETTING 2 screen.

6.8.11 Setting the date/time print format

- 1 Select [COPY SETTING 2].
→ For details on selecting [COPY SETTING 2], refer to page 6-32.
- 2 Use the ▲/▼ key to select [DATE&TIME FORMAT], then press the **OK** key.
- 3 Use the ▲/▼ key to select [MM/DD/YY], [DD/MM/YY], or [YY/MM/DD], then press the **OK** key.



This returns to the COPY SETTING 2 screen.

6.9 CONFIRM MODE

You can confirm the cumulative number of printed pages and the number of scans from when this machine was installed.

<Items for CONFIRM MODE>

Number	Settings	Description
1	[TOTAL PAGE]	Displays the total number of printed pages and TX/RX (Scan, Fax).
2	[TX/RX RESULT]	Displays the results of TX/RX (Scan, Fax). For details, refer to [User's Guide Fax] / [User's Guide Scan].
3	[PRINT REPORT]	Prints each information registered in this machine as a report.

6.9.1 Items you can confirm using the machine counter

Machine counter	Contents
[TOTAL COUNT]	The total number of printed pages is displayed.
[SIZE COUNT]	Displays the total number of copies/printed pages of the specified paper size as size count. (Your service representative will specify the size of the paper to be counted.)
[TOTAL SCAN]	Displays the total number of scans. (The number of scans for copying is not included.)
[COLOR SCAN]	Displays the total number of color scans. (The number of scans for copying is not included.)
[TX PAGES]	Displays the total number of fax TX and scan TX.
[RX PAGES]	Displays the total number of fax RX.

6.9.2 Viewing the total counter

- 1 Press the **Utility** key.
The utility screen appears.
- 2 Use the **▲/▼** key to select [CONFIRM MODE], then press the **OK** key.
- 3 Use the **▲/▼** key to select [TOTAL PAGE], then press the **OK** key.
- 4 Use the **▲/▼** key to confirm each count value.

TOTAL PAGE

TOTAL COUNT: 000000

SIZE COUNT: 000000

TOTAL SCAN: 000000

COLOR SCAN: 000000



- 5 Press the **OK** key.
The screen returns to the confirm mode screen.

6.9.3 Printing reports

You can print each information registered in this machine as report.

The printable items vary depending on the options being used.

Option	Item
Without FAX Kit FK-510	[TX RESULT REPORT], [ACTIVITY REPORT], [MEMORY DATA LIST], [MEMORY IMAGE PRINT], [ONE-TOUCH LIST], [SPEED DIAL LIST], [KEY SETTING LIST], [MACHINE STATUS], [CONFIGURATION PAGE (PCL)], [PCL FONT LIST]
With FAX Kit FK-510	[TX RESULT REPORT], [RX RESULT REPORT], [ACTIVITY REPORT], [MEMORY DATA LIST], [MEMORY IMAGE PRINT], [ONE-TOUCH LIST], [SPEED DIAL LIST], [KEY SETTING LIST], [RELAY BOX LIST], [MACHINE STATUS], [CONFIGURATION PAGE (PCL)], [PCL FONT LIST]

6.9.4 Printing reports

- 1 Press the **Utility** key.
The utility screen appears.
- 2 Use the **▲/▼** key to select [CONFIRM MODE], then press the **OK** key.
- 3 Use the **▲/▼** key to select [PRINT REPORT], then press the **OK** key.
- 4 Use the **▲/▼** key to select the list to be printed, then press the **OK** key.

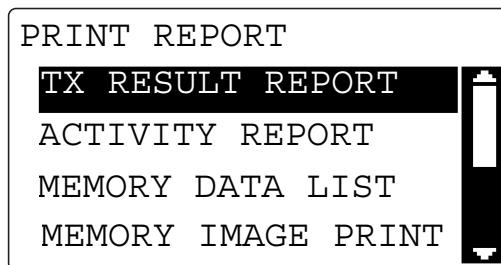

The report is printed.

7

**If you suspect a failure then
do the following**

7 If you suspect a failure then do the following

7.1 If this copy is output

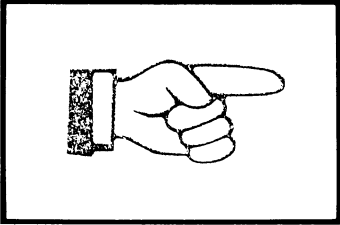
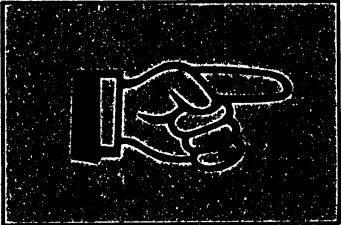
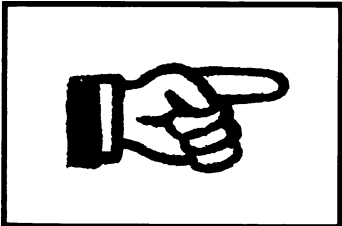
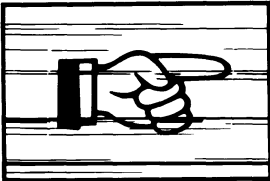
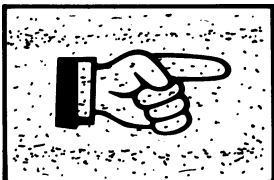
Copy status	Major cause	Correction action
Copy density/color is light.	Is the copy density set to "Light"?	Press the Density key to set the desired copy density. (p. 4-5)
	Is the paper damp?	Replace with new paper. (p. 3-7)
Copy density/color is dark.	Is the copy density set to "Dark"?	Press the Density key to set the desired copy density. (p. 4-5)
	Was the original pressed firmly enough against the Original Glass ?	Position the original so that it is pressed closely against the Original Glass . (p. 3-13)
The ink runs or a copied image is blurred.	Is the paper damp?	Replace with new paper. (p. 3-7)
	Was the original pressed firmly enough against the Original Glass ?	Position the original so that it is pressed closely against the Original Glass . (p. 3-13)
There are streaks on the copy.	Is the Original Glass dirty?	Wipe the Original Glass using a soft, dry cloth. (p. 8-6)
	Is the Original Pad dirty?	Clean the Original Pad using a soft cloth dampened with a mild detergent. (p. 8-7)
	Was the original printed on highly translucent material, such as diazo photosensitive paper or OHP transparencies?	Place a blank sheet of paper on top of the original. (p. 3-14)
There are dark specks or spots throughout the copy.	Is a 2-sided original being copied?	If a thin 2-sided original is being copied, the print on the back side may be reproduced on the front side of the copy. Press the Density key to select a lighter background density. (p. 4-5)
	The end of the service life of Drum Unit .	Contact your service representative.

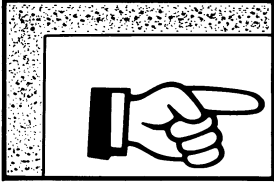
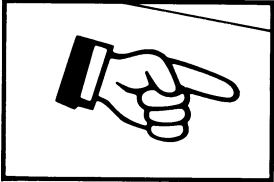
Copy status	Major cause	Correction action
The edge of the copied image is dirty	Is the Original Pad dirty?	Clean the Original Pad using a soft cloth dampened with a mild detergent. (p. 8-7)
	Was the selected paper size larger than the original? (With a Zoom setting of Full Size)	Select a paper size that is the same size as the original. (p. 4-8) Otherwise, select Auto Setting for Zoom to enlarge the copy to the selected paper size. (p. 4-19)
	Is the size or orientation of the original different from that of the paper? (With a Zoom setting of Full Size)	Select a paper size that is the same size as the original. Otherwise, select a paper orientation that is the same as that of the original.
	Was the copy reduced to a size smaller than the paper? (With a reduced zoom specified manually)	Select a copy zoom ratio that adjusts the original size to the selected paper size. (p. 4-19) Otherwise, select Auto Setting for Zoom to reduce the copy to the selected paper size. (p. 4-19)
	The image is copied at an angle.	Is the original positioned correctly?
	Is the original incorrectly positioned in the ADF ?	Open the ADF , and position the original along the Original Scale correctly. (p. 3-12)
	Are the adjustable Lateral Guide correctly positioned against the edges of the paper?	Slide the adjustable Lateral Guide against the edges of the paper.
	Was curled paper loaded into the paper tray?	Flatten the paper before loading it.

7.2 Major messages and troubleshooting

Message	Cause	Correction action
[PAPER JAM Open #th side cover]	A paper jam has occurred in this machine. "#" indicates a tray.	Open the cover at the displayed position, and remove the jammed paper. For details, refer to [Quick Guide].
	Jammed paper is left in this machine. "#" indicates a tray.	Open the cover at the displayed position, and remove the jammed paper again. For details, refer to [Quick Guide].
[Original doc. jam Open doc.feed cover]	Paper jam inside the ADF . Jammed paper is left in the ADF .	Open the cover at the displayed position, and remove the jammed paper. For details, refer to [Quick Guide].
[FRONT COVER OPEN CLOSE FRONT COVER]	The Front Cover of this machine is opened, or not set securely.	Securely close the Front Cover of this machine.
[DOCUMENT COVER OPEN CLOSE DOCUMENT COVER]	An original is loaded into the ADF while the ADF is opened.	Securely close the ADF .
[DOC.FEED COVER OPEN CLOSE DOC.FEED COVER]	The Document Feeder Cover of the ADF is opened.	Securely close the Document Feeder Cover .
[TONER EMPTY SUPPLY TONER]	Toner is depleted. Cannot copy or print data.	Install a new Toner Bottle . For details, refer to [Quick Guide].
[PAPER EMPTY LOAD PAPER(#XXX)]	Paper-out occurs in the selected tray. "#" indicates a tray, and "XXX" indicates the paper size.	Load paper of the displayed size into the displayed tray.
[SET ORIGINAL TO ADF]	When the copy function is started using the ADF (such as mixed original copy), the original is not loaded into the ADF . Or the ADF is opened.	Set the original into the ADF . Securely close the ADF .
[REMOVE ORIGINAL IN ADF]	When the copy function is started using the Original Glass (such as ID COPY), the original is left in the ADF .	Remove the original from the ADF .
[Paper Empty]	(Copy settings being configured) The selected tray has run out of paper.	Load paper of the displayed size into the displayed tray or press the Paper key to select another paper size.
[NO SUITABLE PAPER LOAD PAPER(#XXX)]	<ul style="list-style-type: none"> The paper size of the selected tray was changed when copying operations were being carried out. There is no suitable-size paper when mixed originals are copied in the Auto Paper Select mode. "#" indicates a tray, and "XXX" indicates the paper size. 	Load paper of the displayed size or press the Paper key to select another paper size.
[APS SIZE ERROR(XXX)]	There is no suitable-size paper when the original is copied in the auto paper select mode. "XXX" indicates the paper size.	Load paper of the suitable-size paper or press the Paper key to select another paper size.
[AMS SIZE ERROR]	The zoom ratio based on the combination of the original size and paper size is outside the range from 25% to 400% when the original is copied in the auto zoom select mode.	Load paper of the suitable-size paper or press the Zoom key to select a zoom ratio.

Message	Cause	Correction action
[PAPER SIZE ERROR RESET PAPER(#XXX)]	The paper loaded into the tray does not match the specified size. "#" indicates a tray, and "XXX" indicates the paper size.	When you use the paper feeder unit, remove the loaded paper and load paper according to the procedure in "Loading paper" (p. 3-7). When you are using custom size paper, refer to "Making copies on custom size paper" (p. 4-16). When you use Bypass Tray , remove the loaded paper and load paper according to the procedure in "Loading plain paper in the Bypass Tray " (p. 4-11).
[MEMORY FULL(PRESS ANY KEY)]	Image data scanned by the scanner caused a memory overflow.	Press any key on the Control Panel . Or turn off the Power Switch , and turn it on again. (All scanned data is erased.)
	Image data received from the computer has caused a memory overflow.	Press any key on the Control Panel . Or turn off the Power Switch , and turn it on again. (All scanned data is erased.)
[MAINTENANCE CALL(M1) CALL SERVICE]	Maintenance is due.	Contact your service representative.
[MAINTENANCE CALL(M2) CALL SERVICE]	The time for replacement of Drum Unit .	Contact your service representative.
[MACHINE TROUBLE SERVICE CALL (CXXXX)]	An error has occurred in this machine.	Turn off the Power Switch of this machine, then turn it on again. If this error recurs, contact your service representative.

7.3 The copier does not function.

Copier status	Major cause	Correction action
Nothing is displayed on the Control Panel .	Is only the Start key lit in blue?	The low power (sleep) mode is set. Press any key on the Control Panel to cancel the low power mode. (p. 2-20)
	Was the auto shut-off operation performed?	Turn on the Power Switch .
The Start key does not light in blue.	Have you entered the ID (account) number? <div style="border: 1px solid black; padding: 5px; width: fit-content; margin: 5px auto;"> <p>ACCOUNT NO. : ---</p> <p>Input=10Key</p> </div>	Enter the number according to the procedure in "Entering the ID (account) number". (p. 5-11)
	Is Error on the Control Panel lit?	While viewing the Display to take a corrective action according to the troubleshooting by display.
Even if you press the Start key, you cannot make copies.	The Power Switch has just been turned on, and the copier is in preparation mode.	It will take approximately 15 seconds after you turn on the Power Switch . Please wait.
	Has the power cord been removed from the outlet?	Plug in the power cord.
Power does not appear to have been supplied to this machine.	Has the breaker for the location where this machine is installed been turned OFF?	Turn on the breaker.





















8 Others

8 Others

8.1 Major specifications

8.1.1 bizhub 306/266

Specifications

Type	Scanner, printer, or desktop
Document holder	Fixed mount type
Photo conductor	OPC
Copy system	Laser electrostatic copying
Developing system	HMT system
Fusing system	Heat roller fusing system
Resolution	600 dpi × 600 dpi
Originals	Type: Sheets, books, three-dimensional objects Size: Max. 11 × 17  (A3 ) , Weight: 4-7/16 lb (2 kg)
Copying paper type	Plain paper (17 lb to 23-15/16 lb (64 g/m ² to 90 g/m ²)), Recycled paper (17 lb to 23-15/16 lb (64 g/m ² to 90 g/m ²)) Special paper: Thick 1 (24-3/16 lb to 31-15/16 lb (91 g/m ² to 120 g/m ²), Thick 2 (32-3/16 lb to 41-3/4 lb (121 g/m ² to 157 g/m ²), Transparency, Envelope * Special paper is only available in Tray1 , Bypass Tray .
Copy paper size	< Tray1 > 11 × 17  to 5-1/2 × 8-1/2  /  , A3  to B6  , A6  , 8 × 13  * ¹ Width: 3-9/16 to 11-11/16 inches (90 mm to 297 mm), Length: 5-1/2 to 17 inches (139.7 mm to 431.8 mm) < Bypass Tray > 11 × 17  to 5-1/2 × 8-1/2  /  , A3  to B6  , A6  , 8 × 13  * ¹ , 16K  , 8K  Width: 3-9/16 to 11-11/16 inches (90 mm to 297 mm) Length: 5-1/2 to 17 inches (139.7 mm to 431.8 mm) ¹ Foolscap is provided with the following six types of paper sizes: 8-1/2 × 13-1/2, 220 mm × 330 mm, 8-1/2 × 13, 8-1/4 × 13, 8-1/8 × 13-1/4, and 8 × 13. Any one of these sizes is selectable. For details, contact your service representative.
Paper loading capacity	< Tray1 > Plain paper, Recycled paper: 250 sheets Special paper (Thick paper): 20 sheets, (Transparency): 10 sheets, (Envelope): 10 sheets < Bypass Tray > Plain paper, Recycled paper: 100 sheets Special paper (Thick paper): 20 sheets, (Transparency): 10 sheets, (Envelope): 10 sheets
Warm-up time	13 sec. or less (Room temperature: 73.4°F (23°C))
First copy (8-1/2 × 11  (A4 ) at printing)	5.0 sec. or less

Specifications

Copy speed (per minute)	Copy speed (When printing 8-1/2 × 11" (A4))	1-Sided	bizhub 306 Plain paper: 30 sheets/min. (Thick paper: 10 sheets/min.) bizhub 266 Plain paper: 26 sheets/min. (Thick paper: 9 sheets/min.)
		2-Sided	bizhub 306 Plain paper: 22 sheets/min. bizhub 266 Plain paper: 21 sheets/min.
Copy magnification	Full Size: 100% Enlarge <Inch area>: 121%, 129%, 200%, 400% <Metric area>: 115%, 141%, 200%, 400% Reduce <Inch area>: 78%, 64%, 50%, 25% <Metric area>: 81%, 70%, 50%, 25% Zoom: 25% to 400% (in steps of 1%)		
Number of continuous copies	1 to 999 sheets		
Auto duplex	Paper type	Plain paper (17 lb to 23-15/16 lb (64 g/m ² to 90 g/m ²))	
	Paper size	11 × 17" to 5-1/2 × 8-1/2"/, A3 to A5"/, 8 × 13" ^{*1} , 16K"/, 8K" Width: 5-1/2 to 11-11/16 inches (139.7 mm to 297 mm), Length: 5-1/2 to 17 inches (139.7 mm to 431.8 mm) ^{*1} Foolscap is provided with the following six types of paper sizes: 8-1/2 × 13-1/2, 220 mm × 330 mm, 8-1/2 × 13, 8-1/4 × 13, 8-1/8 × 13-1/4, and 8 × 13. Any one of these sizes is selectable. For details, contact your service representative.	
Density adjustment	Auto and manual adjustment of nine levels		
Image missing	Leading edge: 3/16 inches (4 mm), trailing edge: 3/16 inches (4 mm), back side: 3/16 inches (4 mm), front side: 3/16 inches (4 mm)		
Power supply	AC 220 V to 240 V, 6.5 A, 50/60 Hz		
Max. power consumption	1550 W or less		
Size	Width: 24-11/16 inches (627 mm) × Depth: 22-7/16 inches (570 mm) × Height: 18-1/16 inches (458 mm) (to the surface of the Original Glass)		
Weight	67-7/8 lb (30.8 kg)		
Standard memory	Copy side: 512 MB		

8.1.2 Reverse Automatic Document Feeder DF-625

Specifications

Original feed mode	1-sided original, 2-sided original, mixed original
Original type	1-Sided: Plain paper (9-5/16 lb to 34-1/16 lb (35 g/m ² to 128 g/m ²)) 2-Sided/Mixed: (13-5/16 lb to 34-1/16 lb (50 g/m ² to 128 g/m ²))
Original Size	1-Sided/2-Sided: 11 × 17□ to 5-1/2 × 8-1/2□/□, A3□ to A5□/□ For details on handling mixed originals, refer to page 3-16.
Original loading capacity	Max. 70 sheets (21-1/4 lb (80 g/m ²))
Max. power consumption	14.4 W or less
Size	Width: 21-1/2 inches (546 mm) × Depth: 19-1/8 inches (486 mm) × Height: 3-1/8 inches (80 mm)
Weight	11-11/16 lb (5.3 kg)

8.1.3 Paper Feeder Unit PF-509

Specifications

Paper type	Plain paper, Recycled paper (15-15/16 lb to 23-15/16 lb (64 g/m ² to 90 g/m ²))
Paper size	11 × 17□ to 5-1/2 × 8-1/2 □, A3□ to B5□
Number of loadable sheets	250 sheets
Max. power consumption	9 W or less
Size	Width: 22-7/16 inches (570 mm) × Depth: 20-7/8 inches (530 mm) × Height: 4-1/4 inches (108 mm)
Weight	11-7/8 lb (5.4 kg)

8.2 Daily maintenance

This section describes how to clean each part.

Important

- Be sure to turn off the **Power Switch** of this machine before starting cleaning.

8.2.1 Housing

Wipe the surface of the housing using a soft cloth moistened with a mild household detergent.

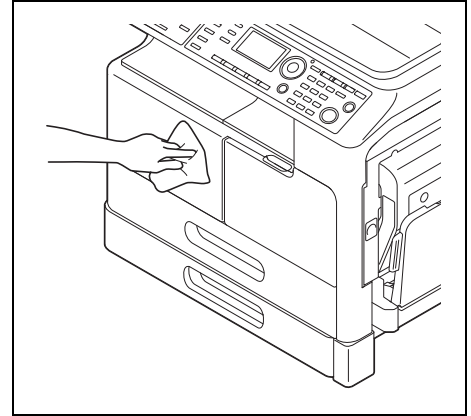

8.2.2 Original Glass

Wipe the surface of the **Original Glass** using a soft cloth.

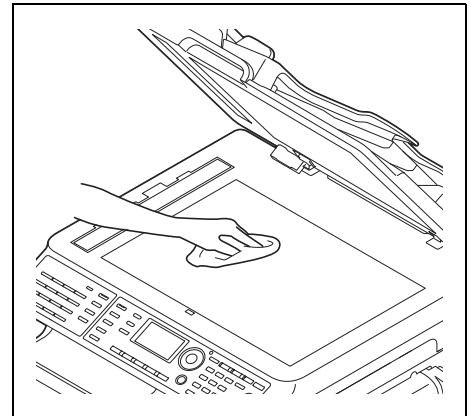

8.2.3 Slit Scan Glass

Wipe the surface of the **Slit Scan Glass** using a soft cloth.

- Wipe off stains from the back side to the front side along the guide.

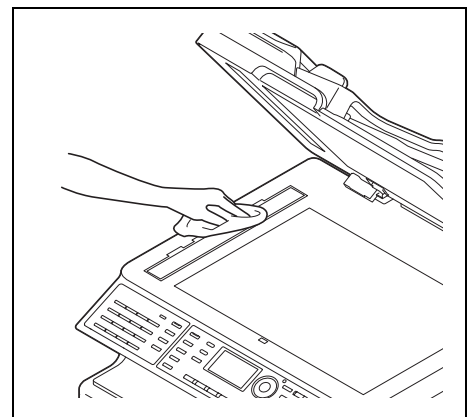

8.2.4 Original Pad

Wipe the surface of the **Original Pad** using a soft cloth moistened with alcohol.

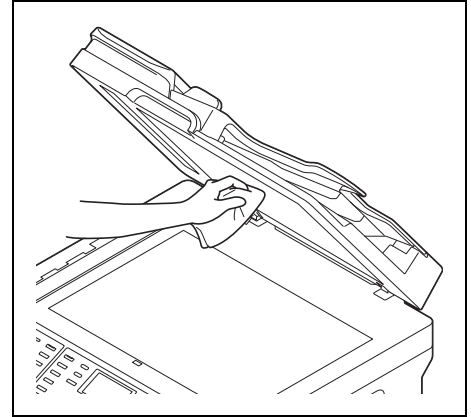

8.2.5 Control Panel

Wipe the surface of the **Control Panel** using a soft cloth.

Important

- Do not use a mild household detergent or glass cleaner, otherwise the keys may be damaged.

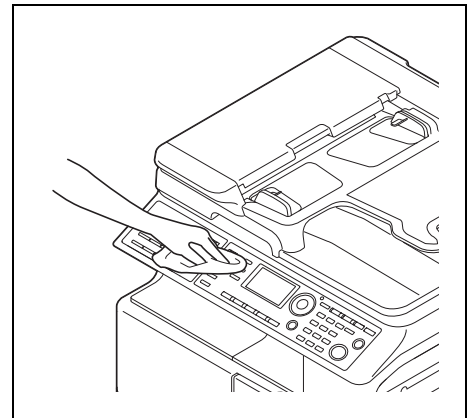



9 **Index**

9 Index

9.1 Index by item

Numerics

2in1 copy 5-8

4in1 copy 5-8

A

Access 2-10

AddressBook 2-10

Administrator Settings 6-17

Alternate Group 5-3

Alternate Sort 5-3

Auto panel reset 2-19

Auto Panel Reset Setting 6-5

Auto paper setting 3-16

Auto RX Indicator 2-13

Auto shut time 2-20

Auto tray change 4-8

Auto zoom 4-19

Automatic Duplex Unit 2-8

B

Binding margin setting 5-18

Book original 3-15

Book separation copy 5-12

Bypass copy 4-10

Bypass Tray 2-5, 4-10

Bypass Tray Extension 2-5, 4-10

C

Changing ID (account number) 6-20

Changing the administrator number 6-18

Changing the auto shut time 6-6

Clear/Stop 2-10

Combine Original 2-10

Control Panel 2-10

Copy 2-10, 4-3

Copy density setting 4-5, 4-22

Copy mode screen 2-14

COPY SETTING 1 6-23

COPY SETTING 2 6-31

Copy setting registration 5-20

Copying area 3-5

Custom size paper 3-4, 4-16

D

Date/time printing 5-19

Deleting ID (account number) 6-20

Density 2-10

Display 2-10, 2-14

Display auto shut 2-22, 6-6, 6-19

Displaying total counter 6-21

Double-Strike Key Setting 6-10

Drum Dry 6-16

E

Enabling a change of the auto shut time 6-19

Enter custom size paper 4-16

Envelope 3-3, 4-12, 4-18

Erase 5-14

Erase print job 4-7

Erasing total counter 6-21

Error Indicator 2-10

Extended Operation Panel MK-750 2-13

Exterior of the main unit 2-5

F

Fax 2-10

Finishing 2-10, 5-3

Finishing setting 5-5

Fixed zoom 4-19

Fixed zoom setting 4-20

Frame/Center erase 5-13

Full size 4-19

Function 2-10

G

Grouping 5-3

I

Icon 2-14

ID (Account) number 5-11

ID Copy 2-10, 5-10

Image quality setting 4-4, 6-7

Initial mode 2-19

Interior of the main unit 2-7

K

Key speed setting 6-9

Keypad 2-10

L

Language setting 6-10

Lateral Guide 3-12

LCD contrast 6-8

Loadable number of sheets 3-3

Loading paper 3-7, 4-11

M

Machine counter 6-37
Machine Setting 6-4
Main Power Switch 2-19
Main unit configuration 2-3
Manual zoom 4-20
Memory TX 2-13
Message display 2-14
Messages 7-5
Mixed original 3-16
Mode Memory 2-10

N

Negative-positive reversal 5-17
Next Copy Job 2-20
Non-sort 5-3
Number of copies 4-3

O

OHP 3-14, 4-12, 4-15
On Hook 2-13
One-Touch Dial Key 2-13
Option configuration 2-3
Original direction 4-6
Original Glass 3-13
Original Scale 3-13
Original set 3-10
Original size 3-10
Original type 3-10
OUTER ERASE 6-29
Outer Eraser 5-15

P

Page margin 5-18
Page number printing 5-19
Paper 2-10
Paper Feeder Unit 2-9
Paper selection 4-8
Paper size 3-4
Paper take-up roller 3-7
Paper that cannot be used for copying 3-4
Paper tray 4-8
Paper type 3-3, 4-15
Photo mode 4-22
Plain paper 3-3
Power Save 2-10
Power saving 2-21
Precautions on originals 3-11
Print density setting 6-8
Printer 2-10
Printer Indicator 2-10
Printing area 3-5
PWR CONS. SLEEP 6-19

Q

Quality 2-10

R

Recycled paper 3-3
Redial/Pause 2-13
Reduce/enlarge setting 4-4
Registering ID (account) 6-20
Report printing 6-38
Reset 2-10
Restart copy job 4-7
Reverse Automatic Document Feeder 2-8

S

Save Custom Size 6-14
Scan 2-10
Setting 2-sided printing 6-26
Setting 4in1 page copy order 6-33
Setting a small size original 6-30
Setting original direction 6-34
Setting sleep mode 2-21, 6-19
Setting the book binding position 6-28
Setting the book separation copy 6-35
Setting the copy mode priority 6-32
Setting the copy page margin 6-27
Setting the date/time print format 6-36
Setting the erase width 6-29
Setting the original page margin position 6-27
Setting the page margin width 6-28
Setting the page number printing 6-36
Setting the stamp printing 6-35
Setting the tray priority 6-24
Simplex/Duplex 2-10, 5-6
Sleep mode 2-20
Sleep Mode Settings 6-6
Sorting 5-3
Specifying the administrator mode 6-18
Specifying the alternate output 6-33
Specifying the density level priority (Auto) 6-25
Specifying the density level priority (Manual) 6-26
Specifying the density priority 6-25
Specifying the finishing priority 6-32
Specifying the mixed original priority 6-34
Specifying the quality priority 6-24
Speed Dial 2-13
Standard paper 3-4
Standard size printing 4-4
Start 2-10, 4-3
Stop 4-3
Stop copy job 4-7
Storing paper 3-6
Switching Plate 2-13

T

Text mode 4-22
Text/Photo mode 4-22
Thick 1 3-3
Thick 2 3-3
Total counter 6-37

Tracing paper 3-14
Transparency 3-3, 3-14
Tray change 4-8
Tray Settings 6-11
Tray1 3-7, 6-12
Tray2 3-8, 6-13
Tray3 3-8, 6-13
Tray4 3-8, 6-13
Tray5 3-8, 6-13
Troubleshooting 7-5, 7-7
Turning ON/OFF the power 2-19

U

Unit of paper size 6-12
Utility 2-10, 6-3

X

X/Y variable zoom ratio 4-19, 4-21

Z

Zoom 2-10, 4-19

9.2 Index by button

Numerics

1-SIDE 4-14
 1-SIDE -> 1-SIDE 5-6
 1-SIDE -> 2-SIDE 5-6
 2in1 5-9
 2-SIDE -> 1-SIDE 5-6
 2-SIDE -> 2-SIDE 5-6
 4in1 5-9
 4IN1 COPY ORDER 6-31, 6-33

A

ACCOUNT NO. REG. 6-20
 ACCOUNT TRACK 6-17
 ACCOUNT TRACK DATA 6-21
 ACCOUNT TRACK MODE 6-19
 ADMIN. MANAGEMENT 6-3, 6-18
 ADMINISTRATOR NO. 6-17, 6-18
 ALL COUNTER CLEAR 6-22
 AUTO 4-19
 AUTO PANEL RESET 6-4, 6-5
 AUTO SHUT TIME 2-22, 6-4

B

BINDING POSITION 6-23, 6-28
 BOOK SEP. 5-12
 BOOK SEPARATION 6-31, 6-35
 Buzzer Volume 6-4

C

CARD1 4-14
 CARD1 2-SIDE 4-14
 CARD2 4-14
 CARD2 2-SIDE 4-14
 COMM. SETITNG 6-17
 CONFIRM MODE 6-3
 COPY PRIORITY 6-31, 6-32
 COPY SETTING 1 6-3, 6-24
 COPY SETTING 2 6-3, 6-32
 CRISSCROSS MODE 6-31, 6-33
 CUSTOM SIZE MEMORY 6-3, 6-14

D

DATE&TIME FORMAT 6-31, 6-36
 DENSITY LEVEL 6-25, 6-26
 DENSITY LEVEL(A) 6-23
 DENSITY LEVEL(M) 6-23
 DENSITY PRIORITY 6-23, 6-25
 DENSITY(ADF) 6-4, 6-7
 DENSITY(BOOK) 6-4, 6-7
 DIAL REGISTRATION 6-3
 DISPLAY AUTO SHUT 6-6, 6-17, 6-19
 DOUBLE-STRIKE KEY 6-4, 6-10
 DRUM DEHUMIDIFY 6-3, 6-16
 DUPLEX PRIORITY 6-23, 6-26

E

E-MAIL SETTING 1 6-17
 E-MAIL SETTING 2 6-17
 ENVELOPE 4-14, 4-18
 ERASE 5-14
 ERASE SETTING 6-23, 6-29

F

FIXED 4-20

G

GROUP 5-5

I

INCH/METRIC 6-12
 Initial mode 6-4

K

KEY SPEED SETTING 6-4, 6-9

L

LANGUAGE 6-4, 6-10
 LCD CONTRAST 6-4, 6-8
 LDAP SETTING 6-17

M

MACHINE SETTING 6-3, 6-5
 MANUAL 4-20
 MARGIN SETTING 6-23, 6-28
 MIXED ORIGINAL 6-31, 6-34
 MOBILE SETTING 6-17

N

NEG. POS. 5-17
 NETWORK SETTING 6-17
 NON-SORT 5-5

O

ORIG. BINDING POS. 6-23, 6-27
 ORIG. DIRECT 4-6
 ORIG. DIRECTION 6-31
 OUTER ERASE 5-16, 6-23, 6-29
 OUTPUT BIND POS. 6-23, 6-27
 OUTPUT PRIORITY 6-31, 6-32

P

PAGE FORMAT 6-31, 6-36
 PAGE MARGIN 5-18
 PAGE NUMBER 5-19
 PAPER PRIORITY 6-23, 6-24
 PAPER SIZE 6-12
 PAPER SOURCE SETUP 6-3
 PLAIN 4-14
 PLAIN 2-SIDE 4-14
 PRINT DENSITY 6-4, 6-8
 PRINT REPORT 6-37, 6-38
 PWR CONS. SLEEP 6-17, 6-19

Q

QUALITY PRIORITY 6-23, 6-24

R

RECALL 5-21

RECY. 2-SIDE 4-14

RECYCLE 4-14

REGISTER 5-20

REMOTE MONITOR 6-17

S

SCAN SETTING 6-3

SCAN THRESHOLD 6-4

SIZE 4-13

SIZE INPUT 4-16

SLEEP MODE 2-21, 6-4, 6-6

SLEEP SHIFT 6-17, 6-19

SMALL ORIGINAL 6-23, 6-30

SORT 5-5

SPECIAL 4-14

STAMP 6-31, 6-35

T

TOTAL PAGE 6-37

TRANSPARENCY 4-14, 4-16

TRAY1 6-11, 6-12

TRAY2 6-11

TRAY3 6-11

TRAY4 6-11

TRAY5 6-11

TYPE 4-13

U

USB MEMORY SETTING 6-17

USER SETTING 6-17

W

WIRELESS SETTING 6-17

X

X/Y ZOOM 4-21

