

Dell PowerEdge T20 Owner's Manual

Regulatory Model: D13M
Regulatory Type: D13M001



Notes, Cautions, and Warnings



NOTE: A NOTE indicates important information that helps you make better use of your computer.



CAUTION: A CAUTION indicates either potential damage to hardware or loss of data and tells you how to avoid the problem.



WARNING: A WARNING indicates a potential for property damage, personal injury, or death.

© 2013 Dell Inc. All Rights Reserved.

Trademarks used in this text: Dell™, the Dell logo, Dell Boomi™, Dell Precision™, OptiPlex™, Latitude™, PowerEdge™, PowerVault™, PowerConnect™, OpenManage™, EqualLogic™, Compellent™, KACE™, FlexAddress™, Force10™, Venue™ and Vostro™ are trademarks of Dell Inc. Intel®, Pentium®, Xeon®, Core® and Celeron® are registered trademarks of Intel Corporation in the U.S. and other countries. AMD® is a registered trademark and AMD Opteron™, AMD Phenom™ and AMD Sempron™ are trademarks of Advanced Micro Devices, Inc. Microsoft®, Windows®, Windows Server®, Internet Explorer®, MS-DOS®, Windows Vista® and Active Directory® are either trademarks or registered trademarks of Microsoft Corporation in the United States and/or other countries. Red Hat® and Red Hat® Enterprise Linux® are registered trademarks of Red Hat, Inc. in the United States and/or other countries. Novell® and SUSE® are registered trademarks of Novell Inc. in the United States and other countries. Oracle® is a registered trademark of Oracle Corporation and/or its affiliates. Citrix®, Xen®, XenServer® and XenMotion® are either registered trademarks or trademarks of Citrix Systems, Inc. in the United States and/or other countries. VMware®, vMotion®, vCenter®, vCenter SRM™ and vSphere® are registered trademarks or trademarks of VMware, Inc. in the United States or other countries. IBM® is a registered trademark of International Business Machines Corporation.

2013 - 12

Rev. A01

Contents

1 About Your System.....	7
Front-Panel Features And Indicators.....	7
Back-Panel Features And Indicators.....	8
NIC Indicator Codes.....	9
Power Indicator Codes For Power Supply.....	10
Complete The Operating System Setup.....	10
Supported Operating Systems.....	10
Other Information You May Need.....	11
2 Using The System Setup And Boot Manager.....	13
Choosing The System Boot Mode.....	13
Entering System Setup.....	14
Using The System Setup Navigation Keys.....	14
Updating The BIOS	14
Responding To Error Messages.....	15
System Setup Options.....	15
Boot Manager Screen.....	22
Using The Boot Manager Navigation Keys.....	23
System And Admin Password Features.....	23
Assigning A System Password And Admin Password.....	24
Deleting Or Changing An Existing System And Admin Password.....	24
Intel Active Management Technology	24
3 Installing System Components.....	27
Recommended Tools.....	27
Opening And Closing The System.....	27
Opening The System.....	27
Closing The System.....	28
Bezel.....	28
Removing The Bezel.....	28
Installing The Bezel.....	29
Chassis-Intrusion Switch.....	29
Removing The Chassis-Intrusion Switch.....	30
Installing The Chassis-Intrusion Switch.....	30
Inside The System.....	31
Thermal Sensor.....	32
Removing The Thermal Sensor.....	32
Installing The Thermal Sensor.....	32

Power Switch.....	33
Removing The Power Switch.....	33
Installing The Power Switch.....	34
Input/Output Panel.....	34
Removing The Input/Output Panel.....	34
Installing The Input/Output Panel.....	35
Hard Drives.....	36
Removing The Hard-Drive Cage.....	36
Installing The Hard-Drive Cage.....	37
Removing A 3.5 Inch Hard Drive From The Hard-Drive Cage.....	37
Installing A 3.5 Inch Hard Drive In The Hard-Drive Cage.....	38
Removing A 2.5 Inch Hard Drive From The Hard-Drive Cage.....	39
Installing A 2.5 Inch Hard Drive In The Hard-Drive Cage.....	40
Removing A 3.5 Inch Hard Drive From The Hard-Drive Bay.....	41
Installing A 3.5 Inch Hard Drive In The Hard-Drive Bay.....	42
Removing A Hard Drive From A Hard-Drive Carrier.....	43
Installing A Hard Drive Into A Hard-Drive Carrier.....	43
Optical Drive.....	43
Installing The Optical Drive.....	43
Removing The Optical Drive.....	46
System Memory.....	46
General Memory Module Installation Guidelines.....	47
Sample Memory Configurations.....	48
Removing Memory Modules.....	48
Installing Memory Modules.....	49
System Fan.....	50
Removing The System Fan.....	50
Installing The System Fan.....	51
Expansion Cards.....	52
Expansion Card Installation Guidelines.....	52
Removing An Expansion Card.....	52
Installing An Expansion Card.....	53
Processors.....	54
Removing The Processor.....	54
Installing The Processor.....	56
Power Supply	57
Removing The Power Supply Unit.....	57
Installing The Power Supply Unit.....	58
System Battery.....	59
Replacing The System Battery.....	59
System Board.....	60
Removing The System Board.....	60

Installing The System Board.....	61
Entering The Service Tag After Replacing The System Board.....	62
4 Troubleshooting Your System.....	63
Safety First—For You And Your System.....	63
Power LED Diagnostics.....	63
Memory Beep Code.....	64
Troubleshooting System Startup Failure.....	64
Troubleshooting External Connections.....	64
Troubleshooting The Video Subsystem.....	64
Troubleshooting A USB Device.....	64
Troubleshooting A Serial I/O Device.....	65
Troubleshooting A NIC.....	65
Troubleshooting A Wet System.....	66
Troubleshooting A Damaged System.....	66
Troubleshooting The System Battery.....	67
Troubleshooting A Non-Redundant Power Supply.....	67
Troubleshooting Cooling Problems.....	67
Troubleshooting The System Fan.....	68
Troubleshooting System Memory.....	68
Troubleshooting An Optical Drive.....	69
Troubleshooting A Hard Drive.....	69
Troubleshooting Expansion Cards.....	70
Troubleshooting The Processor.....	70
5 Using System Diagnostics.....	71
Enhanced Pre-Boot System Assessment Diagnostics.....	71
System Diagnostic Controls.....	71
6 Jumpers And Connectors.....	73
System Board Jumper Settings.....	73
System Board Connectors.....	73
Disabling A Forgotten Password.....	74
7 Technical Specifications.....	77
Environmental Specifications.....	78
8 System Messages.....	81
Error Messages.....	81
Warning Messages.....	84
Alert Messages.....	84

9 Getting Help.....	85
Contacting Dell.....	85
Locating Your System Service Tag.....	85
Documentation Feedback.....	85

About Your System

Front-Panel Features And Indicators

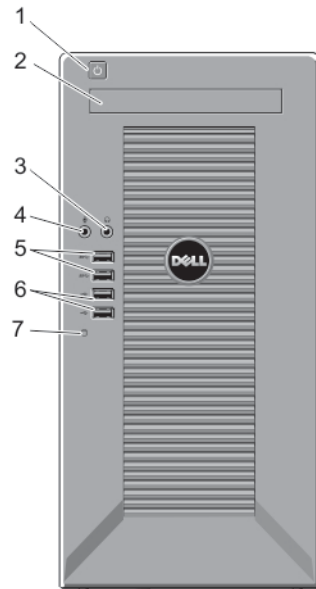







Figure 1. Front-Panel Features and Indicators

Item	Indicator, Button, or Connector	Icon	Description
1	Power-on indicator, power button		<p>The power-on indicator lights when the system power is on. The power button controls the power supply output to the system.</p> <p>NOTE: On ACPI-compliant operating systems, turning off the system using the power button causes the system to perform a graceful shutdown before power to the system is turned off.</p>
2	Optical drive (optional)		One optional slim SATA DVD-ROM drive or DVD+/-RW drive.
3	Headphone connector		Allows you to connect a headphone to the system.
4	Microphone connector		Allows you to connect a microphone to the system.

Item	Indicator, Button, or Connector	Icon	Description
5	USB connectors (2)		Allow you to connect USB devices to the system. The ports are USB 3.0 compliant.
6	USB connectors (2)		Allow you to connect USB devices to the system. The ports are USB 2.0 compliant.
7	Hard drive indicator		Indicates the hard drive activity.

Back-Panel Features And Indicators

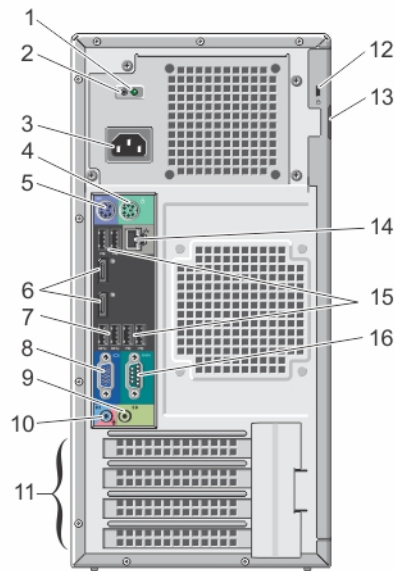













Figure 2. Back-Panel Features and Indicators

Item	Indicator, Button, or Connector	Icon	Description
1	AC power supply status indicator		Indicates power supply activity.
2	Self-diagnostic button		Indicates the health status of the non-redundant power supply.
3	Power supply		One 290 W non-redundant AC power supply.
4	PS/2 mouse connector		Allows you to connect a PS/2 mouse to the system.
5	PS/2 keyboard connector		Allows you to connect a PS/2 keyboard to the system.
6	Display ports (2)		Allow you to connect other external display devices to the system.

Item	Indicator, Button, or Connector	Icon	Description
7	USB connectors (2)		Allow you to connect USB devices to the system. The ports are USB 3.0 compliant.
8	Video connector		Allows you to connect a VGA display to the system.
9	Line-out connector		Allows you to connect other output devices to the system.
10	Line-in/microphone connector		Allows you to connect other external audio devices to the system.
11	Expansion card slots (4)		Allow you to connect up to three full-height PCIe expansion cards and one full-height PCI expansion card.
12	Security-cable slot		Allows you to connect a cable lock to the system.
13	Padlock ring		Locks the cover release latch.
14	Ethernet connector		One integrated 10/100/1000 Mbps NIC connector.
15	USB connectors (4)		Allow you to connect USB devices to the system. The ports are USB 2.0 compliant.
16	Serial connector		Allows you to connect a serial device to the system.

NIC Indicator Codes

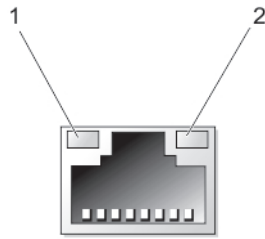

Figure 3. NIC Indicator Codes

1. link indicator
2. activity indicator

Indicator	Indicator Code
Link integrity light on integrated network adapter	Green — a good 10 Mbps connection exists between the network and the system.
	Green — a good 100 Mbps connection exists between the network and the system.
	Orange — a good 1000 Mbps connection exists between the network and the system.
	Off (no light) — the system is not detecting a physical connection to the network.

Indicator	Indicator Code
Network activity light on integrated network adapter	Yellow light — A blinking yellow light indicates that network activity is present.

Power Indicator Codes For Power Supply

Press the self-diagnostic button to perform a quick health check on the non-redundant power supply of the system.

Diagnostic Indicator Pattern	Condition
Not lit	Power is not connected or power supply is faulty.
Green	A valid power source is connected to the power supply and the power supply is operational.

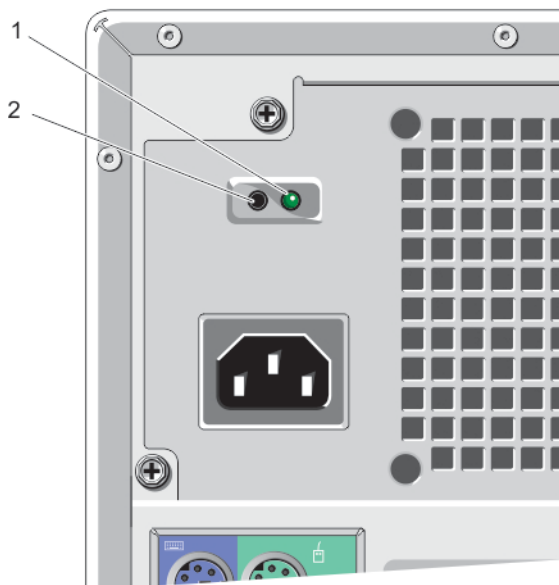

Figure 4. Power Supply Status Indicator and Self-Diagnostic Button

1. AC power supply status indicator
2. self-diagnostic button

Complete The Operating System Setup

To install an operating system for the first time, see the installation and configuration documentation for your operating system. Be sure that the operating system is installed before installing hardware or software not purchased with the system.

Supported Operating Systems

The following operating systems are supported:

- Microsoft Windows Server 2012

- Red Hat Enterprise Linux 6.5 and later

 **NOTE:** For latest information on supported operating systems, see dell.com/ossupport.

Other Information You May Need

 **WARNING:** See the safety and regulatory information that shipped with your system. Warranty information may be included within this document or as a separate document.

- The Owner's Manual provides information about system features and describes how to troubleshoot the system and install or replace system components. This document is available online at www.dell.com/poweredgemanuals.
- Any media that ships with your system that provides documentation and tools for configuring and managing your system, including those pertaining to the operating system, system management software, system updates, and system components that you purchased with your system.
- For latest information on supported operating systems, see dell.com/ossupport.

 **NOTE:** Always check for updates on dell.com/support/manuals and read the updates first because they often supersede information in other documents.

 **NOTE:** When upgrading your system, it is recommended that you download and install the latest BIOS, driver, and systems management firmware on your system from dell.com/support.

Using The System Setup And Boot Manager

System Setup enables you to manage your system hardware and specify BIOS-level options.

The following keystrokes provide access to system features during startup:

Keystroke	Description
<F2>	Enters the System Setup.
<F12>	Enters the Boot Manager.

From the System Setup, you can:

- Change the NVRAM settings after you add or remove hardware
- View the system hardware configuration
- Enable or disable integrated devices
- Set performance and power management thresholds
- Manage system security

From the Boot Manager, you can:

- Verify the boot mode and the secure boot status
- Select a one-time boot device
- Perform hardware diagnostics
- Configure the Intel Management Engine BIOS Extension
- Update the BIOS

Choosing The System Boot Mode

System Setup enables you to specify the boot mode for installing your operating system:

- Legacy boot mode (the default) is the standard BIOS-level boot interface.
- Unified Extensible Firmware Interface (UEFI) boot mode is an enhanced 64-bit boot interface based on UEFI specifications that overlays the system BIOS.

In **System Setup**, select boot mode in the **Boot List Option** field of the **Boot Sequence** screen. Once you specify the boot mode, the system boots in the specified boot mode and then proceeds to install your operating system from that mode. Thereafter, you must boot the system in the same boot mode (Legacy or UEFI) to access the installed operating system. Trying to boot the operating system from the other boot mode will cause the system to halt at startup.

 **NOTE:** Operating systems must be UEFI-compatible to be installed from the UEFI boot mode. DOS and 32-bit operating systems do not support UEFI and can only be installed from the Legacy boot mode.

 **NOTE:** For the latest information on supported operating systems, go to dell.com/ossupport.

Entering System Setup

1. Turn on or restart your system.
2. Press <F2>. If your operating system begins to load before you press <F2>, allow the system to finish booting, and then restart your system and try again.



Using The System Setup Navigation Keys

Key	Description
Up arrow	Moves to the previous field.
Down arrow	Moves to the next field.
<Enter>	Allows you to type in a value in the selected field (if applicable) or follow the link in the field.
Spacebar	Expands or collapses a drop-down list, if applicable.
<Tab>	Moves to the next focus area.
	 NOTE: For the standard graphics browser only.
<Esc>	Moves to the previous page till you view the main screen. Pressing <Esc> in the main screen exits the Boot Manager and proceeds with system boot.

 **NOTE:** For most of the options, any changes that you make are recorded but do not take effect until you restart the system.

Updating The BIOS

It is recommended to update your BIOS (system setup), on replacing the system board or if an update is available.

1. Restart the system.
2. Go to dell.com/support.
3. If you do not have your system's Service Tag or Express Service Code:
4. Enter the Service Tag or Express Service Code and click **Submit**.
 **NOTE:** To locate the Service Tag, click **Where is my Service Tag?**
 **NOTE:** If you cannot find your Service Tag, click **Detect Service Tag**. Proceed with the instructions on screen.
5. If you are unable to locate or find the Service Tag, click the product category of your system.
6. Choose the product type from the list.
7. Select your system model and the product support page of your system is displayed.
8. Click **Drivers & Downloads**.
9. On the **Drivers and Downloads** screen, under the **Operating System** drop-down list, select **BIOS**.
10. Identify the latest BIOS file and click **Download File**.
11. Select your preferred download method in the **Please select your download method below** window and click **Download File**.
The **File Download** window is displayed.
12. Click **Save** to save the file on your system.

- Click **Run** to install the updated BIOS settings on your system.
Follow the instructions on the screen.

Responding To Error Messages

If an error message is displayed while the system is booting, make a note of the message. For more information, see [System Messages](#).

 **NOTE:** After installing a memory upgrade, it is normal for your system to display a message the first time you start your system.

System Setup Options

 **NOTE:** Depending on the system and its installed devices, the items listed in this section may or may not .

Table 1. General



Option	Description
System Information	<p>Displays the following information:</p> <ul style="list-style-type: none"> System Information — Displays BIOS Version, Service Tag, Asset Tag, Ownership Tag, Ownership Date, Manufacture Date, and the Express Service Code. Memory Information — Displays Memory Installed, Memory Available, Memory Speed, Memory Channels Mode, Memory Technology, DIMM 1 Size, DIMM 2 Size, DIMM 3 Size, and DIMM 4 Size. PCI Information — Displays SLOT1, SLOT2, SLOT3, and SLOT4. Processor Information — Displays Processor Type, Core Count, Processor ID, Current Clock Speed, Maximum Clock Speed, Processor L2 Cache, Processor L3 Cache, HT Capable, and 64-Bit Technology. Device Information — Displays SATA-0, SATA-1, SATA-2, SATA-3, LOM MAC Address, Audio Controller, and Video Controller.
Boot Sequence	<p>Boot Sequence — Allows you to specify the order in which the system attempts to find an operating system. The options are:</p> <ul style="list-style-type: none"> Diskette drive STXXXXXX / STXXXXXX USB storage device CD/DVD/CD-RW drive Onboard NIC <p>Boot List Option — Allows you to choose or change the boot mode for installing your operating system. The options are:</p> <ul style="list-style-type: none"> Legacy UEFI <p> NOTE: If you boot the system to the BIOS boot mode after installing an operating system with UEFI boot mode, the system does not respond. You must boot to the same boot mode in which you installed the operating system.</p>
Advanced Boot Options	<p>Enable Legacy Option ROMs — This option is enabled by default.</p>
Date/Time	<p>Allows you to set the date and time. Changes to the system date and time take effect immediately.</p>

Table 2. System Configuration

Option	Description
Integrated NIC	<p>Allows you to enable or disable the integrated network card. You can set the integrated NIC to:</p> <ul style="list-style-type: none">• Disabled• Enabled• Enabled w/PXE (this option is enabled by default)• Enable UEFI Network Stack <p> NOTE: Depending on the system and the devices installed, the items listed in this section may or may not be displayed.</p>
Serial Port	<p>Allows you to define the serial port settings. You can set the serial port to:</p> <ul style="list-style-type: none">• Disabled• COM1• COM2• COM3• COM4 <p> NOTE: The operating system may allocate resources even though the setting is disabled.</p>
SATA Operation	<p>Allows you to configure the operating mode of the integrated hard-drive controller.</p> <ul style="list-style-type: none">• Disabled — The SATA controllers are hidden.• ATA — SATA is configured for ATA mode.• AHCI — SATA is configured for AHCI mode.• RAID ON — SATA is configured to support RAID mode.
Drives	<p>Allows you to enable or disable the various on-board drives:</p> <ul style="list-style-type: none">• SATA-0• SATA-1• SATA-2• SATA-3
SMART Reporting	<p>This field controls if the hard drive errors for the integrated drives are reported during system startup. This technology is part of the SMART (Self Monitoring Analysis and Reporting Technology) specification.</p> <ul style="list-style-type: none">• Enable SMART Reporting — This option is disabled by default.
USB Configuration	<p>This field configures the integrated USB controller. If Boot Support is enabled, the system is allowed to boot any type of USB mass storage devices (HDD, memory key, floppy).</p> <p>If the USB port is enabled, the device attached to this port is enabled and available for the operating system.</p> <p>If the USB port is disabled, the operating system cannot see any device attached to this port.</p> <p>The options for USB configuration may differ based on the form factors:</p> <ul style="list-style-type: none">• Enable Boot Support



Option	Description
	<ul style="list-style-type: none"> • Enable Front USB 2.0 Ports • Enable USB 3.0 Ports • Enable Rear–Left Dual USB 2.0 Ports • Enable Rear–Right Dual USB 2.0 Ports (this option is enabled by default) <p> NOTE: USB keyboard and mouse always work in the BIOS setup irrespective of these settings.</p>
Audio	<p>Allows you to enable or disable the integrated audio controller.</p> <ul style="list-style-type: none"> • Enable Audio — This option is enabled by default.
Miscellaneous Devices	<p>Allows you to enable or disable various on-board devices.</p> <ul style="list-style-type: none"> • Enable PCI Slot — This option is enabled by default.

Table 3. Security

Option	Description
Admin Password	<p>This field lets you set, change, or delete the administrator (admin) password (sometimes called the setup password). The Admin Password enables several security features.</p> <ol style="list-style-type: none"> 1. Enter the old password. 2. Enter the new password. 3. Confirm the new password. <p>The password is not set by default.</p>
System Password	<p>This field lets you set, change, or delete the system password (previously called the primary password). The System Password enables several security features.</p> <ol style="list-style-type: none"> 1. Enter the old password. 2. Enter the new password. 3. Confirm the new password. <p>The password is not set by default.</p>
Internal HDD_0 Password	<p>This option lets you set, change, or delete the password on the system's internal hard disk drive. The Internal HDD_0 Password enables several security features.</p> <ol style="list-style-type: none"> 1. Enter the old password. 2. Enter the new password. 3. Confirm the new password. <p>The drive does not have a password set by default.</p>
Strong Password	<p>Enable strong password — This option is disabled by default.</p>
Password Configuration	<p>This field controls the minimum and maximum number of characters allowed for the admin and system passwords.</p> <ul style="list-style-type: none"> • Admin Password Min • Admin Password Max • System Password Min

Option	Description
Password Bypass	<ul style="list-style-type: none"> • System Password Max <p>Allows you to bypass the System Password and the internal HDD password prompts during a system restart.</p> <ul style="list-style-type: none"> • Disabled — Always prompt for the system and internal HDD password when they are set. This option is disabled by default. • Reboot Bypass — Bypass the password prompts on restarts (warm boots). <p> NOTE: The system always prompts for the system and internal HDD passwords when powered on from the off state (a cold boot). Also, the system always prompts for passwords on any module bay HDDs that may be present.</p>
Password Change	<p>Allows you to determine whether changes to the system and hard disk passwords are permitted when an administrator password is set.</p> <ul style="list-style-type: none"> • Allow Non-Admin Password Changes — This option is enabled by default.
TPM Security	<p>This option lets you control whether the Trusted Platform Module (TPM) in the system is enabled and visible to the operating system.</p> <p>TPM Security — This option is disabled by default.</p> <p>When the TPM Security option is enabled, it displays the following advanced options:</p> <ul style="list-style-type: none"> • TPM ACPI Support • TPM PPI Deprovision Override • Clear • TPM PPI Provision Override <p> NOTE: Activation, deactivation, and clear options are not affected if you load the setup program's default values. Changes to the TPM Security option take effect immediately.</p>
Computrace(R)	<p>This field lets you activate or disable the BIOS module interface of the optional Computrace Service from Absolute Software.</p> <ul style="list-style-type: none"> • Deactivate — This option is disabled by default. • Disable • Activate
Chassis-Intrusion	<p>Allows you to enable or disable the chassis-intrusion alert.</p> <ul style="list-style-type: none"> • Disable • Enable • On-Silent — This option is enabled by default. <p>Once a chassis intrusion has been detected, the system will add the chassis-intrusion alert into the BIOS events at each cold/warm boot. The following option will then be displayed:</p> <ul style="list-style-type: none"> • Clear Intrusion Warning — This option allows you to acknowledge and clear the chassis-intrusion status.
Processor XD Support	<p>Allows you to enable or disable the execute disable mode of the processor.</p>

Option	Description
	<ul style="list-style-type: none"> • Enable processor XD Support — This option is enabled by default.
OROM Keyboard Access	<p>Allows you to determine if you access the Option Read Only Memory (OROM) configuration screens via hotkeys during boot. These settings prevent access to the Intel RAID (CTRL+I) or Intel Management Engine BIOS Extension (CTRL+P/F12).</p> <ul style="list-style-type: none"> • Enable — User may enter OROM configuration screens via the hotkey. • One-Time Enable — User can enter the OROM configuration screens via the hotkeys during the next boot. After the boot, the setting will revert to disabled. • Disable — User cannot enter the OROM configuration screens via the hotkey. <p>The OROM Keyboard Access option is set to Enable by default.</p>
Admin Setup Lockout	<p>Allows you to enable or disable the option to enter setup when an admin password is set.</p> <ul style="list-style-type: none"> • Enable Admin Setup Lockout — This option is not set by default.

Table 4. Secure Boot



Option	Description
Secure Boot Enable	<p>Allows you to enable or disable Secure Boot feature.</p> <ul style="list-style-type: none"> • Disable • Enable <p> NOTE: For Secure Boot to be enabled the system has to be in the UEFI boot mode and the Enable Legacy Option ROMs needs to be turned off.</p>
Expert Key Management	<p>Allows you to manipulate the security key databases only if the system is in Custom Mode. The Enable Custom Mode option is disabled by default. The options are:</p> <ul style="list-style-type: none"> • PK • KEK • db • dbx <p>If you enable the Custom Mode, the relevant options for PK, KEK, db, and dbx are displayed. The options are:</p> <ul style="list-style-type: none"> • Save to File — Saves the key to a user-selected file. • Replace from File — Replaces the current key with a key from a user-selected file. • Append from File — Adds a key to the current database from a user-selected file. • Delete — Deletes the selected key. • Reset All Keys — Resets to default setting. • Delete All Keys — Deletes all the keys. <p> NOTE: If you disable the Custom Mode, all the changes will be erased and the keys will restore to default settings.</p>

Table 5. Performance

Option	Description
Multi Core Support	<p>Specifies whether the processor will have one or all cores enabled. The performance of some applications will improve with the additional cores.</p> <ul style="list-style-type: none"> • All — Enabled by default. • 1 • 2
Intel SpeedStep	<p>Allows you to enable or disable the Intel SpeedStep mode of the processor. This option is enabled by default.</p>
C States Control	<p>Allows you to enable or disable the additional processor sleep states. This option is enabled by default.</p>
Limit CPUID Value	<p>This field limits the maximum value the processor standard CPUID function will support.</p> <ul style="list-style-type: none"> • Enable CPUID Limit — This option is disabled by default. <p> NOTE: Some operating systems will not complete installation when the maximum CPUID function is greater than three.</p>
Intel TurboBoost	<p>Allows you to enable or disable Intel TurboBoost mode of the processor.</p> <ul style="list-style-type: none"> • Disabled — Does not allow the Intel TurboBoost driver to increase the performance state of the processor above the standard performance. • Enabled — Allows the Intel TurboBoost driver to increase the performance of the processor or graphics processor.
Hyper-Thread Control	<p>Allows you to enable or disable the Hyper-Threading technology. This option is enabled by default.</p>

Table 6. Power Management

Option	Description
AC Recovery	<p>Specifies how the system will respond when AC power is applied after an AC power loss. You can set the AC Recovery to:</p> <ul style="list-style-type: none"> • Power Off • Power On • Last Power State
Auto On Time	<p>This option sets the time of the day when you would like the system to turn on automatically. Time is kept in standard 12-hour format (hour:minutes:seconds). The startup time can be changed by typing the values in the time and A.M./P.M. fields.</p> <ul style="list-style-type: none"> • Disabled — The system will not automatically power up. • Every Day — The system will power up every day at the time you specified above. • Weekdays — The system will power up Monday through Friday at the time you specified above. • Select Days — The system will power up on days selected above at the time you specified above.



Option	Description
	 NOTE: This feature does not work if you turn off your system using the switch on a power strip or surge protector or if Auto Power is set to disabled.
Deep Sleep Control	<p>Allows you to define the controls when Deep Sleep is enabled.</p> <ul style="list-style-type: none"> • Disabled • Enabled in S5 only • Enabled in S4 and S5 <p>This option is disabled by default.</p>
Fan Control Override	<p>Controls the speed of the system fan. This option is disabled by default.</p>  NOTE: When enabled, the fan runs at full speed.
USB Wake Support	<p>This option allows you to enable USB devices to wake the system from standby.</p> <ul style="list-style-type: none"> • Enable USB Wake Support — This option is disabled by default.
Wake on LAN	<p>This option allows the system to power up from the off state when triggered by a special LAN signal. Wakeup from the Standby state is unaffected by this setting and must be enabled in the operating system. This feature only works when the system is connected to AC power supply. The options differ based on the form factor.</p> <ul style="list-style-type: none"> • Disabled — Does not allow the system to power on by special LAN signals when it receives a wakeup signal from the LAN or wireless LAN. • LAN Only — Allows the system to be powered on by special LAN signals. • LAN with PXE Boot — Allows the system to be powered on by special LAN or PXE boot signals. <p>This option is disabled by default.</p>
Block Sleep	<p>This option lets you block entering to sleep (S3 state) in operating system environment.</p> <ul style="list-style-type: none"> • Block Sleep (S3 state) — This option is disabled by default.

Table 7. POST Behavior

Option	Description
Numlock LED	Specifies if the NumLock function can be enabled when the system boots. This option is enabled by default.
Keyboard Errors	Specifies whether keyboard related errors are reported when it boots. This option is enabled by default.
MEBx Hotkeys	<p>Specifies whether the MEBx Hotkey function should be enabled when the system boots.</p> <ul style="list-style-type: none"> • Enable MEBx Hotkey — This option is enabled by default.

Table 8. Virtualization Support



Option	Description
Virtualization	<p>This option specifies whether a Virtual Machine Monitor (VMM) can utilize the additional hardware capabilities provided by Intel Virtualization technology.</p> <ul style="list-style-type: none"> • Enable Intel Virtualization Technology — This option is enabled by default.
VT for Direct I/O	<p>Enables or disables the VMM from utilizing the additional hardware capabilities provided by Intel Virtualization technology for direct I/O.</p> <ul style="list-style-type: none"> • Enable Intel Virtualization Technology for Direct I/O — This option is enabled by default. <p> NOTE: This is supported only on Intel Xeon processor-based systems.</p>
Trusted Execution	<p>This option specifies whether a Measured Virtual Machine Monitor (MVMM) can utilize the additional hardware capabilities provided by Intel Trusted Execution technology. The TPM virtualization technology and virtualization technology for direct I/O must be enabled to use this feature.</p> <ul style="list-style-type: none"> • Trusted Execution — This option is disabled by default. <p> NOTE: This is supported only on Intel Xeon processor-based systems.</p>

Table 9. Maintenance

Option	Description
Service Tag	Displays the service tag of your system.
Asset Tag	Allows you to create a system asset tag if an asset tag is not already set. This option is not set by default.
SERR Messages	Controls the SERR message mechanism. This option is not set by default. Some graphics cards require that the SERR message mechanism be disabled.

Table 10. System Logs

Option	Description
BIOS events	<p>Displays the system event log and allows you to clear the log.</p> <ul style="list-style-type: none"> • Clear Log

Boot Manager Screen

Option	Description
LEGACY/UEFI BOOT	Allows you to select a one-time boot device from bootable devices list.
OTHER OPTIONS	
BIOS Setup	Enters System Setup.
BIOS Flash Update	Allows you to update the BIOS from the USB drive with the released BIOS file. This option is for advanced users.

Option	Description
	<ol style="list-style-type: none"> 1. Download the BIOS file from dell.com/support. For more information, see Updating The BIOS. 2. Save the BIOS file on a USB drive (FAT32). 3. Press <F12> while powering up the system to select the BIOS Flash Update. 4. Insert the USB drive into the USB port. 5. Select the BIOS file and proceed to the update.
Diagnostics	Allows you to enter the System Diagnostics. For more information, see Using System Diagnostics .
Intel Management Engine BIOS Extension	Allows you to configure Intel MEBX.
Change Boot Mode Settings	Allows you to change the boot mode (Legacy/UEFI).  NOTE: If you boot the system to the BIOS boot mode after installing an operating system from the UEFI Boot Manager, the system hangs. The reverse is also true. You must boot to the same boot mode in which you installed the operating system.

Using The Boot Manager Navigation Keys

Key	Description
Up arrow	Moves to the previous field.
Down arrow	Moves to the next field.
<Enter>	Allows you to type in a value in the selected field (if applicable) or follow the link in the field.
<Esc>	Moves to the previous page till you view the main screen. Pressing <Esc> in the main screen exits the Boot Manager and proceeds with system boot.

 **NOTE:** For most of the options, any changes that you make are recorded but do not take effect until you restart the system.

System And Admin Password Features

You can create a system password and a admin password to secure your system. To create a system and admin password, the password jumper must be set to enabled. For more information on the password jumper settings, see [System Board Jumper Settings](#).

System password	This is the password that you must enter before you boot your system.
Admin password	This is the password that you must enter to access and make changes to the BIOS or UEFI settings of your system.

 **CAUTION:** The password features provide a basic level of security for the data on your system.

 **CAUTION:** Anyone can access the data stored on your system if the system is running and unattended.

 **NOTE:** Your system is shipped with the system and admin password feature disabled.

Assigning A System Password And Admin Password

You can assign a new **System Password** and/or **Admin Password** or change an existing **System Password** and/or **Admin Password** only when **Password Status** is **Unlocked**. If the **Password Status** is **Locked**, you cannot change the **System Password**.

 **NOTE:** If the password jumper is disabled, the existing **System Password** and **admin Password** is deleted. You do not need to provide the system password to log on to the system.

To enter the System Setup, press <F2> immediately after a power-on or reboot.

1. In the **System BIOS** or **System Setup** screen, select **Security** and press <Enter>. The **Security** screen is displayed.
2. Select **System Password**, enter your system password, and press <Enter> or <Tab>. Use the following guidelines to assign the system password:
 - A password can have up to 32 characters.
 - The password can contain the numbers 0 through 9.
 - Only the following special characters are allowed: space, ("), (+), (,), (-), (.), (/), (;), ([, \), (]), (').
3. Re-enter the system password that you entered earlier and click **OK**.
4. Select **Admin Password**, enter your system password and press <Enter> or <Tab>. A message prompts you to retype the admin password.
5. Re-enter the admin password that you entered earlier and click **OK**.
6. Press <Esc> and a message prompts you to save the changes.
7. Press <Y> to save the changes and exit from the System Setup. The system reboots.

Deleting Or Changing An Existing System And Admin Password

Ensure that the **Password Status** is **Unlocked** (in the System Setup) before attempting to delete or change the existing System and/or admin password. You cannot delete or change an existing System or admin password, if the **Password Status** is **Locked**.

To enter System Setup, press <F2> immediately after a power-on or reboot.

1. In the **System BIOS** or **System Setup** screen, select **Security** and press <Enter>. The **Security** screen is displayed.
2. Select **System Password**, alter or delete the existing system password and press <Enter> or <Tab>.
3. Select **Admin Password**, alter or delete the existing admin password and press <Enter> or <Tab>.

 **NOTE:** If you change the system and/or admin password, re-enter the new password when promoted. If you delete the system and/or admin password, confirm the deletion when promoted.
4. Press <Esc> and a message prompts you to save the changes.
5. Press <Y> to save the changes and exit from the System Setup. The system reboots.

Intel Active Management Technology

Intel Active Management Technology (AMT) enables you to remotely manage, diagnose, and repair the managed server.

 **NOTE:** Intel AMT is supported only on Intel Xeon processor-based systems.

It provides the following features:

- Allows you to discover devices even while the system is powered off.
- With out-of-band management capabilities, you can remotely remediate and recover systems after OS failures.
- Blocks incoming threats and infected clients before they affect the network.
- Provides remote hardware and software asset tracking.

For more information on Intel AMT, see www.intel.com/amt.

Installing System Components

Recommended Tools

You may need the following items to perform the procedures in this section:

- #1 and #2 Phillips screwdrivers
- Wrist grounding strap connected to ground

Opening And Closing The System

 **WARNING:** Whenever you need to lift the system, get others to assist you. To avoid injury, do not attempt to lift the system by yourself.

 **WARNING:** Opening or removing the system cover when the system is on may expose you to a risk of electric shock.

 **NOTE:** It is recommended that you always use a static mat and static strap while working on components in the interior of the system.

 **CAUTION:** Many repairs may only be done by a certified service technician. You should only perform troubleshooting and simple repairs as authorized in your product documentation, or as directed by the online or telephone service and support team. Damage due to servicing that is not authorized by Dell is not covered by your warranty. Read and follow the safety instructions that came with the product.

 **CAUTION:** Do not operate the system without the cover for a duration exceeding five minutes.

Opening The System

1. Turn off the system, including any attached peripherals, and disconnect the system from the electrical outlet and peripherals.
2. Lay the system on its side, on a flat and stable surface.
3. Lift the cover release latch and remove the cover away from the system.

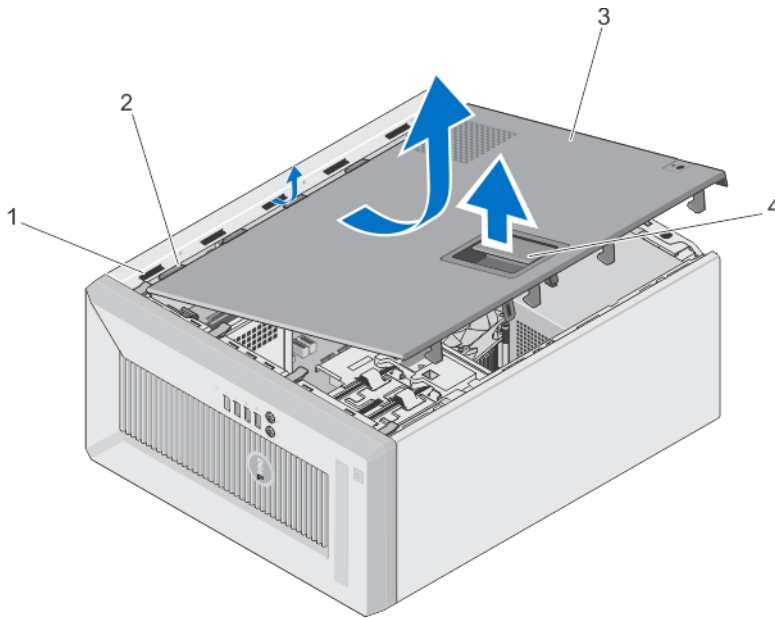

Figure 5. Opening and Closing the System

1. slots
2. tabs
3. system cover
4. cover release latch

Closing The System

1. Ensure that all internal cables are connected and placed out of the way and that no tools or extra parts are left inside the system.
2. Align the tabs on the system cover with the corresponding slots on the system chassis.
3. Lower the system cover onto the chassis until it clicks into place.
4. Place the system upright on a flat, stable surface.
5. Reconnect the system to its electrical outlet and turn the system on, including any attached peripherals.

Bezel

Removing The Bezel

1. Turn off the system, including any attached peripherals, and disconnect the system from the electrical outlet and peripherals.
2. Lay the system on its side, on a flat and stable surface.
3. Open the system.
4. Lift the retention clips located at the edge of the bezel.
5. Rotate the bezel away from the system to release the tabs on the bottom of the bezel.

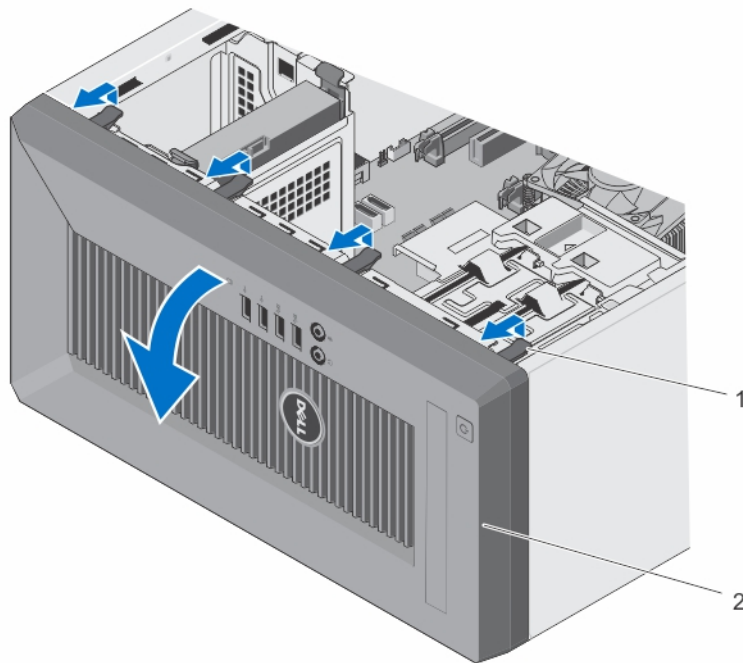

Figure 6. Removing and Installing the Bezel

1. retention clips (4)
2. bezel

Installing The Bezel

1. Insert the bezel tabs into the bezel tab slots in the chassis.
2. Press the bezel into the chassis until the bezel locks into place.
3. Close the system.
4. Place the system upright on a flat, stable surface.

Chassis-Intrusion Switch

The chassis-intrusion switch detects any unauthorized access into the interior of your system and provides an indication of the same. This switch is activated as soon as the system cover is removed and access is made to the interior of your system.

Removing The Chassis-Intrusion Switch

△ CAUTION: Many repairs may only be done by a certified service technician. You should only perform troubleshooting and simple repairs as authorized in your product documentation, or as directed by the online or telephone service and support team. Damage due to servicing that is not authorized by Dell is not covered by your warranty. Read and follow the safety instructions that came with the product.

1. Turn off the system, including any attached peripherals, and disconnect the system from the electrical outlet and peripherals.
2. Lay the system on its side, on a flat and stable surface.
3. Open the system.
4. Disconnect the chassis-intrusion switch cable from the system board.
5. Slide the chassis-intrusion switch and push it out of the chassis-intrusion switch slot.

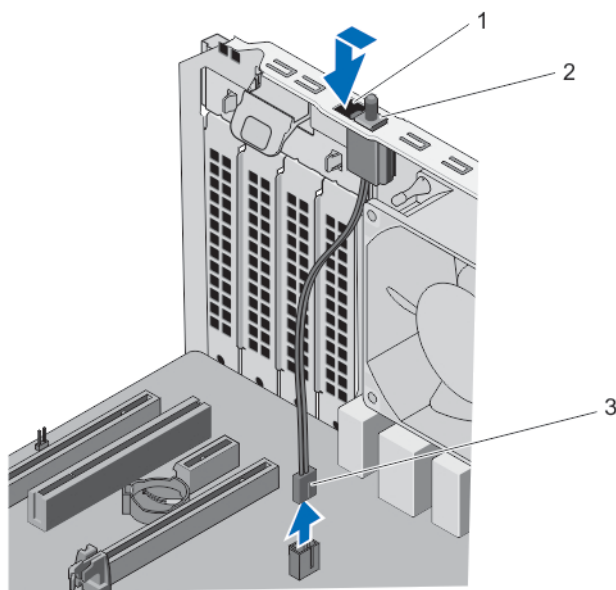

Figure 7. Removing and Installing the Chassis-Intrusion Switch

1. chassis-intrusion switch slot
2. chassis-intrusion switch
3. chassis-intrusion switch cable

Installing The Chassis-Intrusion Switch

△ CAUTION: Many repairs may only be done by a certified service technician. You should only perform troubleshooting and simple repairs as authorized in your product documentation, or as directed by the online or telephone service and support team. Damage due to servicing that is not authorized by Dell is not covered by your warranty. Read and follow the safety instructions that came with the product.

1. Turn off the system, including any attached peripherals, and disconnect the system from the electrical outlet and peripherals.
2. Lay the system on its side, on a flat and stable surface.

3. Open the system.
4. Insert the chassis-intrusion switch into the chassis-intrusion switch slot and slide it to secure it.
5. Connect the chassis-intrusion switch cable to the system board.
6. Close the system.

Inside The System

CAUTION: Many repairs may only be done by a certified service technician. You should only perform troubleshooting and simple repairs as authorized in your product documentation, or as directed by the online or telephone service and support team. Damage due to servicing that is not authorized by Dell is not covered by your warranty. Read and follow the safety instructions that came with the product.

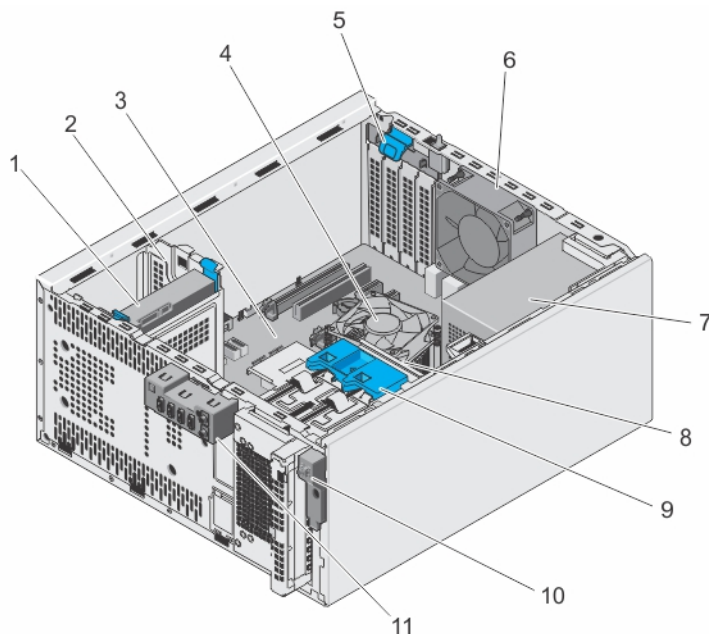

Figure 8. Inside the System

- | | | | |
|----|----------------------|-----|-----------------------|
| 1. | hard drive | 7. | power supply unit |
| 2. | hard-drive bay | 8. | hard-drive cage |
| 3. | system board | 9. | hard-drive cage latch |
| 4. | heat-sink assembly | 10. | power switch |
| 5. | expansion-card latch | 11. | I/O panel |
| 6. | system fan | | |

Thermal Sensor

Removing The Thermal Sensor

△ CAUTION: Many repairs may only be done by a certified service technician. You should only perform troubleshooting and simple repairs as authorized in your product documentation, or as directed by the online or telephone service and support team. Damage due to servicing that is not authorized by Dell is not covered by your warranty. Read and follow the safety instructions that came with the product.

1. Turn off the system, including any attached peripherals, and disconnect the system from the electrical outlet and peripherals.
2. Lay the system on its side, on a flat and stable surface.
3. Open the system.
4. Disconnect the thermal-sensor connector from the system board.
5. Remove the thermal-sensor cable from the chassis clip.
6. Press the tabs on the thermal sensor and remove the thermal sensor from the chassis.

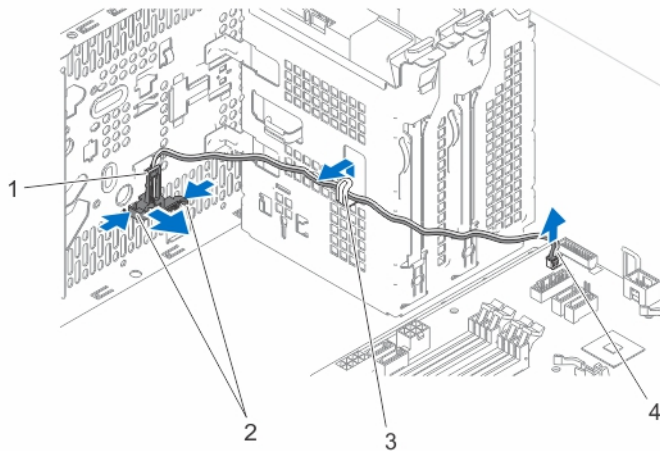

Figure 9. Removing and Installing the Thermal Sensor

1. thermal sensor
2. tabs (2)
3. chassis clip
4. thermal-sensor connector

Installing The Thermal Sensor

△ CAUTION: Many repairs may only be done by a certified service technician. You should only perform troubleshooting and simple repairs as authorized in your product documentation, or as directed by the online or telephone service and support team. Damage due to servicing that is not authorized by Dell is not covered by your warranty. Read and follow the safety instructions that came with the product.

1. Turn off the system, including any attached peripherals, and disconnect the system from the electrical outlet and peripherals.
2. Lay the system on its side, on a flat and stable surface.

3. Open the system.
4. Align the tabs with the thermal-sensor slot on the chassis and secure the thermal sensor to the chassis.
5. Route the thermal-sensor cable through the chassis clip and connect the thermal-sensor connector to the system board.
6. Close the system.
7. Place the system upright on a flat, stable surface.
8. Reconnect the system to its electrical outlet and turn the system on, including any attached peripherals.

Power Switch

Removing The Power Switch

⚠ CAUTION: Many repairs may only be done by a certified service technician. You should only perform troubleshooting and simple repairs as authorized in your product documentation, or as directed by the online or telephone service and support team. Damage due to servicing that is not authorized by Dell is not covered by your warranty. Read and follow the safety instructions that came with the product.

1. Turn off the system, including any attached peripherals, and disconnect the system from the electrical outlet and peripherals.
2. Lay the system on its side, on a flat and stable surface.
3. Open the system.
4. Remove the following components:
 - a) bezel
 - b) optical drive

For information on removing the optical drive, see [Removing The Optical Drive](#).

5. Disconnect the power-switch cable from the system board.
6. Remove the power-switch cable from the chassis clip.
7. Remove the screw securing the power switch to the chassis.
8. Slide the power switch down to disengage it from the slot and slide out the power switch from the system.

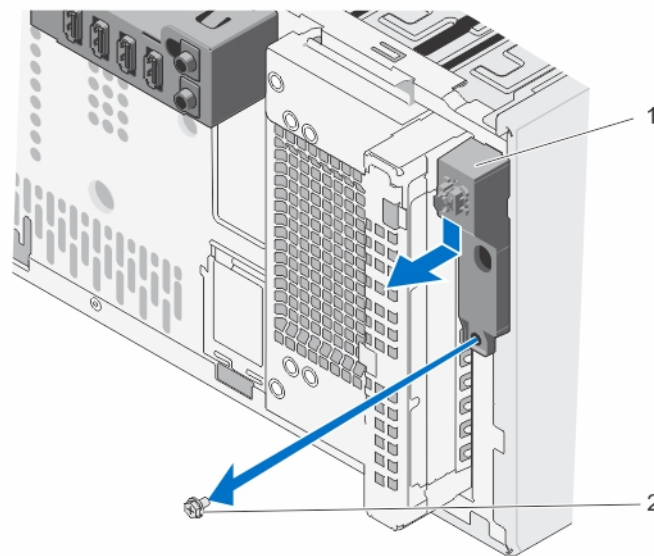



Figure 10. Removing and Installing the Power Switch

1. power switch
2. screw

Installing The Power Switch

 **CAUTION: Many repairs may only be done by a certified service technician. You should only perform troubleshooting and simple repairs as authorized in your product documentation, or as directed by the online or telephone service and support team. Damage due to servicing that is not authorized by Dell is not covered by your warranty. Read and follow the safety instructions that came with the product.**

1. Turn off the system, including any attached peripherals, and disconnect the system from the electrical outlet and peripherals.
2. Lay the system on its side, on a flat and stable surface.
3. Open the system.
4. Slide the power switch through the slot on the front of the system and secure it to the system.
5. Route the power-switch cable through the chassis clip.
6. Connect the power-switch cable to the power-switch connector on the system board.
7. Install the following components:
 - a) optical drive
For information on installing the optical drive, see [Installing The Optical Drive](#).
 - b) bezel
8. Close the system.
9. Place the system upright on a flat, stable surface.
10. Reconnect the system to its electrical outlet and turn the system on, including any attached peripherals.

Input/Output Panel

Removing The Input/Output Panel

 **CAUTION: Many repairs may only be done by a certified service technician. You should only perform troubleshooting and simple repairs as authorized in your product documentation, or as directed by the online or telephone service and support team. Damage due to servicing that is not authorized by Dell is not covered by your warranty. Read and follow the safety instructions that came with the product.**

1. Turn off the system, including any attached peripherals, and disconnect the system from the electrical outlet and peripherals.
2. Lay the system on its side, on a flat and stable surface.
3. Open the system.
4. Remove the bezel.
5. Disconnect the I/O panel, data, and USB data cables from the system board.
6. Remove the I/O panel, data, and USB data cables from the chassis clip.
7. Remove the screw securing the I/O panel to the system.
8. Slide the I/O panel towards the front of the system to release it and pull the I/O panel along with its cable out of the system.

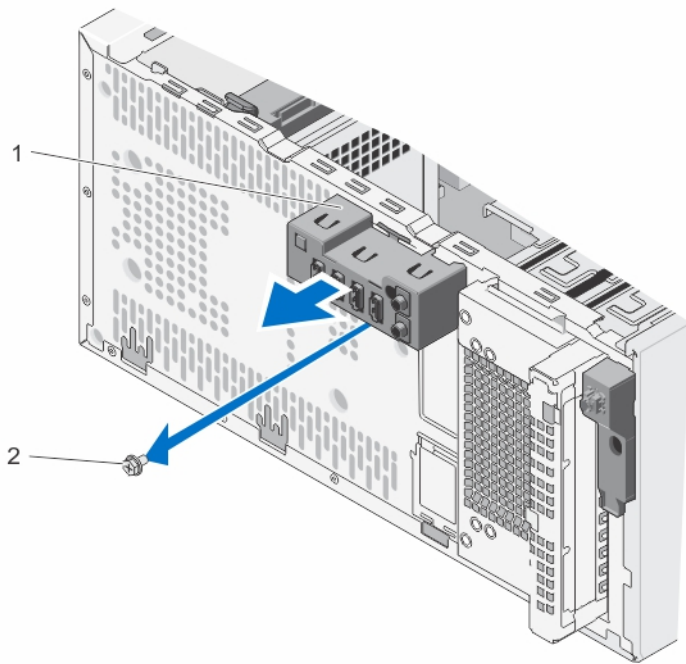

Figure 11. Removing and Installing the I/O Panel

1. I/O panel
2. screw

Installing The Input/Output Panel

⚠ CAUTION: Many repairs may only be done by a certified service technician. You should only perform troubleshooting and simple repairs as authorized in your product documentation, or as directed by the online or telephone service and support team. Damage due to servicing that is not authorized by Dell is not covered by your warranty. Read and follow the safety instructions that came with the product.

1. Turn off the system, including any attached peripherals, and disconnect the system from the electrical outlet and peripherals.
2. Lay the system on its side, on a flat and stable surface.
3. Open the system.
4. Insert the I/O panel into the slot on the front of the chassis.
5. Tighten the screw to secure the I/O panel to the chassis.
6. Route the I/O panel, data cable, and USB data cables through the chassis clip.
7. Connect the I/O panel, data cable, and USB data cables to the system board.
8. Install the bezel.
9. Close the system.
10. Place the system upright on a flat, stable surface.
11. Reconnect the system to its electrical outlet and turn the system on, including any attached peripherals.

Hard Drives

CAUTION: Do not turn off or reboot your system while the hard drive is being formatted. Doing so can cause a hard drive failure.

NOTE: Use only hard drives that have been tested and approved for use with your system.

NOTE: To install more than four drive devices (including optical drive and hard drives), you need an additional power extension cable, controller card, and SATA cables (minimum 1.6 ft).

NOTE: The screws used to secure the 2.5 inch hard drive to the hard-drive cage are available on the front of the hard-drive cage.

NOTE: Use the vertical type SATA cables to connect hard drives in the hard-drive cage to avoid damaging the connector pins. This is applicable for the 2.5 inch hard drives and optical drive.

NOTE: SATA cables that connect to the 3.5 inch hard drives in the hard-drive bay should be at a right angle to the hard-drive bay or you will not be able to close the system.

Removing The Hard-Drive Cage

CAUTION: Many repairs may only be done by a certified service technician. You should only perform troubleshooting and simple repairs as authorized in your product documentation, or as directed by the online or telephone service and support team. Damage due to servicing that is not authorized by Dell is not covered by your warranty. Read and follow the safety instructions that came with the product.

1. Turn off the system, including any attached peripherals, and disconnect the system from the electrical outlet and peripherals.
2. Lay the system on its side, on a flat and stable surface.
3. Open the system.
4. If applicable, remove the power and data cables from the hard drives in the hard-drive cage.
5. Remove the bezel.
6. Slide and hold the hard-drive cage latch and pull the hard-drive cage out of the system.

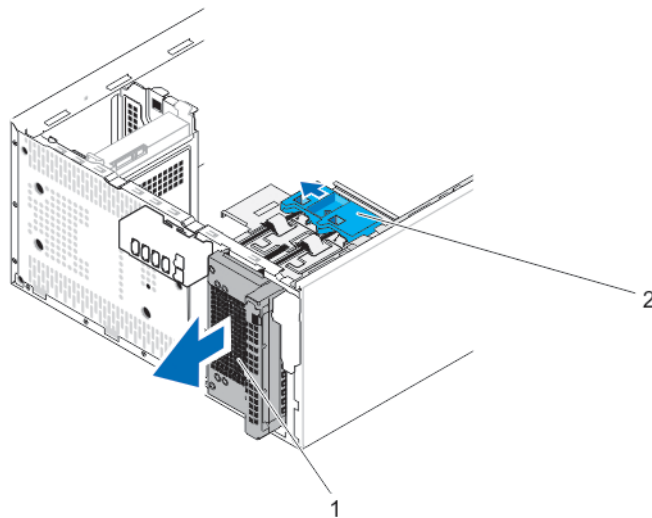



Figure 12. Removing and Installing the Hard-Drive Cage

1. hard-drive cage
2. hard-drive cage latch

Installing The Hard-Drive Cage

 **CAUTION:** Many repairs may only be done by a certified service technician. You should only perform troubleshooting and simple repairs as authorized in your product documentation, or as directed by the online or telephone service and support team. Damage due to servicing that is not authorized by Dell is not covered by your warranty. Read and follow the safety instructions that came with the product.

1. Turn off the system, including any attached peripherals, and disconnect the system from the electrical outlet and peripherals.
2. Lay the system on its side, on a flat and stable surface.
3. Open the system.
4. Insert the hard-drive cage into the system until it clicks into place.
5. If applicable, connect the power and data cables to the hard drives and optical drive in the hard-drive cage.
6. Install the bezel.
7. Close the system.
8. Place the system upright on a flat, stable surface.
9. Reconnect the system to its electrical outlet and turn the system on, including any attached peripherals.

Removing A 3.5 Inch Hard Drive From The Hard-Drive Cage

 **CAUTION:** Many repairs may only be done by a certified service technician. You should only perform troubleshooting and simple repairs as authorized in your product documentation, or as directed by the online or telephone service and support team. Damage due to servicing that is not authorized by Dell is not covered by your warranty. Read and follow the safety instructions that came with the product.

1. Turn off the system, including any attached peripherals, and disconnect the system from the electrical outlet and peripherals.
2. Lay the system on its side, on a flat and stable surface.
3. Open the system.
4. Remove the power and data cables from the hard drive in the hard-drive cage.
5. Remove the hard-drive cage.
For information on removing the hard-drive cage, see [Removing The Hard-Drive Cage](#).
6. Press the retention clips inwards and pull the hard drive out of the hard-drive cage.

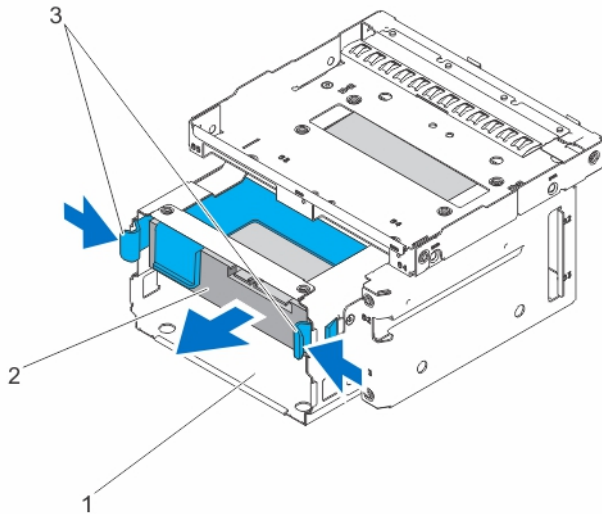

Figure 13. Removing and Installing a 3.5 Inch Hard Drive From The Hard-Drive Cage

1. hard-drive cage
2. hard drive
3. retention clips (2)

Installing A 3.5 Inch Hard Drive In The Hard-Drive Cage

CAUTION: Many repairs may only be done by a certified service technician. You should only perform troubleshooting and simple repairs as authorized in your product documentation, or as directed by the online or telephone service and support team. Damage due to servicing that is not authorized by Dell is not covered by your warranty. Read and follow the safety instructions that came with the product.

1. Turn off the system, including any attached peripherals, and disconnect the system from the electrical outlet and peripherals.
2. Open the system.
3. Remove the hard-drive cage from the system.

For information on removing the hard-drive cage, see [Removing The Hard-Drive Cage](#).

NOTE: If you have a 2.5 inch hard drive seated in the hard-drive cage, remove the power and data cables from the hard drive.

4. Align the ridges of the hard-drive carrier with the grooves on the hard-drive cage.
5. Insert the hard drive into the hard-drive cage until it clicks into place.
6. Install the hard-drive cage into the system.
7. Connect the power and data cables to the hard drive.

NOTE: For information on cabling the hard drives, refer to the System Information Label on the system cover.

NOTE: SATA cables that connect to the 3.5 inch hard drives in the hard-drive cage should be at a right angle to the hard-drive cage or you will not be able to close the system.

8. Close the system.
9. Reconnect the system to its electrical outlet and turn the system on, including any attached peripherals.
10. Reboot the system and press <F2> to enter the System Setup and ensure that the hard-drive controller is enabled.

11. Exit the System Setup program and reboot the system.
12. Install any software required for the hard drive operation as described in the documentation for the hard drive.

Removing A 2.5 Inch Hard Drive From The Hard-Drive Cage

CAUTION: Many repairs may only be done by a certified service technician. You should only perform troubleshooting and simple repairs as authorized in your product documentation, or as directed by the online or telephone service and support team. Damage due to servicing that is not authorized by Dell is not covered by your warranty. Read and follow the safety instructions that came with the product.

NOTE: If you install an optical drive you cannot install 2.5 inch hard drives.

1. Turn off the system, including any attached peripherals, and disconnect the system from the electrical outlet and peripherals.
2. Lay the system on its side, on a flat and stable surface.
3. Open the system.
4. Remove the power and data cables from the hard drive in the hard-drive cage.
5. Remove the hard-drive cage from the system.

For information on removing the hard-drive cage, see [Removing The Hard-Drive Cage](#).

NOTE: If you have a 3.5 inch hard drive seated in the hard-drive cage:

- a. Remove the power and data cables from the hard drive.
- b. Remove the hard drive from the hard-drive cage.

For information on removing a 3.5 inch hard drive, see [Removing A 3.5 Inch Hard Drive From The Hard-Drive Cage](#).

6. Turn the hard-drive cage over and remove the screws securing the hard drive to the hard-drive cage.

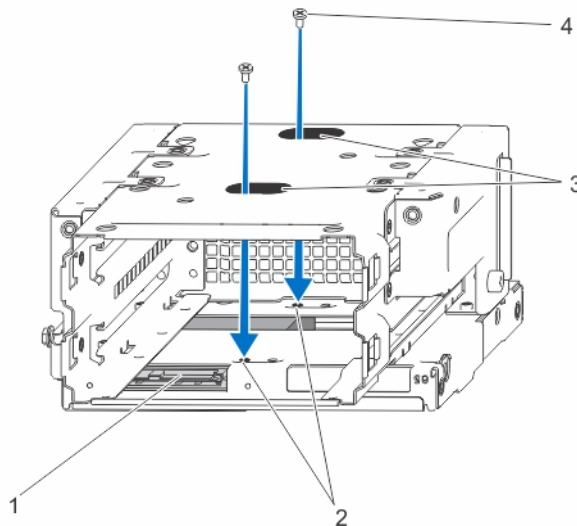

Figure 14. Removing and Installing the Hard-Drive Screws

1. hard drive
2. hard-drive screw sockets (4)
3. hard-drive screw slots (2)

4. hard-drive screws (4)
7. Turn the hard-drive cage.
8. Remove the screws on the sides of the hard-drive cage securing the hard drive to the hard-drive cage.
9. Lift and slide the hard drive out of the hard-drive cage.

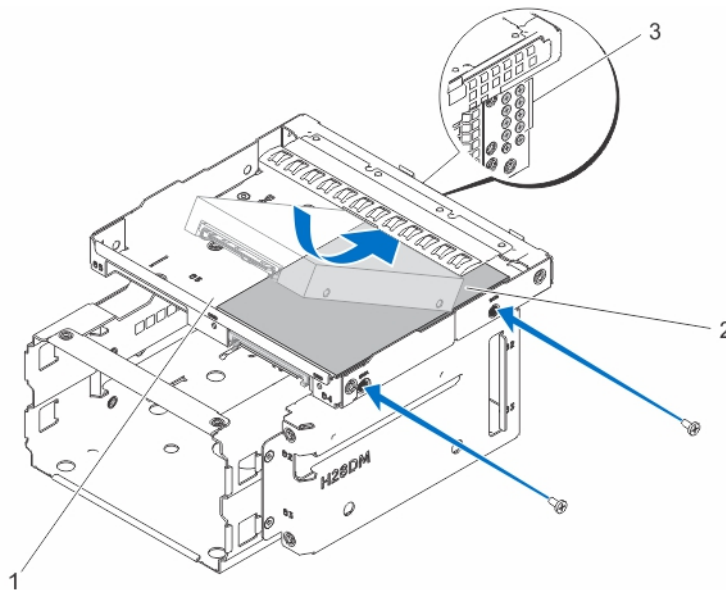

Figure 15. Removing and Installing the 2.5 Inch Hard Drive

1. hard-drive/optical-drive slot
2. hard drive
3. hard-drive screws (8)

NOTE: The screws used to secure the hard drive to the hard-drive cage are available on the front of the hard-drive cage as shown in callout 3.

Installing A 2.5 Inch Hard Drive In The Hard-Drive Cage

CAUTION: Many repairs may only be done by a certified service technician. You should only perform troubleshooting and simple repairs as authorized in your product documentation, or as directed by the online or telephone service and support team. Damage due to servicing that is not authorized by Dell is not covered by your warranty. Read and follow the safety instructions that came with the product.

1. Turn off the system, including any attached peripherals, and disconnect the system from the electrical outlet and peripherals.
2. Lay the system on its side, on a flat and stable surface.
3. Open the system.
4. Remove the power and data cables from the hard drive in the hard-drive cage.
5. Remove the hard-drive cage from the system.
For more information on removing the hard-drive cage, see [Removing The Hard-Drive Cage](#).

 **NOTE:** If you have a 3.5 inch hard drive seated in the hard-drive cage:

- a. Remove the power and data cables from the hard drive.
- b. Remove the hard drive from the hard-drive cage.

For more information on removing a 3.5 inch hard drive, see [Removing A 3.5 Inch Hard Drive From The Hard-Drive Cage](#).

6. Slide the hard drive into the hard-drive slot.

7. Tighten the screws on the sides of the hard-drive cage to secure the hard drive.

 **NOTE:** The screws used to secure the 2.5 inch hard drive to the hard-drive cage are available on the front of the hard-drive cage.

8. Turn the hard-drive cage over and tighten the screws on the bottom of the hard-drive cage to secure the hard drive.

9. Insert the hard-drive cage into the system.

10. Connect the power and data cables to the hard drive.

 **NOTE:** For information on cabling the hard drives, refer to the System Information Label on the system cover.

 **NOTE:** Use the vertical type SATA cables to connect hard drives in the hard-drive cage to avoid damaging the connector pins. This is applicable for the 2.5 inch hard drives and optical drive.

11. Close the system.

12. Place the system upright on a flat, stable surface.

13. Reconnect the system to its electrical outlet and turn the system on, including any attached peripherals.

14. Reboot the system and press <F2> to enter the System Setup and ensure that the hard drive controller is enabled.

15. Exit the System Setup program and reboot the system.

16. Install any software required for the hard drive operation as described in the documentation for the hard drive.

Removing A 3.5 Inch Hard Drive From The Hard-Drive Bay

 **CAUTION:** Many repairs may only be done by a certified service technician. You should only perform troubleshooting and simple repairs as authorized in your product documentation, or as directed by the online or telephone service and support team. Damage due to servicing that is not authorized by Dell is not covered by your warranty. Read and follow the safety instructions that came with the product.

1. Turn off the system, including any attached peripherals, and disconnect the system from the electrical outlet and peripherals.

2. Lay the system on its side, on a flat and stable surface.

3. Open the system.

4. Remove the power and data cables from the hard drive in the hard-drive bay.

5. Press the retention clips inwards and lift the hard drive from the hard-drive bay.

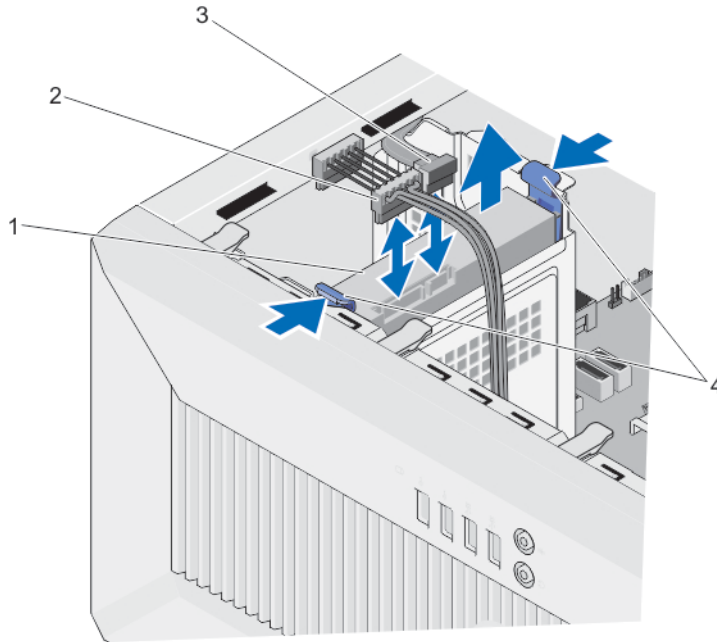

Figure 16. Removing and Installing a 3.5 Inch Hard Drive from the Hard-Drive Bay

1. hard drive
2. hard-drive power cable
3. SATA cable
4. retention clips (2)

Installing A 3.5 Inch Hard Drive In The Hard-Drive Bay

⚠ CAUTION: Many repairs may only be done by a certified service technician. You should only perform troubleshooting and simple repairs as authorized in your product documentation, or as directed by the online or telephone service and support team. Damage due to servicing that is not authorized by Dell is not covered by your warranty. Read and follow the safety instructions that came with the product.

1. Turn off the system, including any attached peripherals, and disconnect the system from the electrical outlet and peripherals.
2. Lay the system on its side, on a flat and stable surface.
3. Open the system.
4. Align the ridges of the hard-drive carrier with the grooves on the hard-drive bay.
5. Insert the hard drive into the hard-drive bay until it clicks into place.
6. Connect the power and data cables to the hard drive.

🔧 NOTE: For information on cabling the hard drives, refer to the System Information Label on the system cover.

🔧 NOTE: SATA cables that connect to the 3.5 inch hard drives in the hard-drive bay should be at a right angle to the hard-drive bay or you will not be able to close the system.

7. Close the system.
8. Place the system upright on a flat, stable surface.
9. Reconnect the system to its electrical outlet and turn the system on, including any attached peripherals.

10. Reboot the system and press <F2> to enter the System Setup and ensure that the hard drive controller is enabled.
11. Exit the System Setup program and reboot the system.
12. Install any software required for the hard drive operation as described in the documentation for the hard drive.

Removing A Hard Drive From A Hard-Drive Carrier

Detach the hard-drive carrier from the hard drive by pushing out at the edges of the carrier and remove the hard drive.

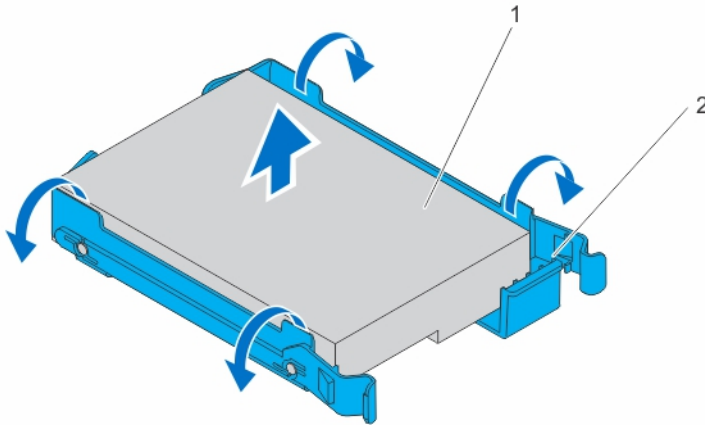

Figure 17. Removing and Installing the Hard Drive From a Hard-Drive Carrier

1. hard drive
2. hard-drive carrier

Installing A Hard Drive Into A Hard-Drive Carrier

1. Align the screw holes on the hard drive with the screws on the hard-drive carrier.
2. Press the hard drive into the hard-drive carrier to secure it.

Optical Drive

Installing The Optical Drive

CAUTION: Many repairs may only be done by a certified service technician. You should only perform troubleshooting and simple repairs as authorized in your product documentation, or as directed by the online or telephone service and support team. Damage due to servicing that is not authorized by Dell is not covered by your warranty. Read and follow the safety instructions that came with the product.

NOTE: Only slim 9.5 mm SATA DVD-ROM drive or DVD+/-RW drive can be installed in your system. External optical drives can be connected through USB ports.

NOTE: If you install an optical drive, you cannot install 2.5 inch hard drives.

NOTE: To install more than four drive devices (including optical drive and hard drives), you need an additional power extension cable, controller card, and SATA cables (minimum 1.6 ft).

 **NOTE:** The screws used to secure the optical drive to the optical drive/hard-drive slot are available on the front of the hard-drive cage.

1. Turn off the system, including any attached peripherals, and disconnect the system from the electrical outlet and peripherals.
2. Lay the system on its side, on a flat and stable surface.
3. Open the system.
4. Remove the bezel.

For more information on removing the bezel, see [Removing The Bezel](#).

5. On the inside of the bezel, press the retention clip and remove the optical-drive blank.

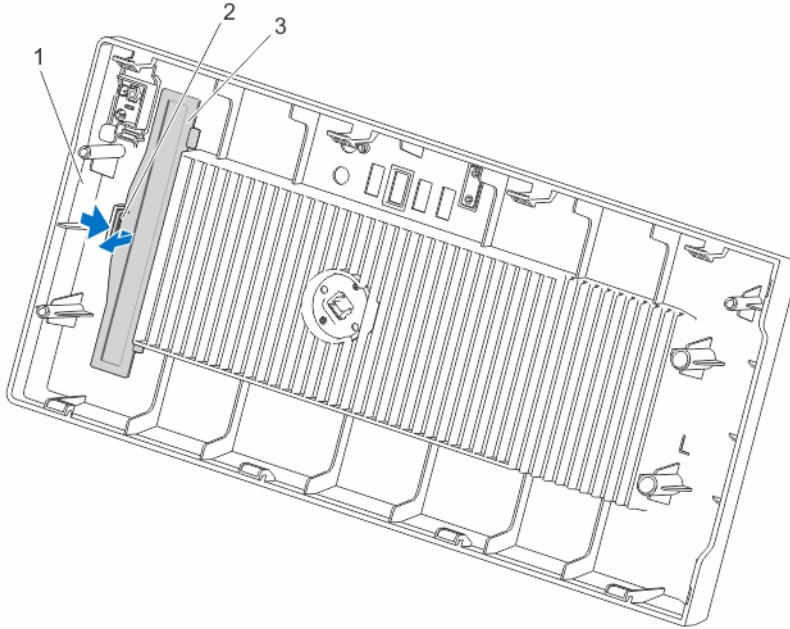

Figure 18. Removing and Installing the Optical-Drive Blank From the Bezel

1. bezel
 2. retention clip
 3. optical-drive blank
6. Remove the hard-drive cage.
For information on removing the hard-drive cage, see [Removing The Hard-Drive Cage](#).
 7. Hold the tabs on the optical-drive filler and remove the optical-drive filler from the hard-drive cage.

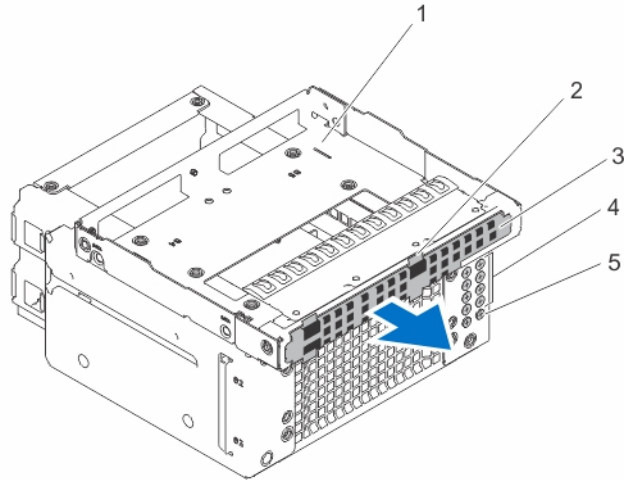

Figure 19. Removing the Optical-Drive Filler

- | | |
|----------------------------------|-----------------------------|
| 1. optical-drive/hard-drive slot | 4. hard-drive screws (8) |
| 2. tabs (4) | 5. optical-drive screws (2) |
| 3. optical-drive filler | |

8. Slide the optical-drive into the optical-drive/hard-drive slot.
9. Tighten the screws on the back of the optical-drive/hard-drive slot to secure the optical drive.

NOTE: The screws used to secure the optical drive to the optical drive/hard-drive slot are available on the front of the hard-drive cage.

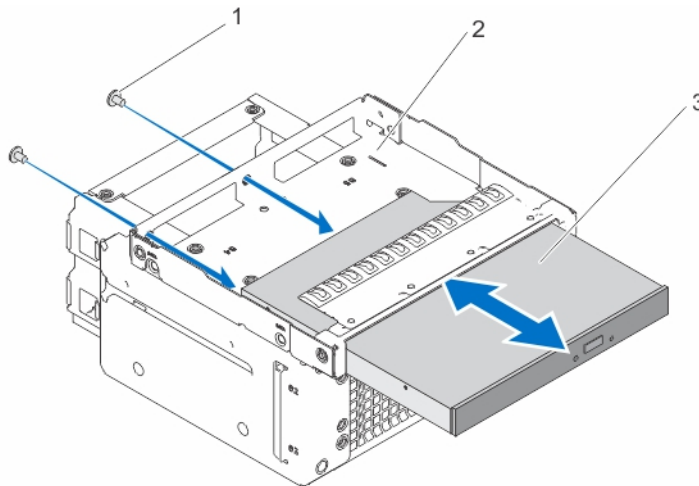



Figure 20. Installing the Optical Drive Into the Optical-Drive/Hard-Drive Slot

- | |
|----------------------------------|
| 1. screws (2) |
| 2. optical-drive/hard-drive slot |
| 3. optical drive |

10. Insert the hard-drive cage into the system.
11. Connect the power and data cables to the optical drive and hard drives, if applicable.

 **NOTE:** Use the vertical type SATA cables to connect hard drives in the hard-drive cage to avoid damaging the connector pins. This is applicable for the 2.5 inch hard drives and optical drive.

12. Install the bezel.
For more information on installing the bezel, see [Installing The Bezel](#).
13. Close the system.
14. Place the system upright on a flat, stable surface.
15. Reconnect the system to its electrical outlet and turn the system on, including any attached peripherals.

Removing The Optical Drive

 **CAUTION:** Many repairs may only be done by a certified service technician. You should only perform troubleshooting and simple repairs as authorized in your product documentation, or as directed by the online or telephone service and support team. Damage due to servicing that is not authorized by Dell is not covered by your warranty. Read and follow the safety instructions that came with the product.

1. Turn off the system, including any attached peripherals, and disconnect the system from the electrical outlet and peripherals.
2. Lay the system on its side, on a flat and stable surface.
3. Open the system.
4. Remove the power and data cables from the optical drive and hard drives, if applicable.
5. Remove the bezel.
For more information on removing the bezel, see [Removing The Bezel](#).
6. Remove the hard-drive cage.
For more information on removing the hard-drive cage, see [Removing The Hard-Drive Cage](#).
7. Remove the screws securing the optical drive to the optical-drive/hard-drive slot.
8. Slide the optical drive out of the optical-drive/hard-drive slot.
9. Install the optical-drive filler into the optical-drive/hard-drive slot.
10. Install the hard-drive cage into the system.
11. If applicable, connect the power and data cables to the hard drives in the hard-drive cage.
12. Install the optical-drive blank into the bezel.
13. Install the bezel.
For more information on installing the bezel, see [Installing The Bezel](#).
14. Close the system.
15. Place the system upright on a flat, stable surface.
16. Reconnect the system to its electrical outlet and turn the system on, including any attached peripherals.

System Memory

Your system supports DDR3 unbuffered ECC DIMMs (ECC UDIMMs). It supports DDR3 and DDR3L voltage specifications.

 **NOTE:** MT/s indicates DIMM speed in MegaTransfers per second.

Memory bus operating frequency can be 1600 MT/s and 1333 MT/s depending on:

- DIMM type (UDIMM)
- DIMM configuration (number of ranks)
- Maximum frequency of the DIMMs
- Number of DIMMs populated per channel

- DIMM operating voltage
- Maximum supported DIMM frequency of the processor

The system contains four memory sockets organized into two channels. In each channel, the release levers of the first socket are marked white and the second socket black.

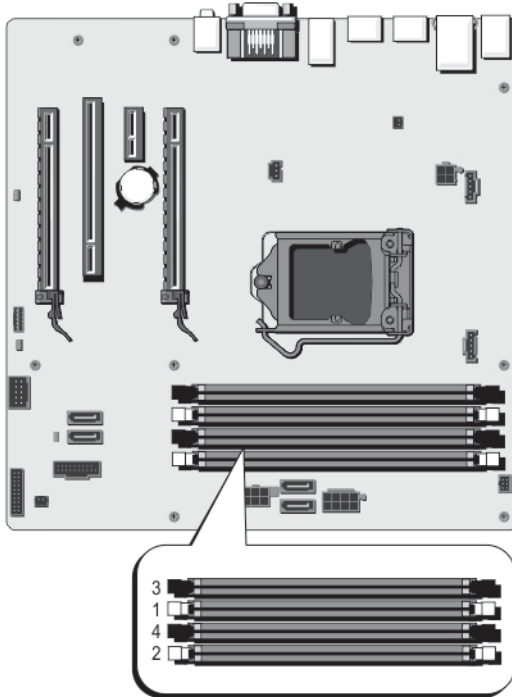

Figure 21. Memory Socket Locations

Memory channels are organized as follows:

- channel A: memory sockets 1 and 3
- channel B: memory sockets 2 and 4

The following table shows the memory populations and operating frequencies for the supported configurations.

DIMM Type	DIMMs Populated/ Channel	Operating Frequency (in MT/s)		Maximum DIMM Rank/ Channel
		1.5 V	1.35 V	
UDIMM ECC	2	1333, 1600	1333, 1600	Dual rank

General Memory Module Installation Guidelines

NOTE: Memory configurations that fail to observe these guidelines can prevent your system from booting, hanging during memory configuration, or operating with reduced memory

NOTE: This system supports only UDIMMs.

The following are the recommended guidelines for best performance:

- A maximum of two UDIMMs can be populated in a channel.

- Populate all sockets with white release tabs first, and then black.
- Populate the sockets by highest rank count in the following order — first in sockets with white release levers, and then black.
- Memory modules of different sizes can be mixed only if other memory population rules are followed.
For example, 2 GB and 4 GB memory modules can be mixed.
- If memory modules with different speeds are installed, they will operate at the speed of the slowest installed memory module(s) or slower depending on system DIMM configuration.

Sample Memory Configurations

The following table shows sample memory configurations for a single processor configuration that follow the appropriate memory guidelines stated in this section.



NOTE: 16 GB quad-rank RDIMMs are not supported.



NOTE: Minimum supported memory is 2 GB and maximum supported memory is 32 GB.



NOTE: 1R and 2R in the following tables indicate single- and dual-rank DIMMs respectively.

Table 11. Memory Configurations

System Capacity (in GB)	DIMM Size (in GB)	Number of DIMMs	DIMM Rank, Organization, and Frequency	DIMM Slot Population
2	2	1	1R, x8, 1333 MT/s, 1 1R, x8, 1600 MT/s	1
4	2	2	1R, x8, 1333 MT/s, 1R, x8, 1600 MT/s	1, 2
8	2	4	1R, x8, 1333 MT/s, 1R, x8, 1600 MT/s	1, 2, 3, 4
16	4	4	2R, x8, 1333 MT/s, 2R, x8, 1600 MT/s	1, 2, 3, 4
32	8	4	2R, x4, 1333 MT/s, 2R, x4, 1600 MT/s	1, 2, 3, 4

Removing Memory Modules



WARNING: The memory modules are hot to the touch for some time after the system has been powered down. Allow time for the memory modules to cool before handling them. Handle the memory modules by the card edges and avoid touching the components or metallic contacts on the memory module.

CAUTION: Many repairs may only be done by a certified service technician. You should only perform troubleshooting and simple repairs as authorized in your product documentation, or as directed by the online or telephone service and support team. Damage due to servicing that is not authorized by Dell is not covered by your warranty. Read and follow the safety instructions that came with the product.

1. Turn off the system, including any attached peripherals, and disconnect the system from the electrical outlet and peripherals.
2. Lay the system on its side, on a flat and stable surface.
3. Open the system.
4. Locate the appropriate memory module socket(s).

CAUTION: Handle each memory module only by the card edges, making sure not to touch the middle of the memory module or gold contacts.

5. Press down and out on the ejectors on each end of the socket until the memory module pops out of the socket.

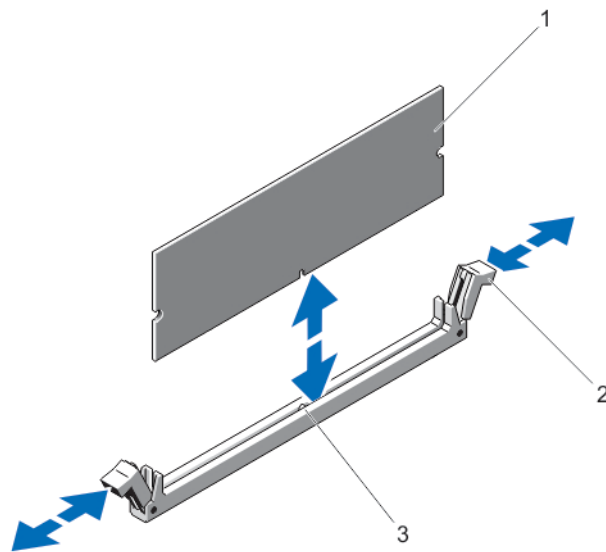



Figure 22. Removing and Installing a Memory Module

1. memory module
2. memory-module socket ejectors (2)
3. alignment key

6. Close the system.
7. Place the system upright on a flat, stable surface.
8. Reconnect the system to its electrical outlet and turn the system on, including any attached peripherals.

Installing Memory Modules

WARNING: The memory modules are hot to the touch for some time after the system has been powered down. Allow time for the memory modules to cool before handling them. Handle the memory modules by the card edges and avoid touching the components or metallic contacts on the memory module.

 **CAUTION:** Many repairs may only be done by a certified service technician. You should only perform troubleshooting and simple repairs as authorized in your product documentation, or as directed by the online or telephone service and support team. Damage due to servicing that is not authorized by Dell is not covered by your warranty. Read and follow the safety instructions that came with the product.

1. Turn off the system, including any attached peripherals, and disconnect the system from the electrical outlet and peripherals.
2. Lay the system on its side, on a flat and stable surface.
3. Open the system.
4. Locate the memory-module socket(s).
5. Press the ejectors on the memory module socket down and out to allow the memory module to be inserted into the socket.

 **CAUTION:** Handle each memory module only by the card edges, making sure not to touch the middle of the memory module or gold contacts.

6. Align the memory module's edge connector with the alignment key of the memory module socket, and insert the memory module in the socket.

 **NOTE:** The memory module socket has an alignment key that allows you to install the memory module in the socket in only one way.

7. Press down on the memory module with your thumbs until the socket levers latch into a locked position. When the memory module is properly seated in the socket, the levers on the memory module socket align with the levers on the other sockets that have memory modules installed.
8. Repeat step 5 through step 7 of this procedure to install the remaining memory modules.
9. Close the system.
10. Place the system upright on a flat, stable surface.
11. Reconnect the system to its electrical outlet and turn the system on, including any attached peripherals.
12. Press <F2> to enter the System Setup, and check the memory settings. The system should have already changed the value to reflect the newly installed memory.
13. If the value is incorrect, one or more of the memory modules may not be installed properly. Repeat step 5 through step 7 of this procedure, checking to ensure that the memory modules are firmly seated in their sockets.
14. Run the appropriate diagnostic test. For more information, see [Using System Diagnostics](#).

System Fan

Your system supports one system fan.

Removing The System Fan

 **CAUTION:** Many repairs may only be done by a certified service technician. You should only perform troubleshooting and simple repairs as authorized in your product documentation, or as directed by the online or telephone service and support team. Damage due to servicing that is not authorized by Dell is not covered by your warranty. Read and follow the safety instructions that came with the product.

 **CAUTION:** Never operate your system with the system fan removed. System can overheat and result in shutdown of the system and loss of data.

⚠ CAUTION: Do not operate the system with the cover removed for a duration exceeding 5 minutes.

1. Turn off the system, including any attached peripherals, and disconnect the system from the electrical outlet and peripherals.
2. Lay the system on its side, on a flat and stable surface.
3. Open the system.
4. Disconnect the system fan power cable from the system board.

⚠ CAUTION: Do not remove or install the system fan by holding the blades.

5. Stretch the grommets securing the fan to the chassis to ease the removal of the fan.
6. Hold the system fan by the sides, slide it out.
7. Repeat steps 5 and 6 to release all four sides of the system fan.

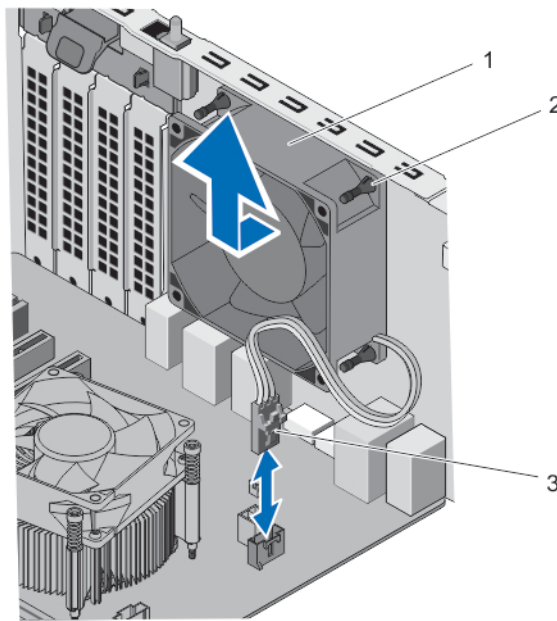

Figure 23. Removing and Installing the System Fan

1. system fan
2. grommets (4)
3. system fan power cable

Installing The System Fan

⚠ CAUTION: Many repairs may only be done by a certified service technician. You should only perform troubleshooting and simple repairs as authorized in your product documentation, or as directed by the online or telephone service and support team. Damage due to servicing that is not authorized by Dell is not covered by your warranty. Read and follow the safety instructions that came with the product.

 **CAUTION: Do not operate the system with the cover removed for a duration exceeding 5 minutes.**

1. Turn off the system, including any attached peripherals, and disconnect the system from the electrical outlet and peripherals.
2. Lay the system on its side, on a flat and stable surface.
3. Hold the system fan by the sides with the cable end facing the bottom of the chassis.
4. Align the four grommets of the system fan with the four grooves on the sides of the system fan.
5. Pass the grommets through the corresponding grooves on the system fan.
6. Stretch the grommets and slide the system fan towards the chassis till it locks into place.

 **NOTE:** Install the lower two grommets first.

 **CAUTION: Do not remove or install the system fan by holding the blades.**

7. Connect the system fan power cable to the system fan connector on the system board.
8. Close the system.
9. Place the system upright on a flat, stable surface.
10. Reconnect the system to its electrical outlet and turn the system on, including any attached peripherals.

Expansion Cards

Expansion Card Installation Guidelines

Table 12. Supported PCI Express Expansion Cards

Expansion Card Slot	Processor Connection	Height	Length	Link Width	Slot Width
1	Processor	Full Height	Half Length	x16	x16
2	Platform Controller Hub (PCH)	Full Height	Half Length	x1	x1
4	Platform Controller Hub (PCH)	Full Height	Half Length	x4	x16

 **NOTE:** Only slot 1 supports Generation 2 and 3 PCIe expansion cards. Slots 2 and 4 support Generation 2 PCIe expansion cards.

 **NOTE:** The expansion cards are not hot-swappable.

 **NOTE:** The power consumption of the PCIe expansion cards is less than 25 W.

Removing An Expansion Card

 **CAUTION: Many repairs may only be done by a certified service technician. You should only perform troubleshooting and simple repairs as authorized in your product documentation, or as directed by the online or telephone service and support team. Damage due to servicing that is not authorized by Dell is not covered by your warranty. Read and follow the safety instructions that came with the product.**

1. Turn off the system, including any attached peripherals, and disconnect the system from the electrical outlet and peripherals.
2. Lay the system on its side, on a flat and stable surface.

3. Open the system.
4. Disconnect all the cables from the expansion card.
5. Holding the card by its edge, pull the card to disengage from the connector and lift the card out of the chassis.
If you are removing the card permanently, install a filler bracket in the empty card slot.

 **NOTE:** Filler brackets must be installed over empty expansion-card slots to maintain FCC certification of the system. The brackets also keep dust and dirt out of the system and aid in proper cooling and airflow inside the system.

6. Push the expansion card latch toward the system until it clicks into place.
7. Close the system.
8. Place the system upright on a flat, stable surface.
9. Reconnect the system to its electrical outlet and turn the system on, including any attached peripherals.

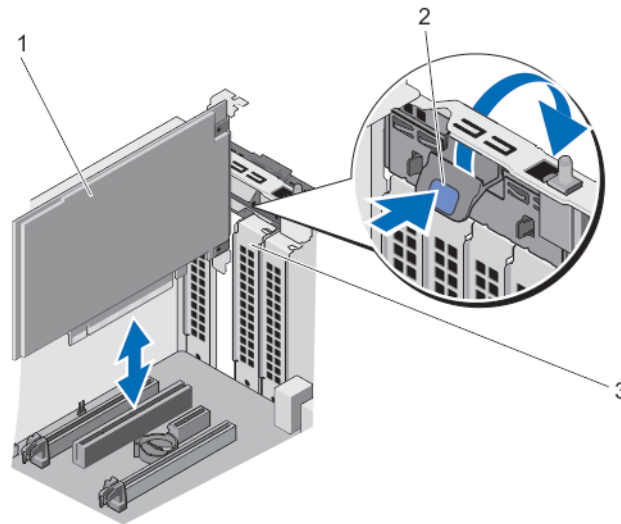



Figure 24. Removing and Installing an Expansion Card

1. expansion card
2. expansion-card latch
3. filler bracket

Installing An Expansion Card

 **CAUTION:** Many repairs may only be done by a certified service technician. You should only perform troubleshooting and simple repairs as authorized in your product documentation, or as directed by the online or telephone service and support team. Damage due to servicing that is not authorized by Dell is not covered by your warranty. Read and follow the safety instructions that came with the product.

1. Unpack the expansion card and prepare it for installation.
For instructions, see the documentation accompanying the card.
2. Turn off the system, including any attached peripherals, and disconnect the system from the electrical outlet and peripherals.
3. Lay the system on its side, on a flat and stable surface.
4. Open the system.

5. Press and push out the expansion card release latch to open it.
Remove the filler bracket, if you are installing a new expansion card.
 **NOTE:** Keep the filler bracket in case you need to remove the expansion card. Filler brackets must be installed over empty expansion-card slots to maintain FCC certification of the system. The brackets also keep dust and dirt out of the system and aid in proper cooling and airflow inside the system.
6. Holding the card by its edges, position the card so that the card-edge connector aligns with the expansion card connector.
7. Insert the card-edge connector into the expansion card connector until the card is fully seated.
8. Push the expansion card latch toward the system until it clicks into place.
9. Close the system.
10. Place the system upright on a flat, stable surface.
11. Reconnect the system to its electrical outlet and turn the system on, including any attached peripherals.

Processors

Your system supports one of the following processors:

- One Intel Xeon processor E3-1225v3
- One Intel Pentium processor G3220

Use the procedures in this section to replace or upgrade your processor.

Removing The Processor

 **CAUTION:** Many repairs may only be done by a certified service technician. You should only perform troubleshooting and simple repairs as authorized in your product documentation, or as directed by the online or telephone service and support team. Damage due to servicing that is not authorized by Dell is not covered by your warranty. Read and follow the safety instructions that came with the product.

 **NOTE:** If you are upgrading your system, download the latest system BIOS version from dell.com/support and follow the instructions included in the compressed download file to install the update on your system.

1. Turn off the system, including any attached peripherals, and disconnect the system from the electrical outlet and peripherals.
2. Lay the system on its side, on a flat and stable surface.
3. Open the system.

 **WARNING:** The heat sink and processor are hot to the touch for some time after the system has been powered down. Allow the heat sink and processor to cool before handling them.

 **CAUTION:** Never remove the heat sink from a processor unless you intend to remove the processor. The heat sink is necessary to maintain proper thermal conditions.

 **NOTE:** Do not remove the processor shield retention screw.

4. Disconnect the processor fan cable from the system board.
5. Using a screwdriver, loosen one captive screw that secures the heat sink to the system board.
6. Wait 30 seconds for the heat sink to loosen from the processor and loosen the screw diagonally opposite the screw removed in the previous step.
7. Repeat steps 6 and 7 for the other pair of screws.
8. Lift the heat sink up from the processor and set it aside upside down (thermal grease side facing up).

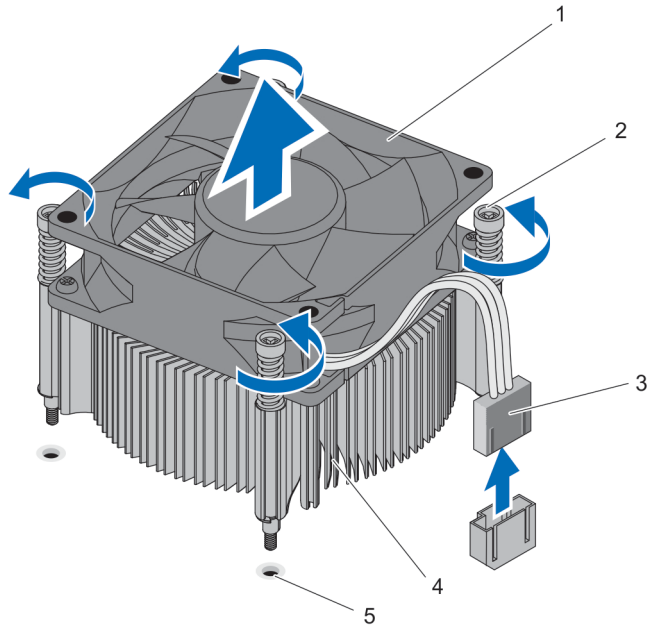

Figure 25. Removing and Installing the Heat-Sink Assembly

- | | |
|------------------------|----------------------|
| 1. processor fan | 4. heat sink |
| 2. captive screws (4) | 5. screw sockets (4) |
| 3. processor fan cable | |

⚠ CAUTION: The processor is held in its socket under strong pressure. Be aware that the release lever can spring up suddenly if not firmly grasped.

- Position your thumb firmly over the processor socket-release lever and release the lever from the locked position by pushing down and out from under the tab. Rotate the lever upwards until the processor shield is open.

⚠ CAUTION: The socket pins are fragile and can be permanently damaged. Be careful not to bend the pins in the socket when removing the processor out of the socket.

- Lift the processor out of the socket.

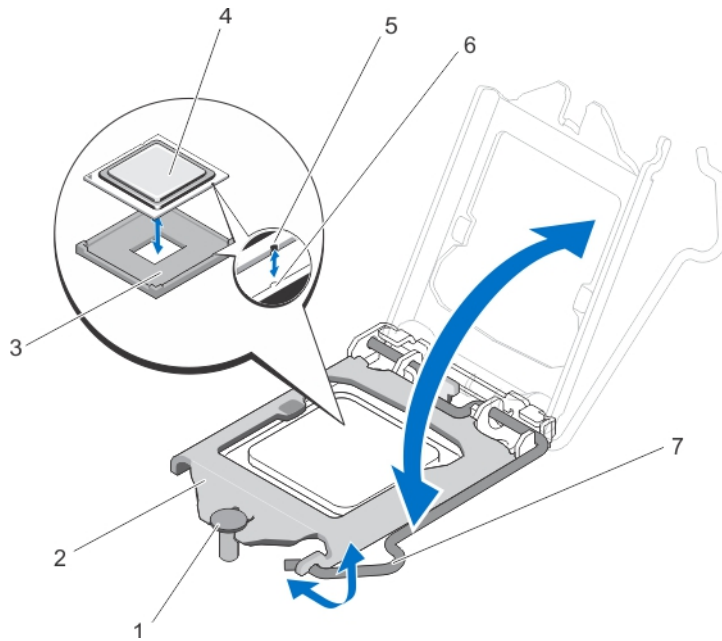

Figure 26. Removing and Installing the Processor

- | | |
|-------------------------------------|-------------------------|
| 1. processor shield retention screw | 5. notch |
| 2. processor | 6. socket keys (2) |
| 3. ZIF socket | 7. socket release lever |
| 4. processor | |

NOTE: After removing the processor, place it in an antistatic container for reuse, return, or temporary storage. Do not touch the bottom of the processor. Touch only the edges of the processor.

Installing The Processor

CAUTION: Many repairs may only be done by a certified service technician. You should only perform troubleshooting and simple repairs as authorized in your product documentation, or as directed by the online or telephone service and support team. Damage due to servicing that is not authorized by Dell is not covered by your warranty. Read and follow the safety instructions that came with the product.

NOTE: If you are upgrading your system, download the latest system BIOS version from dell.com/support and follow the instructions included in the compressed download file to install the update on your system.

1. Turn off the system, including any attached peripherals, and disconnect the system from the electrical outlet and peripherals.
2. Lay the system on its side, on a flat and stable surface.
3. Unpack the new processor.
If the processor has previously been used in a system, remove any remaining thermal grease from the processor using a lint-free cloth.
4. Align the notches on the processor with the socket keys on the ZIF socket.
5. To install the processor in the socket:

 **CAUTION: Positioning the processor incorrectly can permanently damage the system board or the processor. Be careful not to bend the pins in the socket.**

- a) Align the notches on the processor with the socket keys and set the processor lightly in the socket.

 **CAUTION: Do not use force to seat the processor. When the processor is positioned correctly, it engages easily into the socket.**

- b) Close the processor shield by sliding it under the retention screw until it locks into place.
- c) Press the release lever down and then move it inward to secure it with the retention hook.

6. To install the heat sink:

 **CAUTION: Applying too much thermal grease can result in excess grease coming in contact with and contaminating the processor socket.**

- a) Open the grease applicator included with your processor kit and apply all of the thermal grease in the applicator to the center of the topside of the new processor.
- b) Place the heat sink onto the processor.
- c) Align the heat sink screws with the corresponding slots on the system board.
- d) Tighten the four screws to secure the heat sink to the system board.

 **NOTE:** Tighten the screws diagonally opposite to each other. Do not over-tighten the heat sink retention screws when installing the heat sink. To prevent over-tightening, tighten the heat sink retention screw until resistance is felt, and stop once the screw is seated. The screw tension should be no more than 6 in-lb (6.9 kg-cm).

 **NOTE:** Do not remove the processor shield retention screw.

7. Connect the processor fan cable to the system board.
8. Close the system.
9. Place the system upright on a flat, stable surface.
10. Reconnect the system to its electrical outlet and turn the system on, including any attached peripherals.
11. Press <F2> to enter the System Setup and check that the processor information matches the new system configuration.
12. Run the system diagnostics to verify that the new processor operates correctly.

Power Supply

Your system supports 290 W AC power supply.

Removing The Power Supply Unit

 **CAUTION: Many repairs may only be done by a certified service technician. You should only perform troubleshooting and simple repairs as authorized in your product documentation, or as directed by the online or telephone service and support team. Damage due to servicing that is not authorized by Dell is not covered by your warranty. Read and follow the safety instructions that came with the product.**

1. Turn off the system, including any attached peripherals, and disconnect the system from the electrical outlet and peripherals.
2. Lay the system on its side, on a flat and stable surface.
3. Disconnect the power cable from the power supply unit.
4. Open the system.
5. Disconnect the P1 and P2 power cables from the power supply unit to the system board connectors.
6. Remove the screws securing the power supply unit to the chassis.

7. Press the release tab beside the power supply unit, and slide the power supply unit towards the front of the system.
8. Lift the power supply unit out of the system.

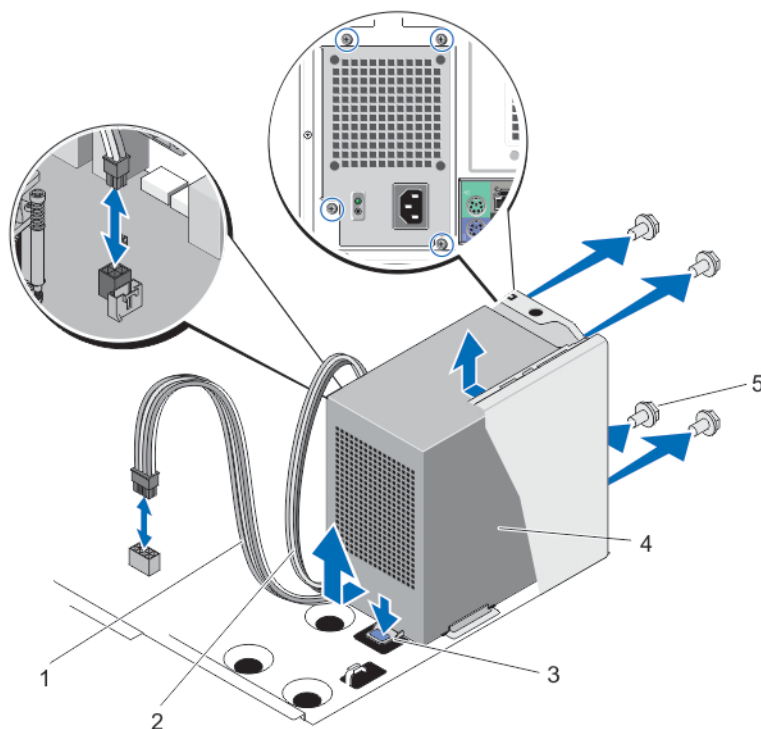

Figure 27. Removing and Installing the Power Supply Unit

- | | |
|-------------------|----------------------|
| 1. P1 power cable | 4. power supply unit |
| 2. P2 power cable | 5. screws (4) |
| 3. release tab | |

Installing The Power Supply Unit

⚠ CAUTION: Many repairs may only be done by a certified service technician. You should only perform troubleshooting and simple repairs as authorized in your product documentation, or as directed by the online or telephone service and support team. Damage due to servicing that is not authorized by Dell is not covered by your warranty. Read and follow the safety instructions that came with the product.

1. Turn off the system, including any attached peripherals, and disconnect the system from the electrical outlet and peripherals.
2. Lay the system on its side, on a flat and stable surface.
3. Unpack the new power supply unit.
4. Open the system.
5. Place the power supply unit in the chassis and slide it towards the back of the chassis.
6. Tighten the screws on the back of the chassis to secure the power supply unit to the chassis.
7. Connect the P1 and P2 power cables to the system board connectors.
8. Close the system.
9. Place the system upright on a flat, stable surface.

10. Reconnect the system to its electrical outlet and turn the system on, including any attached peripherals.

System Battery

Replacing The System Battery

⚠ WARNING: There is a danger of a new battery exploding if it is incorrectly installed. Replace the battery only with the same or equivalent type recommended by the manufacturer. See your safety information for additional information.

⚠ CAUTION: Many repairs may only be done by a certified service technician. You should only perform troubleshooting and simple repairs as authorized in your product documentation, or as directed by the online or telephone service and support team. Damage due to servicing that is not authorized by Dell is not covered by your warranty. Read and follow the safety instructions that came with the product.

1. Turn off the system, including any attached peripherals, and disconnect the system from the electrical outlet and peripherals.
2. Lay the system on its side, on a flat and stable surface.
3. Open the system.
4. Locate the battery socket.

⚠ CAUTION: To avoid damage to the battery connector, you must firmly support the connector while installing or removing a battery.

5. Press the release latch to allow the battery to pop-up from the socket and lift the battery out of the system.

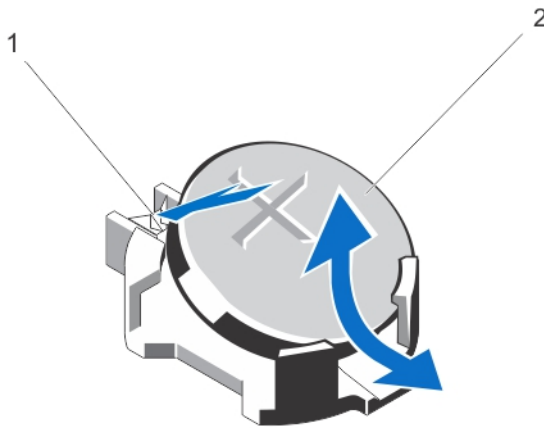



Figure 28. Removing and Installing the System Battery

1. release latch
2. system battery
6. To install a new system battery, hold the battery with the "+" facing up and slide it under the securing tabs at the positive side of the connector.
7. Press the battery straight down into the connector until it snaps into place.
8. Close the system.
9. Place the system upright on a flat, stable surface.

10. Reconnect the system to the electrical outlet and turn the system on, including any attached peripherals.
11. Press <F2> to enter the System Setup to confirm that the battery is operating properly.
12. Enter the correct time and date in the System Setup **Time** and **Date** fields.

System Board

Removing The System Board

 **CAUTION:** Many repairs may only be done by a certified service technician. You should only perform troubleshooting and simple repairs as authorized in your product documentation, or as directed by the online or telephone service and support team. Damage due to servicing that is not authorized by Dell is not covered by your warranty. Read and follow the safety instructions that came with the product.

 **CAUTION:** If you are using the Trusted Program Module (TPM) with an encryption key, you may be prompted to create a recovery key during program or system setup. Be sure to create and safely store this recovery key. If you replace this system board, you must supply the recovery key when you restart your system or program before you can access the encrypted data on your hard drives.

1. Turn off the system, including any attached peripherals, and disconnect the system from the electrical outlet and peripherals.
2. Lay the system on its side, on a flat and stable surface.
3. Open the system.
4. Remove the following:
 - a) system fan
 - b) all expansion cards

 **WARNING:** The heat sink and processor are hot to the touch for some time after the system has been powered down. Allow the heat sink and processor to cool before handling them.

- c) heat sink and processor
 - d) memory modules
5. Disconnect all cables from the system board.
6. Remove the eight screws that secure the system board to the chassis.
7. Hold the system board by the sides and lift it out of the chassis.

 **CAUTION:** Do not lift the system board assembly by grasping a memory module, processor, or other components.

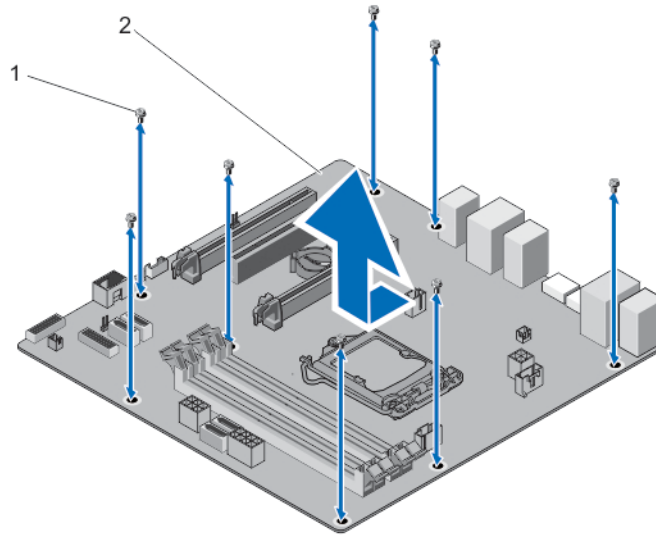

Figure 29. Removing the System Board

1. screws (8)
2. system board

Installing The System Board

CAUTION: Many repairs may only be done by a certified service technician. You should only perform troubleshooting and simple repairs as authorized in your product documentation, or as directed by the online or telephone service and support team. Damage due to servicing that is not authorized by Dell is not covered by your warranty. Read and follow the safety instructions that came with the product.

CAUTION: If you are using the Trusted Program Module (TPM) with an encryption key, you may be prompted to create a recovery key during program or system setup. Be sure to create and safely store this recovery key. If you replace this system board, you must supply the recovery key when you restart your system or program before you can access the encrypted data on your hard drives.

1. Turn off the system, including any attached peripherals, and disconnect the system from the electrical outlet and peripherals.
2. Lay the system on its side, on a flat and stable surface.
3. Unpack the new system board assembly.

CAUTION: Do not lift the system board assembly by grasping any components.

4. Lower the system board into the chassis.
5. Push the system board towards the back of the chassis until the system board clicks into place.
6. Secure the system board to the chassis using the eight screws.

NOTE: It is recommended that you install screws from diagonally opposite corners.

7. Install the following:
 - a) heat-sink assembly and processor
 - b) memory modules
 - c) expansion cards
 - d) system fan

For more installation information, see [Installing System Components](#).

8. Reconnect all cables to the system board.
9. Close the system.
10. Place the system upright on a flat, stable surface.
11. Reconnect the system to its electrical outlet and turn the system on, including any attached peripherals.

Enter the system service tag after you replace the system board. For information on entering the service tag, see [Entering The Service Tag After Replacing The System Board](#).

Entering The Service Tag After Replacing The System Board

Enter the system service tag after you replace the system board.

 **NOTE:** To replace the system board within the warranty period, contact Dell for technical support. To replace the system board after the system warranty expires, see [Removing The System Board](#).

1. Power on the system.
2. Press <F2> to enter the System Setup.
3. Select **Maintenance** → **Service Tag**.
4. Enter the service tag.

 **NOTE:** You can enter the service tag only when the **Service Tag** field is empty. Ensure that you enter the correct service tag. Once the service tag is entered, it cannot be updated or changed.

5. Click **Apply** and **Exit**.

Troubleshooting Your System

Safety First—For You And Your System

 **CAUTION:** Many repairs may only be done by a certified service technician. You should only perform troubleshooting and simple repairs as authorized in your product documentation, or as directed by the online or telephone service and support team. Damage due to servicing that is not authorized by Dell is not covered by your warranty. Read and follow the safety instructions that came with the product.

Power LED Diagnostics

The power button LED located on the front of the chassis also functions as a bicolored diagnostic LED. The diagnostic LED is only active and visible during the Power On Self Test (POST) process. Once the operating system starts to load, it is no longer visible.

Amber LED blinking scheme – The pattern is 2 or 3 blinks followed by a short pause then x number of blinks up to 7. The repeated pattern has a long pause inserted in the middle. For example, 2, 3 = 2 amber blinks, short pause, 3 amber blinks followed by long pause then repeats.

Table 13. Power LED Diagnostics

Amber LED State	White LED State	Description
off	off	system is off
off	blinking	system is in sleep state
blinking	off	power supply unit (PSU) failure
steady	off	PSU is working but failed to fetch code
off	steady	system is on

Amber LED State	Description
2,1	system board failure
2,2	system board, PSU, or PSU cabling failure
2,3	system board, memory, or processor failure
2,4	coin-cell battery failure
2,5	corrupt BIOS
2,6	processor configuration failure or processor failure
2,7	memory modules are detected, but a memory failure
3,1	possible peripheral card or system board failure
3,2	possible USB failure

Amber LED State	Description
3,3	no memory modules are detected
3,4	possible system board error
3,5	memory modules are detected, but a memory configuration or compatibility error
3,6	possible system board resource and/or hardware failure
3,7	some other failure with messages on screen

Memory Beep Code

The system emits a series of beeps during startup if it detects no memory. The beep code pattern emitted is 1-3-2 (1 beep, then 3 beeps, then 2 beeps). The delay between each beep is 300 ms, the delay between each set of beeps is 3 secs, and the beep sound lasts 300 ms. Reseating the memory modules may fix the memory errors. After emitting beeps, the BIOS will detect if the user presses the power button and will execute the normal shutdown process and power the system off.

Troubleshooting System Startup Failure

If you boot the system to the BIOS boot mode after installing an operating system from the UEFI boot mode, the system hangs. The reverse is also true. You must boot to the same boot mode in which you installed the operating system.

For all other startup issues, note the system messages that appear on the screen.

Troubleshooting External Connections

Ensure that all external cables are securely attached to the external connectors on your system before troubleshooting any external devices.

Troubleshooting The Video Subsystem

1. Check the system and power connections to the monitor.
2. Check the video interface cabling from the system to the monitor.
3. Run the appropriate diagnostic test.

If the tests run successfully, the problem is not related to video hardware.

If the tests fail, see [Getting Help](#).

Troubleshooting A USB Device

Use the following steps to troubleshoot a USB keyboard/mouse. For other USB devices, go to step 7.

1. Disconnect the keyboard and mouse cables from the system briefly and reconnect them.
2. Connect the keyboard/mouse to the USB port(s) on the opposite side of the system.
3. If the problem is resolved, restart the system, enter the System Setup, and check if the non-functioning USB ports are enabled.
4. Replace the keyboard/mouse with another working keyboard/mouse.
5. If the problem is resolved, replace the faulty keyboard/mouse.

6. If the problem is not resolved, proceed to the next step to begin troubleshooting the other USB devices attached to the system.
7. Power down all attached USB devices and disconnect them from the system.
8. Reboot the system and, if your keyboard is functioning, enter the System Setup. Verify that all USB ports are enabled on the **Integrated Devices** screen, in the System Setup options.
If your keyboard is not functioning, you can also use remote access. If the system is not accessible, reset the NVRAM_CLR jumper inside your system and restore the BIOS to the default settings.
9. Reconnect and power on each USB device one at a time.
10. If a device causes the same problem, power down the device, replace the USB cable with a known good cable, and power up the device.

If all troubleshooting fails, see [Getting Help](#).

Troubleshooting A Serial I/O Device

1. Turn off the system and any peripheral devices connected to the serial port.
2. Swap the serial interface cable with a working cable, and turn on the system and the serial device.
If the problem is resolved, replace the interface cable with a known good cable.
3. Turn off the system and the serial device, and swap the device with a comparable device.
4. Turn on the system and the serial device.

If the problem persists, see [Getting Help](#).

Troubleshooting A NIC

1. Run the appropriate diagnostic test. See [Using System Diagnostics](#) for available diagnostic tests.
2. Restart the system and check for any system messages pertaining to the NIC controller.
3. Check the appropriate indicator on the NIC connector:
 - If the link indicator does not light, check all cable connections.
 - If the activity indicator does not light, the network driver files might be damaged or missing. Remove and reinstall the drivers if applicable. See the NIC documentation.
 - If applicable, change the autonegotiation setting.
 - Use another connector on the switch or hub.
4. Ensure that the appropriate drivers are installed and the protocols are bound. See the NIC documentation.
5. Enter the System Setup and confirm that the NIC ports are enabled on the **Integrated Devices** screen.
6. Ensure that the NICs, hubs, and switches on the network are all set to the same data transmission speed and duplex. See the documentation for each network device.
7. Ensure that all network cables are of the proper type and do not exceed the maximum length.

If all troubleshooting fails, see [Getting Help](#).

Troubleshooting A Wet System

 **CAUTION:** Many repairs may only be done by a certified service technician. You should only perform troubleshooting and simple repairs as authorized in your product documentation, or as directed by the online or telephone service and support team. Damage due to servicing that is not authorized by Dell is not covered by your warranty. Read and follow the safety instructions that came with the product.

1. Turn off the system and attached peripherals, and disconnect the system from the electrical outlet.
2. Open the system.
3. Disassemble the following components from the system:
 - Hard drives
 - Expansion cards
 - Power supply
 - System fan
 - Processor and heat sink
 - Memory modules
4. Let the system dry thoroughly for at least 24 hours.
5. Reinstall the components you removed in step 3.
6. Close the system.
7. Turn on the system and attached peripherals.
If the system does not start properly, see [Getting Help](#).
8. Run the appropriate diagnostic test. For more information, see [Using System Diagnostics](#).

If the tests fail, see [Getting Help](#).

Troubleshooting A Damaged System

 **CAUTION:** Many repairs may only be done by a certified service technician. You should only perform troubleshooting and simple repairs as authorized in your product documentation, or as directed by the online or telephone service and support team. Damage due to servicing that is not authorized by Dell is not covered by your warranty. Read and follow the safety instructions that came with the product.

1. Turn off the system and attached peripherals, and disconnect the system from the electrical outlet.
2. Open the system.
3. Ensure that the following components are properly installed:
 - Expansion cards
 - Power supply
 - System fan
 - Processor and heat sink
 - Memory modules
4. Ensure that all cables are properly connected.
5. Close the system.
6. Run the appropriate diagnostic test. For more information, see [Using System Diagnostics](#).

If the tests fail, see [Getting Help](#).

Troubleshooting The System Battery

 **CAUTION:** Many repairs may only be done by a certified service technician. You should only perform troubleshooting and simple repairs as authorized in your product documentation, or as directed by the online or telephone service and support team. Damage due to servicing that is not authorized by Dell is not covered by your warranty. Read and follow the safety instructions that came with the product.

 **NOTE:** If the system is turned off for long periods of time (for weeks or months), the NVRAM may lose its system configuration information. This situation is caused by a defective battery.

1. Re-enter the time and date in the System Setup.
2. Turn off the system and disconnect it from the electrical outlet for at least one hour.
3. Reconnect the system to the electrical outlet and turn on the system.
4. Enter the System Setup.
If the date and time are not correct in the System Setup, check the SEL for system battery messages.

If the problem is not resolved, see [Getting Help](#).

 **NOTE:** Some software may cause the system time to speed up or slow down. If the system seems to operate normally except for the time kept in the System Setup, the problem may be caused by software rather than by a defective battery.

Troubleshooting A Non-Redundant Power Supply

 **CAUTION:** Many repairs may only be done by a certified service technician. You should only perform troubleshooting and simple repairs as authorized in your product documentation, or as directed by the online or telephone service and support team. Damage due to servicing that is not authorized by Dell is not covered by your warranty. Read and follow the safety instructions that came with the product.

1. Press the self-diagnostic button on the power supply.
2. If the power supply status indicator is not lit, turn off the system and attached peripherals, and disconnect the system from the electrical outlet.
3. Open the system.
4. Reseat the power supply and the cables.
5. Close the system.
6. If the problem persists, see [Getting Help](#).

Troubleshooting Cooling Problems

 **CAUTION:** Many repairs may only be done by a certified service technician. You should only perform troubleshooting and simple repairs as authorized in your product documentation, or as directed by the online or telephone service and support team. Damage due to servicing that is not authorized by Dell is not covered by your warranty. Read and follow the safety instructions that came with the product.

Ensure that none of the following conditions exist:

- System cover, cooling shroud, EMI filler panel, memory-module blank, or back-filler bracket is removed.
- Ambient temperature is too high.
- External airflow is obstructed.

- A cooling fan is removed or has failed.
- The expansion card installation guidelines have not been followed.

Troubleshooting The System Fan

 **CAUTION:** Many repairs may only be done by a certified service technician. You should only perform troubleshooting and simple repairs as authorized in your product documentation, or as directed by the online or telephone service and support team. Damage due to servicing that is not authorized by Dell is not covered by your warranty. Read and follow the safety instructions that came with the product.

1. Open the system.
2. Reseat the fan or the fan's power cable.
3. If the fan functions properly, close the system.

If the problem persists, see [Getting Help](#).

Troubleshooting System Memory

 **CAUTION:** Many repairs may only be done by a certified service technician. You should only perform troubleshooting and simple repairs as authorized in your product documentation, or as directed by the online or telephone service and support team. Damage due to servicing that is not authorized by Dell is not covered by your warranty. Read and follow the safety instructions that came with the product.

1. If the system is operational, run the appropriate diagnostic test. See [Using System Diagnostics](#) for available diagnostic tests.
If diagnostics indicates a fault, follow the corrective actions provided by the diagnostic program.
2. If the system is not operational, turn off the system and attached peripherals, and unplug the system from the power source. Wait at least 10 seconds and then reconnect the system to power.
3. Turn on the system and attached peripherals and note the messages on the screen.
If an error message is displayed indicating a fault with a specific memory module, go to step 12.
4. Enter the System Setup and check the system memory setting. Make any changes to the memory settings, if needed.
If the memory settings match the installed memory but a problem is still indicated, go to step 12.
5. Turn off the system and attached peripherals, and disconnect the system from the electrical outlet.
6. Open the system.
7. Check the memory channels and ensure that they are populated correctly.
8. Reseat the memory modules in their sockets.
9. Close the system.
10. Enter the System Setup and check the system memory setting.
If the problem is not resolved, proceed with the next step.
11. Open the system.
12. If a diagnostic test or error message indicates a specific memory module as faulty, swap or replace the module with a known good memory module.
13. To troubleshoot an unspecified faulty memory module, replace the memory module in the first DIMM socket with a module of the same type and capacity.
If an error message is displayed on the screen, this may indicate a problem with the installed DIMM type(s), incorrect DIMM installation, or defective DIMM(s). Follow the on-screen instructions to resolve the problem. For more information, see [General Memory Module Installation Guidelines](#).

14. Close the system.
15. As the system boots, observe any error message that is displayed and the diagnostic indicators on the front of the system.
16. If the memory problem is still indicated, repeat step 12 through step 15 for each memory module installed.

If the problem persists after all memory modules have been checked, see [Getting Help](#).

Troubleshooting An Optical Drive

 **CAUTION: Many repairs may only be done by a certified service technician. You should only perform troubleshooting and simple repairs as authorized in your product documentation, or as directed by the online or telephone service and support team. Damage due to servicing that is not authorized by Dell is not covered by your warranty. Read and follow the safety instructions that came with the product.**

1. Try using a different CD or DVD.
2. Enter the System Setup and ensure that the integrated SATA controller and the drive's SATA port are enabled.
3. Run the appropriate diagnostic test.
4. Turn off the system and attached peripherals, and disconnect the system from the electrical outlet.
5. Open the system.
6. Remove the front bezel.
7. Ensure that the interface cable is securely connected to the drive and to the controller.
8. Ensure that a power cable is properly connected to the drive.
9. Close the system.

If the problem is not resolved, see [Getting Help](#).

Troubleshooting A Hard Drive

 **CAUTION: Many repairs may only be done by a certified service technician. You should only perform troubleshooting and simple repairs as authorized in your product documentation, or as directed by the online or telephone service and support team. Damage due to servicing that is not authorized by Dell is not covered by your warranty. Read and follow the safety instructions that came with the product.**

 **CAUTION: This troubleshooting procedure can erase data stored on the hard drive. Before you proceed, back up all files on the hard drive.**

1. Run the appropriate diagnostic test. For more information, see [Using System Diagnostics](#). Depending on the results of the diagnostics test, proceed as needed through the following steps.
2. Ensure that the required device drivers for your controller card are installed and are configured correctly. See the operating system documentation for more information.
3. Restart the system and enter the System Setup.
4. Verify that the controller is enabled and the drives are displayed in the System Setup.

If the problem persists, try troubleshooting the expansion cards or see [Getting Help](#).

Troubleshooting Expansion Cards

 **CAUTION:** Many repairs may only be done by a certified service technician. You should only perform troubleshooting and simple repairs as authorized in your product documentation, or as directed by the online or telephone service and support team. Damage due to servicing that is not authorized by Dell is not covered by your warranty. Read and follow the safety instructions that came with the product.

 **NOTE:** When troubleshooting an expansion card, see the documentation for your operating system and the expansion card.

1. Run the appropriate diagnostic test. For more information, see [Using System Diagnostics](#).
2. Turn off the system and attached peripherals, and disconnect the system from the electrical outlet.
3. Open the system.
4. Ensure that each expansion card is firmly seated in its connector.
5. Close the system.
6. If the problem is not resolved, turn off the system and attached peripherals, and disconnect the system from the electrical outlet.
7. Open the system.
8. Remove all expansion cards installed in the system.
9. Close the system.
10. Run the appropriate diagnostic test. For more information, see [Using System Diagnostics](#).
If the tests fail, see [Getting Help](#).
11. For each expansion card you removed in step 8, perform the following steps:
 - a) Turn off the system and attached peripherals, and disconnect the system from the electrical outlet.
 - b) Open the system.
 - c) Reinstall one of the expansion cards.
 - d) Close the system.
 - e) Run the appropriate diagnostic test. For more information, see [Using System Diagnostics](#).

If a problem is still indicated, see [Getting Help](#).

Troubleshooting The Processor

 **CAUTION:** Many repairs may only be done by a certified service technician. You should only perform troubleshooting and simple repairs as authorized in your product documentation, or as directed by the online or telephone service and support team. Damage due to servicing that is not authorized by Dell is not covered by your warranty. Read and follow the safety instructions that came with the product.

1. Run the appropriate diagnostics test. See [Using System Diagnostics](#) for available diagnostic tests.
2. Turn off the system and attached peripherals, and disconnect the system from the electrical outlet.
3. Open the system.
4. Ensure that the processor and heat sink are properly installed.
5. Close the system.
6. Run the appropriate diagnostic test. For more information, see [Using System Diagnostics](#).

If a problem is still indicated, see [Getting Help](#).

Using System Diagnostics

If you experience a problem with your system, run the system diagnostics before contacting Dell for technical assistance. The purpose of running system diagnostics is to test your system hardware without requiring additional equipment or risking data loss. If you are unable to fix the problem yourself, service and support personnel can use the diagnostics results to help you solve the problem.

Enhanced Pre-Boot System Assessment Diagnostics

The Enhanced Pre-Boot System Assessment (ePSA) diagnostics (also known as system diagnostics) performs a complete check of your hardware. The ePSA is embedded with the BIOS and is launched by the BIOS internally. The embedded system diagnostics provides a set of options for particular device groups or devices allowing you to:

- Run tests automatically or in an interactive mode
- Repeat tests
- Display or save test results
- Run thorough tests to introduce additional test options to provide extra information about the failed device(s)
- View status messages that inform you if tests are completed successfully
- View error messages that inform you of problems encountered during testing



CAUTION: Use the system diagnostics to test only your system. Using this program with other systems may cause invalid results or error messages.



NOTE: Some tests for specific devices require user interaction. Always ensure that you are present at the system terminal when the diagnostic tests are performed.

1. Power-on the system.
2. As the system boots, press the <F12> key as the Dell logo is displayed.
3. On the boot menu screen, select the **Diagnostics** option.
The **Enhanced Pre-boot System Assessment** window is displayed, listing all devices detected in the system. The diagnostics starts running the tests on all the detected devices.
4. If you wish to run a diagnostic test on a specific device, press <Esc> and click **Yes** to stop the diagnostic test.
5. Select the device from the left pane and click **Run Tests**.
6. If there are any issues, error codes are displayed.
Note the error code and contact Dell.

System Diagnostic Controls

Menu	Description
Configuration	Displays the configuration and status information of all detected devices.
Results	Displays the results of all tests that are executed.

Menu	Description
System Health	Provides the current overview of the system performance.
Event Log	Displays a time-stamped log of the results of all tests run on the system. This is displayed if at least one event description is recorded.





For information about embedded system diagnostics, see the *Dell Enhanced Pre-boot System Assessment User Guide* at dell.com/support/manuals.

Jumpers And Connectors

System Board Jumper Settings

For information on resetting the password jumper to disable a password, see [System Board Jumper Settings](#)

Table 14. System Board Jumper Settings

Jumper	Setting	Description
PSWD	 (jumper engaged_ default)	The password feature is enabled.
	 (jumper removed)	Clears BIOS password.
RTCRST	 (jumper removed_ default)	Real-time clock reset. Can be used for troubleshooting (pins 1 and 2).
	 (jumper engaged)	Recovers BIOS setting to default.

System Board Connectors

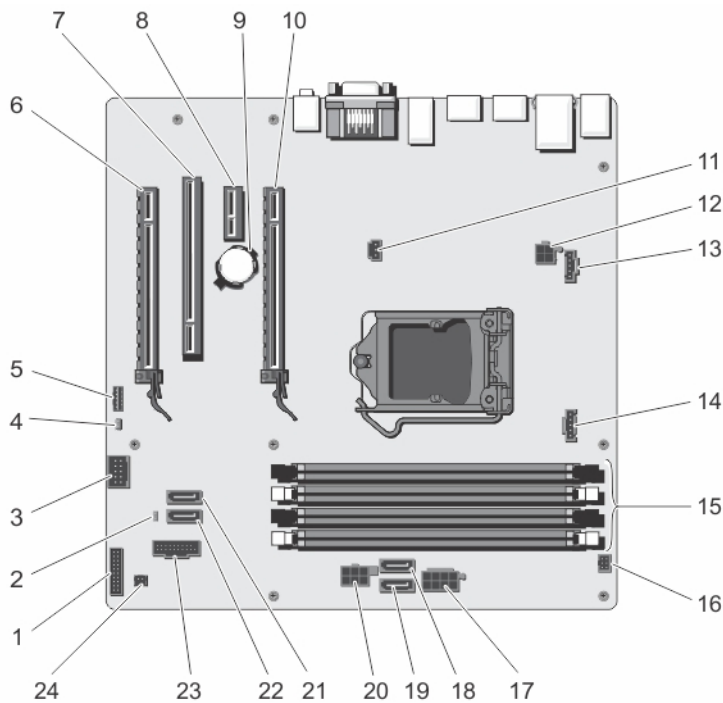

Figure 30. System Board Jumpers and Connectors

Item	Connector	Description
1	FRONTPANEL	Front IO connector
2	PSWD	Password jumper
3	INT_USB	Internal USB connector
4	RTCRST	RTCRST jumper
5	INT_SPKR	Internal speaker
6	SLOT 4	PCIe card connector 4
7	SLOT 3	PCI card connector 3
8	SLOT 2	PCIe card connector 2
9	BATTERY	Battery connector
10	SLOT 1	PCIe card connector 1
11	INTRUDER	Intrusion switch connector
12	12V_PWRCONN	P2 power connector
13	FAN_SYS	System fan connector
14	FAN_CPU	Processor fan connector
15	DDR DIMM memory slots (4)	DIMM slots 1–4
16	PWR_SW	Power switch connector
17	POWER	P1 power connector
18	SATA2	SATA2 connector
19	SATA3	SATA3 connector
20	HDD_ODD_POWER	HDD_ODD power cable connector
21	SATA0	SATA0 connector
22	SATA1	SATA1 connector
23	USB 3_FRONT	Front USB 3.0 connector
24	THRM	Thermal sensor connector

Disabling A Forgotten Password

The system's software security features include a system password and a admin password. The password jumper disables any password(s) currently in use.

1. Open the system.
2. Identify the PSWD jumper on the system board.
3. Remove the PSWD jumper from the system board.



NOTE: The existing passwords are not disabled (erased) until the system boots without the jumper.

4. Install the cover.

 **NOTE:** If you assign a new system and/or admin password with the PSWD jumper installed, the system disables the new password(s) the next time it boots.



5. Connect the system to the electrical outlet and power-on the system.
6. Power off the system and disconnect the power cable from the electrical outlet.
7. Remove the cover.
8. Replace the PSWD jumper on the system board.
9. Close the system.
10. Power on the system.
11. Go to the system setup, and assign a new system or admin password.

For information on assigning a system or admin password, see [Assigning A System And Admin Password](#).

Technical Specifications

Processor	
Processor type	<ul style="list-style-type: none"> • One Intel Xeon processor E3-1225v3, or • One Intel Pentium processor G3220
Expansion Bus	
Bus type	PCI Express Generation 2 and 3
Expansion slots	<p>(Slot 1) One full-height, half-length x16 PCIe Gen3 card slot connected to processor</p> <p>(Slot 2) One full-height, half-length x1 PCIe Gen2 card slot connected to Platform Controller Hub (PCH)</p> <p>(Slot 3) One full-height, half-length PCI 32/33 card slot connected to PCIe and PCI Bridge</p> <p>(Slot 4) One full-height, half-length x16 (x4) PCIe Gen2 card slot connected to PCH</p>
Memory	
Architecture	<p>1333 MT/s or 1600 MT/s DDR3 unbuffered Error Correcting Code (ECC) DIMMs</p> <p>Support for advanced ECC or memory optimized operation</p>
Memory module sockets	Four 240-pin
Memory module capacities	2 GB (single-rank), 4 GB (single- and dual-rank), and 8 GB (dual-rank)
Minimum RAM	2 GB
Maximum RAM	32 GB
Drives	
Hard drives	Up to four 3.5 inch, internal, cabled SATA or SATA SSoD hard drives.
Four hard-drive systems	

Drives

Six hard-drive systems	Up to four 3.5 inch internal, cabled SATA, or SATA SSD drives and one optical disk drive (optional). Two 3.5 inch and two 2.5 inch (optional), internal, cabled SATA, or SATA SSD drives. Up to four 3.5 inch and two 2.5 inch (optional), internal, cabled SATA, or SATA SSD drives.  NOTE: If you install more than four hard drives, you need to get an additional SATA controller card, SATA cables (minimum 1.6 ft) and power extension cables.
Optical drive	Optional slim 9.5 mm SATA DVD-ROM drive or DVD+/-RW drive.  NOTE: External optical drives can be connected through USB ports.

Connectors

Back

NIC	Two 10/100/1000 Mbps
Serial	9-pin, DTE, 16550-compatible
USB	Four 4-pin USB 2.0-compliant Two 4-pin USB 3.0-compliant
Video	Two 15-pin VGA display ports

Front

USB	Two 4-pin USB 2.0-compliant Two 4-pin USB 3.0-compliant
-----	--

Video



Video type	Integrated Intel HD P4600 Graphics  NOTE: This is available only on select Intel Xeon processors.
------------	--

Environmental Specifications

Temperature

Operating	5 °C to 35°C (41 °F to 95 °F)
Storage	–40 °C to 65 °C (–40 °F to 149 °F)

Relative Humidity (maximum)

Operating	20% to 80% (non-condensing)
Storage	5% to 95% (non-condensing)
Maximum Vibration	
Operating	0.26 G _{rms}
Storage	2.20 G _{rms}
Maximum Shock	
Operating	40 G
Storage	105 G
Altitude	
Operating	-15.20 m to 3048 m (-50 ft to 10,000 ft)
	 NOTE: In compliance with the requirements of the official Chinese standards, the operating altitude for systems shipping in China is in the range of -15.2 m to 5000 m (-50 ft to 16400 ft).
	 NOTE: For altitudes above 2950 ft, the maximum operating temperature is derated 1 °F/550 ft.
Storage	-15.20 m to 10,668 m (-50 ft to 35,000 ft)

System Messages

Error Messages

Error Message	Description
Address mark not found	The BIOS found a faulty disk sector or could not find a particular disk sector.
Alert! Previous attempts at booting this system have failed at checkpoint [nnnn]. For help in resolving this problem, please note this checkpoint and contact Dell Technical Support.	The system failed to complete the boot routine three consecutive times for the same error. Contact Dell and report the checkpoint code (nnnn) to the support technician.
Alert! Security override Jumper is installed.	The MFG_MODE jumper has been set and AMT Management features are disabled until it is removed.
Attachment failed to respond	The floppy or hard-drive controller cannot send data to the associated drive.
Bad command or file name	Ensure that you have spelled the command correctly, put spaces in the proper place, and used the correct pathname.
Bad error-correction code (ECC) on disk read	The floppy or hard-drive controller detected an uncorrectable read error.
Controller has failed	The hard drive or the associated controller is defective.
Data error	The floppy or hard drive cannot read the data. For the Windows operating system, run the chkdsk utility to check the file structure of the floppy or hard drive. For any other operating system, run the appropriate corresponding utility.
Decreasing available memory	One or more memory modules may be faulty or improperly seated. Re-install the memory modules and, if necessary, replace them.
Diskette drive 0 seek failure	A cable may be loose or the system configuration information may not match the hardware configuration.
Diskette read failure	The floppy disk may be defective or a cable may be loose. If the drive access light turns on, try a different disk.

Error Message	Description
Diskette subsystem reset failed	The floppy drive controller may be faulty.
Gate A20 failure	One or more memory modules may be faulty or improperly seated. Reinstall the memory modules and, if necessary, replace them.
General failure	The operating system is unable to carry out the command. This message is usually followed by specific information—for example, Printer out of paper . Take the appropriate action to resolve the problem.
Hard-disk drive configuration error	The hard drive failed initialization.
Hard-disk drive controller failure	The hard drive failed initialization.
Hard-disk drive failure	The hard drive failed initialization.
Hard-disk drive read failure	The hard drive failed initialization.
Invalid configuration information-please run SETUP program	The system configuration information does not match the hardware configuration.
Invalid Memory configuration, please populate DIMM1	DIMM1 slot does not recognize a memory module. The module should be re-seated or installed.
Keyboard failure	A cable or connector may be loose, or the keyboard or keyboard/mouse controller may be faulty.
Memory address line failure at address, read value expecting value	A memory module may be faulty or improperly seated. Reinstall the memory modules and, if necessary, replace them.
Memory allocation error	The software you are attempting to run is conflicting with the operating system, another program, or a utility.
Memory data line failure at address, read value expecting value	A memory module may be faulty or improperly seated. Reinstall the memory modules and, if necessary, replace them.
Memory double word logic failure at address, read value expecting value	A memory module may be faulty or improperly seated. Reinstall the memory modules and, if necessary, replace them.
Memory odd/even logic failure at address, read value expecting value	A memory module may be faulty or improperly seated. Reinstall the memory modules and, if necessary, replace them.

Error Message	Description
Memory write/read failure at address, read value expecting value	A memory module may be faulty or improperly seated. Reinstall the memory modules and, if necessary, replace them.
Memory size in CMOS invalid	The amount of memory recorded in the system configuration information does not match the memory installed in the system.
Memory tests terminated by keystroke	A keystroke interrupted the memory test.
No boot device available	The system cannot find the floppy disk or hard drive.
No boot sector on hard-disk drive	The system configuration information in System Setup may be incorrect.
No timer tick interrupt	A chip on the system board might be malfunctioning.
Non-system disk or disk error	The floppy disk in drive A does not have a bootable operating system installed on it. Either replace the floppy disk with one that has a bootable operating system, or remove the floppy disk from drive A and restart the system.
Not a boot diskette	The operating system is trying to boot to a floppy disk that does not have a bootable operating system installed on it. Insert a bootable floppy disk.
Plug and play configuration error	The system encountered a problem while trying to configure one or more cards.
Read fault	The operating system cannot read from the floppy or hard drive, the system could not find a particular sector on the disk, or the requested sector is defective.
Requested sector not found	The operating system cannot read from the floppy or hard drive, the system could not find a particular sector on the disk, or the requested sector is defective.
Reset failed	The disk re-set operation failed.
Sector not found	The operating system cannot locate a sector on the floppy or hard drive.
Seek error	The operating system cannot find a specific track on the floppy disk or hard drive.
Shutdown failure	A chip on the system board might be malfunctioning.
Time-of-day clock stopped	The battery might be dead.
Time-of-day not set-please run the System Setup program	The time or date stored in System Setup does not match the system clock.
Timer chip counter 2 failed	A chip on the system board may be malfunctioning.
Unexpected interrupt in protected mode	The keyboard controller may be malfunctioning or a memory module may be loose.

Error Message	Description
WARNING: Dell's Disk Monitoring System has detected that drive [0/1] on the [primary/secondary] EIDE controller is operating outside of normal specifications. It is advisable to immediately back up your data and replace your hard drive by calling your support desk or Dell.	During initial startup, the drive detected possible error conditions. When your system finishes booting, immediately back up your data and replace your hard drive. For information on installation procedures, see Installing System Components . If no replacement drive is immediately available and the drive is not the only bootable drive, enter System Setup and change the appropriate drive setting to None . Then remove the drive from the system.
Write fault	The operating system cannot write to the floppy or hard drive.
Write fault on selected drive	The operating system cannot write to the floppy or hard drive.

Warning Messages

A warning message alerts you to a possible problem and prompts you to respond before the system continues a task. For example, before you format a hard drive, a message warns you that you may lose all data on the hard drive. Warning messages usually interrupt the task and require you to respond by typing y (yes) or n (no).

 **NOTE:** Warning messages are generated by either the application or the operating system. For more information, see the documentation that accompanied the operating system or application.

Alert Messages

Systems management software generates alert messages for your system. Alert messages include information, status, warning, and failure messages for drive, temperature, fan, and power conditions. For more information, see the systems management software documentation.

Getting Help

Contacting Dell

 **NOTE:** If you do not have an active Internet connection, you can find contact information on your purchase invoice, packing slip, bill, or Dell product catalog.

Dell provides several online and telephone-based support and service options. Availability varies by country and product, and some services may not be available in your area. To contact Dell for sales, technical support, or customer service issues:

1. Go to dell.com/contactdell.
2. Verify your country or region from the drop-down menu at the top left corner of the page.
3. Select your support category: **Technical Support**, **Customer Support**, **Sales**, or **International Support Services**.
4. Select the appropriate service or support link based on your requirement.

 **NOTE:** If you have purchased a Dell system, you may be asked for the Service Tag.

Locating Your System Service Tag

Your system is identified by a unique Express Service Code and Service Tag number. The Express Service Code and Service Tag are found on the front of the system by pulling out the information tag. This information is used by Dell to route support calls to the appropriate personnel.

Documentation Feedback

If you have feedback for this document, write to documentation_feedback@dell.com. Alternatively, you can click on the **Feedback** link in any of the Dell documentation pages, fill out the form, and click **Submit** to send your feedback.